

IOT Based Smart Energy Theft Detection Using Current Imbalance Alerts And Prepaid Billing

Dr. V. Anantha Lakshmi¹, Y. Rajeshwari², G. Indumathi³

Assistant professor, Electrical & Electronics Engineering,

Andhra Loyola institute of engineering & technology, Vijayawada, India¹

Final year student, Electrical & Electronics Engineering,

Andhra Loyola institute of engineering & technology, Vijayawada, India²

Final year student, Electrical & Electronics Engineering,

Andhra Loyola institute of engineering & technology, Vijayawada, India³

Abstract: Electricity theft remains a significant challenge in modern power distribution systems, leading to substantial economic losses, reduced system efficiency, and degraded power quality. Traditional metering systems lack real-time monitoring and fail to detect unauthorized consumption effectively. This paper proposes an Internet of Things (IoT)-based smart energy theft detection system that utilizes the principle of current imbalance combined with a prepaid billing mechanism.

The system employs dual current sensing points at the input and output sides of the energy meter to continuously monitor current flow. Any discrepancy between these values indicates potential theft. The Arduino-based controller processes the sensor data and triggers immediate actions such as visual alerts on an LCD, audible warnings through a buzzer, SMS notifications via a GSM module, and automatic power disconnection using a relay. Additionally, an RFID-based prepaid billing system ensures controlled energy consumption by allowing users to utilize electricity based on available balance.

The proposed system offers a cost-effective, scalable, and efficient solution for real-time monitoring, theft detection, and energy management, making it suitable for residential and small-scale industrial applications.

Keywords: IoT, Energy Theft Detection, Current Imbalance, Arduino, GSM, RFID, Smart Energy Meter, Prepaid Billing.

I. INTRODUCTION

Electricity theft is a major contributor to non-technical losses (NTLs) in power distribution systems, particularly in developing countries. It occurs through unauthorized practices such as meter tampering, direct line tapping, and bypassing energy meters, leading to financial losses, network overloading, and reduced system reliability.

Traditional energy meters are limited to recording cumulative consumption and lack real-time monitoring or theft detection capabilities. Existing detection methods rely on manual inspections, which are inefficient and often unable to identify sophisticated theft techniques.

With advancements in communication technologies, Internet of Things (IoT)-based smart metering systems have emerged as an effective solution. These systems enable real-time monitoring of electrical parameters and remote data access, improving transparency and operational efficiency [1], [2].

Various approaches have been proposed to address electricity theft. Current-based detection techniques identify discrepancies between supply and load currents, offering a simple and cost-effective solution [3]. Prepaid energy metering systems ensure controlled consumption and reduce unpaid usage [4], while machine learning-based methods analyze consumption patterns to detect anomalies [5]. However, these approaches are often implemented independently or require high computational resources.

To overcome these limitations, this paper proposes an integrated system that combines current imbalance-based theft detection, IoT-based real-time monitoring, and prepaid billing with automatic load control. The proposed approach provides a low-cost, scalable, and efficient solution for smart energy management.

II. LITERATURE SURVEY

Electricity theft contributes significantly to non-technical losses in power systems, affecting both economic efficiency and grid reliability. With the evolution of smart grids, IoT-based monitoring and control systems have emerged as practical solutions for real-time detection and management of unauthorized electricity usage.

An IoT-based smart energy metering system using current sensors is presented in [3], where electricity theft is detected by comparing current values at different points in the distribution line. The system employs wireless communication for real-time data transmission and demonstrates that current imbalance detection is a simple and effective method for identifying unauthorized consumption. However, the system lacks an integrated billing mechanism to control user behavior.

In [1], an IoT-enabled smart energy monitoring system is developed to improve transparency and enable remote access to energy consumption data. The system highlights the role of communication technologies in reducing manual intervention and improving operational efficiency. While it provides real-time monitoring and alert generation, it does not incorporate automated control or prepaid billing, limiting its ability to prevent misuse.

A more integrated approach is proposed in [4], where an IoT-based prepaid smart energy meter is designed with theft detection capabilities. The system includes GSM communication, real-time billing, and automatic disconnection when the prepaid balance is exhausted. This enhances revenue protection and user accountability. However, the theft detection mechanism is primarily based on tamper detection rather than continuous current imbalance analysis, which may not detect all forms of unauthorized usage.

Additionally, real-time energy monitoring systems using threshold-based current analysis are discussed in [6]. These systems detect anomalies by comparing measured values with predefined limits and generate alerts through IoT platforms. Although effective in controlled conditions, their performance may degrade under dynamic load variations, leading to potential inaccuracies.

From the above studies, it is evident that:

Current imbalance methods provide real-time and low-cost theft detection

IoT enables remote monitoring and alert systems

Prepaid billing ensures controlled energy usage and revenue security

However, existing systems typically implement these features independently rather than in an integrated manner. This creates a gap in developing a unified system that combines detection, communication, and billing.

Therefore, the proposed system focuses on integrating:

Current imbalance-based theft detection

IoT-based real-time alert mechanism

Prepaid billing with automatic load control

This combination aims to provide a practical, scalable, and cost-effective solution for smart energy management.

III. PROPOSED SYSTEM

3.1 System Design Overview

The proposed system is designed to detect electricity theft using current imbalance analysis and to control energy consumption through a prepaid billing mechanism. It integrates sensing, processing, communication, and control units to ensure real-time monitoring and automated response. The system continuously compares input and load currents, identifies unauthorized usage, and takes immediate action such as alert generation and supply disconnection.

3.2 System Architecture

The system consists of current sensors placed at the supply and load sides to measure current values for comparison. An Arduino microcontroller is used for data processing and decision-making. An RFID module is used for prepaid billing, while a Wi-Fi/GSM module enables communication. A relay module controls the load connection, and an LCD display along with a buzzer provides user interface and alerts.

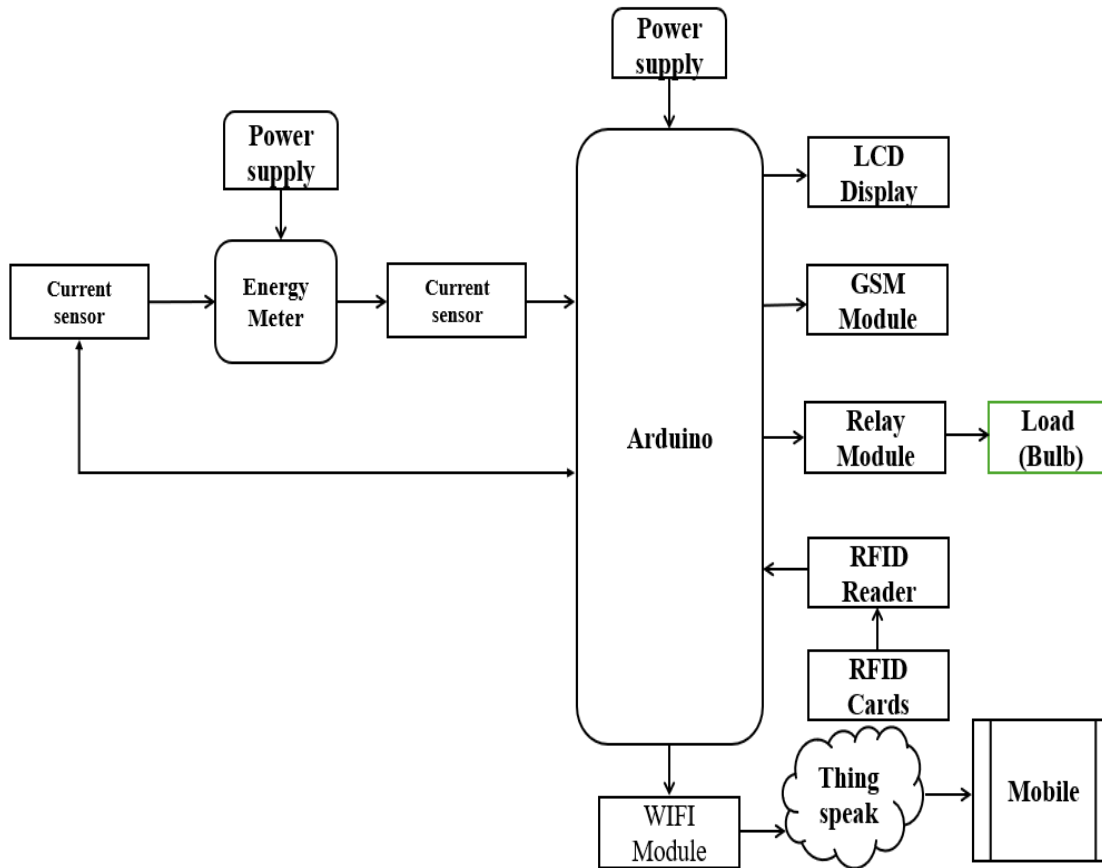

3.2(a) Block Diagram

3.3 Current Imbalance Detection Mechanism

Electricity theft is identified by comparing the current measured before and after the energy meter. Under normal conditions, both values remain approximately equal. Any significant deviation indicates unauthorized tapping. When the input current exceeds the load current beyond a predefined threshold, the system classifies it as a theft condition and triggers alert and control actions.

3.4 Prepaid Billing Mechanism

The prepaid system operates using an RFID-based recharge model. The user is assigned a specific energy balance, which decreases energy consumption. When the balance reaches a minimum threshold, a warning is generated. If the balance becomes zero, the system automatically disconnects the load using a relay, ensuring controlled energy usage and preventing unpaid consumption.

3.5 IoT-Based Monitoring and Communication

The system uses a communication module to transmit real-time data and alerts to the authorized user. Notifications such as theft detection and low balance are sent instantly, enabling remote monitoring and quick response. This improves transparency and reduces the need for manual inspection.

3.6 Control Strategy

The system follows a rule-based control mechanism. In theft conditions, the relay disconnects the supply and an alert is generated. In prepaid mode, the relay operation depends on the available balance. The integration of detection and control ensures both prevention of unauthorized usage and efficient energy management.

IV. IMPLEMENTATION

4.1 Hardware Implementation:

The system is implemented using an Arduino microcontroller as the central processing unit. Two current sensors are placed at the supply side and load side to measure current values for comparison. A voltage sensor is used to monitor the supply voltage. An RFID module is integrated for prepaid billing functionality. A relay module is used to control the load

connection, while an LCD display provides real-time system status. A buzzer is included for local alerts, and a Wi-Fi/GSM module enables communication for remote monitoring.

4.2 Circuit Configuration:

All sensors and modules are interfaced with the microcontroller through appropriate analog and digital pins. The current sensors are connected to analog inputs for continuous monitoring. The communication module is interfaced using serial communication pins. The relay is connected through a digital output pin to control load switching. Proper grounding and power supply connections are ensured for stable operation of all components.

4.3 Software Implementation

The system is programmed using embedded C in the Arduino environment. The software continuously reads sensor data, processes current values, and compares them to detect imbalance conditions. The prepaid balance is updated based on energy consumption, and control decisions are made accordingly. Conditional statements are used to trigger alerts and relay operations based on predefined thresholds.

4.4 Working Procedure:

Initially, the system reads input and load current values under normal conditions. These values are continuously monitored and compared. If a significant difference is detected, the system identifies it as a theft condition and activates the buzzer, sends an alert, and optionally disconnects the load. Simultaneously, the prepaid system tracks energy usage and deducts balance. When the balance reaches zero, the relay disconnects the load automatically. All system parameters are displayed on the LCD and can be monitored remotely. The system uses the ThingSpeak IoT platform for real-time data visualization and remote monitoring of system parameters.

V. RESULTS AND DISCUSSION

5.1 Project View



fig.5.1 project view

The proposed IoT-based Smart Energy Theft Detection System using Current Imbalance Alerts and Prepaid Billing was implemented and tested to evaluate its performance in real-time energy monitoring, theft detection, and prepaid billing management. The system integrates current sensors, a microcontroller, an LCD interface, and IoT cloud connectivity for data visualization and monitoring.

A. Hardware Output and System Operation

The developed prototype successfully displays system information using a 16×2 LCD module. During normal operation, the LCD displays parameters such as remaining prepaid balance, energy consumption values, and billing status. As electrical loads consume energy, the remaining units decrease accordingly.



Fig 5.1(A) LCD displaying remaining balance / billing values)

The system also provides warning messages when abnormal conditions occur. When the prepaid balance approaches the minimum threshold, a low-balance warning is displayed to notify the consumer. This ensures that users are informed about their remaining energy credits in advance.



Fig5.1(B)LCD showing low balance warning



Fig5.1(C) LCD displaying tamper alert / theft detected

To evaluate theft detection capability, a current imbalance was intentionally introduced between the supply and load paths. When the difference exceeded the predefined threshold, the system immediately detected the abnormal condition and displayed the message “TAMPER ALERT – THEFT DETECTED.” This confirms the effectiveness of the current-comparison method used for identifying unauthorized electricity usage.

5.2 IoT Cloud Data Visualization

The monitoring data from the prototype system were transmitted to the ThingSpeak IoT platform for real-time cloud visualization and analysis. Multiple parameters were recorded and displayed using different fields.

Field 1 represents the remaining prepaid units, which decrease over time as energy is consumed. When additional credits are added, the value increases accordingly.

Field 2 corresponds to the billing information, showing the calculated electricity cost based on the consumed energy units. Variations in the graph indicate changes in load usage during the experimental period.



Fig5.2(a) Remaining Units Graph



Fig5.2(b) Billing Graph

Field 3 represents the power supply status, which confirms stable system operation during the testing phase.

Field 4 indicates the theft detection status, where the value 0 represents normal operation and 1 indicates a detected tampering or theft event. The graph shows instances where the system successfully identified abnormal current conditions corresponding to simulated electricity theft scenarios.



Fig5.2(c) Power Status graph



Fig5.2(d) Theft detection graph

C. Performance Evaluation

The experimental results demonstrate that the proposed system effectively performs energy monitoring, prepaid billing management, and real-time electricity theft detection. The integration of IoT cloud monitoring allows remote observation of system parameters, enabling utilities to quickly identify suspicious activity.

Overall, the system provides a reliable and efficient approach for detecting electricity theft while maintaining transparent billing and remote monitoring capabilities.

VI. CONCLUSION

This paper presented an IoT-based smart energy system for electricity theft detection using current imbalance analysis integrated with a prepaid billing mechanism. The proposed system effectively identifies unauthorized electricity usage by comparing supply and load currents and generates real-time alerts for abnormal conditions. The implementation results confirm that the system accurately detects theft scenarios and provides timely notifications through both local display and IoT-based cloud monitoring.

The prepaid billing feature ensures controlled energy consumption by continuously updating the user's balance and automatically disconnecting the load when the balance is exhausted. This not only improves revenue assurance but also promotes efficient energy usage. The integration of sensing, communication, and control mechanisms into a single system enhances overall reliability and reduces the need for manual intervention.

The experimental results demonstrate that the system operates efficiently under both normal and tampering conditions, with accurate monitoring, fast response, and effective remote visualization. Due to its low cost, scalability, and real-time capabilities, the proposed system is suitable for deployment in modern smart grid and energy management applications.

REFERENCES

- [1]. H. S. Chong, "IoT-Based Smart Energy Meter Monitoring with Theft Control," *Journal of Engineering & Technological Advances*, vol. 9, no. 2, pp. 115–130, 2025.
- [2]. P. Jawale et al., "IoT Based Smart Energy Meter Monitoring with Identification of Electricity Theft," *Proc. ICCIP*, 2021.
- [3]. A. Patil et al., "IoT Based Smart Energy Meter with Theft Detection," *Journal of Scientific Research and Technology*, vol. 3, no. 12, pp. 5–9, 2025.
- [4]. N. G. Navadeep et al., "IoT-based Prepaid Smart Energy Meter and Theft Detection," *International Journal for Research in Applied Science & Engineering Technology (IJRASET)*, vol. 13, no. XI, 2025.
- [5]. Z. A. Khan et al., "Electricity Theft Detection Using Machine Learning Techniques," *Sustainability*, vol. 12, no. 19, 2020.
- [6]. L. Anbarasu et al., "Smart IoT Energy Metering System with Real-Time Theft Detection and Prevention," *IRO Journal of Electrical Engineering and Applications*, vol. 7, no. 2, pp. 151–162, 2025.