

# IoT Accident Detection & Smart Emergency Response System

K. Amarender<sup>1</sup>, P. Pavithra<sup>2</sup>, B. Supriya<sup>3</sup>, M. Navya<sup>4</sup>, V. Srikanth<sup>5</sup>

Assistant Professor, Dept. of Electronics & Communication Engineering,

Christu Jyothi Institute of Technology & Science, Jangaon, Telangana, India<sup>1</sup>

UG Student, Dept. of Electronics & Communication Engineering,

Christu Jyothi Institute of Technology & Science, Jangaon, Telangana, India<sup>2-5</sup>

**Abstract:** The rapid increase in road accidents has become a major global concern, often resulting in severe injuries or fatalities due to delayed emergency response and drunk driving. To address these challenges, this project proposes an IoT-based Accident Detection and Smart Emergency Response System integrated with Alcohol Detection. The system uses a vibration sensor to detect sudden vehicle impacts or tilts that may indicate an accident. Simultaneously, an MQ3 alcohol sensor monitors the driver's breath for alcohol concentration.

If the detected level exceeds a preset threshold, the system automatically disables the vehicle ignition and sends an alert message to registered contacts, preventing the driver from operating the vehicle under the influence. In the event of a collision, the GPS module determines the exact location, and the GSM module sends an SMS alert containing the coordinates to emergency services and family members. The system can also be integrated with IoT cloud platforms for real-time monitoring.

This combination of accident detection, alcohol prevention, and automated emergency response ensures faster medical assistance and enhances road safety. The proposed system is cost-effective, reliable, and suitable for integration in both personal and commercial vehicles.

## I. INTRODUCTION

One of the key reasons for such high mortality rates is the delay in providing immediate medical help to the victims. Often, accident locations are remote, and there is no means for bystanders or the vehicle itself to automatically inform emergency services. Manual reporting by witnesses or passers-by takes precious minutes, sometimes hours, which could mean the difference between life and death. Therefore, there is a growing need for an automated system that can detect accidents in real time and immediately alert nearby hospitals, police stations, or emergency responders

At the same time, drunk driving continues to be one of the leading causes of accidents worldwide. Alcohol impairs a driver's judgment, coordination, and reaction time, making it highly dangerous to operate a vehicle under its influence. Existing laws and human policing are not sufficient to prevent such incidents in all cases. Hence, integrating alcohol detection technology directly into the vehicle's system can serve as a proactive measure to stop the engine from starting when the driver is intoxicated, thus preventing potential accidents before they occur.

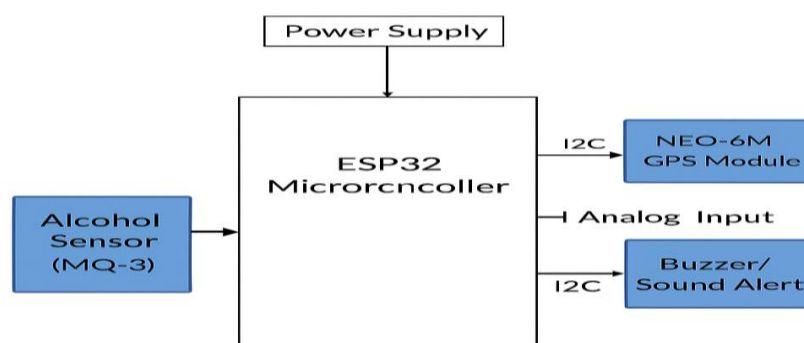

Figure.1: Block diagram

## II. EXISTING SYSTEM

Existing vehicle safety systems provide partial solutions but fail to offer a comprehensive, low-cost, and integrated approach. Premium systems are expensive and brand-specific, smart phone apps are unreliable, alcohol detection devices are inconvenient, and aftermarket solutions lack real-time emergency response. These gaps highlight the need for an IoT-based integrated system that combines accident detection, alcohol prevention, and automated emergency alerts into one platform. Such a solution would democratize road safety, making advanced protection accessible to all vehicles, not just luxury models.

Road safety has been a global concern for decades, and several systems have been developed to reduce fatalities and improve emergency response. Existing vehicle safety solutions can be broadly categorized into built-in vehicle systems, smart phone-based applications, alcohol detection devices, and commercial aftermarket technologies. Each of these has strengths but also notable limitations.

Modern vehicles, especially in developed countries, often come equipped with advanced safety mechanisms. For instance, the eCall system, mandatory in all new EU cars since 2018, automatically contacts emergency services when airbags deploy. It transmits vehicle location, time, and direction, ensuring faster rescue. Similarly, On Star (General Motors) and luxury brand services like BMW Assist or Mercedes mbrace provide crash response, diagnostics, and emergency communication. However, these systems are expensive, brand-specific, and limited to premium vehicles, making them inaccessible to low-cost or older cars. Moreover, they often depend on airbag deployment, which may not trigger in all accident scenarios.

## III. PROPOSED METHOD

This project proposes the development of an intelligent vehicle safety system that addresses two critical aspects of road safety: accident prevention through alcohol detection and automated emergency response during accidents. The system represents a comprehensive approach to vehicle safety by integrating multiple safety features into a unified platform.

The core concept revolves around creating a smart guardian for vehicles that continuously monitors the driver's condition and vehicle dynamics. For accident prevention, the system incorporates continuous alcohol monitoring within the vehicle cabin. When alcohol presence is detected above safe limits, the system automatically prevents vehicle ignition and immediately notifies the vehicle owner about the violation. This preventive approach aims to stop accidents before they can occur by addressing one of the major causes of road accidents - drunk driving.

The proposed system stands out by combining practical engineering implementation with genuine social impact. It demonstrates how modern technology can be leveraged to create solutions that potentially save lives while providing students with hands-on experience in developing complete systems from concept to functional prototype. The project scope allows for thorough exploration of technical challenges while delivering a working system that addresses real-world safety concerns in a meaningful way.

## IV. RESULT

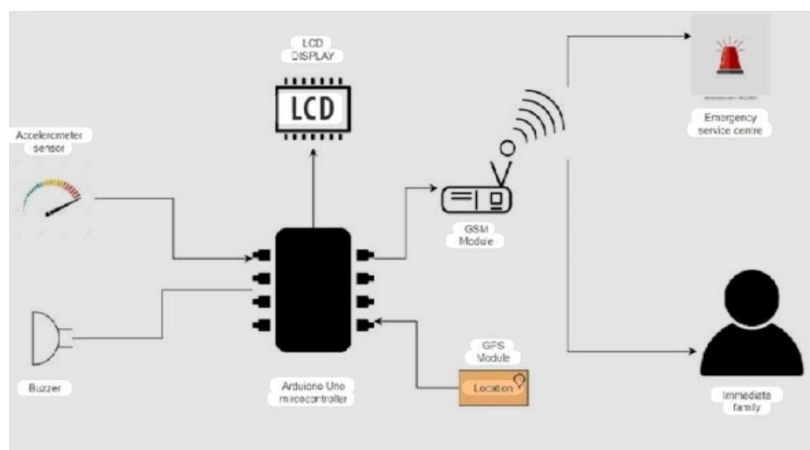

## V. CONCLUSION

The IoT Accident Detection & Smart Emergency Response System with Alcohol Detection represents a significant step toward enhancing road safety and reducing fatalities caused by delayed medical assistance and drunk driving. By integrating vibration and accelerometer sensors for accident detection, GPS and GSM modules for real-time location tracking and alert transmission, and the MQ-3 alcohol sensor for ignition control, the system provides a comprehensive safety solution that is both preventive and responsive.

This project demonstrates how IoT technology can be leveraged to create intelligent, low-cost, and scalable solutions that directly address pressing societal issues. Unlike existing systems that are either expensive, brand-specific, or limited in functionality, the proposed system offers a holistic approach by combining accident prevention, detection, and emergency response into one unified platform.

Beyond its immediate application in personal and commercial vehicles, the system has the potential to be integrated into smart city infrastructures, fleet management systems, and government road safety initiatives. With further development, incorporating AI/ML algorithms, cloud-based monitoring, and V2X communication, the system can evolve into a robust safety ecosystem capable of saving countless lives.

## VI. FUTURE SCOPE

The IoT Accident Detection & Smart Emergency Response System with Alcohol Detection has strong potential for expansion and real-world deployment. Based on the current design and limitations, here are some promising directions for future scope:

- **AI/ML Integration:** Use machine learning algorithms to classify accident severity, reduce false alarms, and prioritize emergency responses.
- **Cloud & Big Data Analytics:** Store accident and driving data on IoT cloud platforms for predictive analysis, trend monitoring, and improving road safety policies.
- **Advanced Sensor Fusion:** Combine accelerometer, gyroscope, and camera-based vision systems for more accurate accident detection.
- **Voice Assistance:** Integrate voice-based emergency reporting for occupants to communicate directly with responders.
  - **5G & Edge Computing:** Enable ultra-low latency communication for faster emergency alerts and real-time monitoring.
- **Multi-Channel Alerts:** Extend beyond SMS to include WhatsApp, email, and app-based notifications for broader reach.
- **Vehicle-to-Everything (V2X):** Allow vehicles to communicate with nearby cars, traffic signals, and emergency services for coordinated responses

## REFERENCES

### Research Articles:

- [1]. IEEE Xplore. (n.d.). *Real-Time IoT-based Vehicle Accident Detection and Emergency Response*. Retrieved from IEEE Xplore.
- [2]. Chithra, V., Vidusha, M., Eldho, A. M., Saleem, S., & Charley, E. J. (2023). *Accident Alert System Using Sensors and IoT Devices*. International Journal of Creative Research Thoughts (IJCRT).
- [3]. Pathik, N., Gupta, R. K., Sahu, Y., Sharma, A., Masud, M., & Baz, M. (2022). *AI Enabled Accident Detection and Alert System Using IoT and Deep Learning for Smart Cities*. Sustainability, 14(13), 7701

### Books:

- **Buyya & Hanes (IoT Fundamentals)** → Strong theoretical foundation for IoT architecture and communication protocols.
- **Springer & Zenodo chapters (2023–2024)** → Directly relevant to accident detection and emergency response systems, similar to your project scope.
- **Embedded Systems with IoT Applications** → Practical coding and hardware integration with ESP32 and sensors like MQ-3, GPS, and vibration sensors.
- **Vehicular Ad Hoc Networks** → Provides context for future scope, especially V2X and smart city integration.