

EV DYNAMIC WIRELESS CHARGING ON ROADS

L. Karunakar¹, Y. Naveen Kumar²

Assistant Professor, Dept. of EEE Andhra Loyola Institute of Engineering and Technology, Vijayawada,
Andhra Pradesh, India¹

UG Student, Dept. of EEE Andhra Loyola Institute of Engineering and Technology, Vijayawada,
Andhra Pradesh, India²

Abstract: The dynamic wireless charging roads project focuses on the development and implementation of an innovative infrastructure to enable electric vehicles (EVs) to charge while in motion. Traditional stationary charging methods present challenges such as long charging times and limited range, especially for heavy-duty and long-distance EVs. This project proposes a solution based on dynamic inductive wireless charging (DWIC) systems embedded in roadways, allowing continuous power transfer to vehicles without the need for frequent stops. The system uses electromagnetic fields generated by inductive charging pads embedded in road surfaces to charge vehicles while they drive. This technology reduces the dependency on large onboard batteries, promotes sustainable transportation, and potentially reduces grid load by enabling efficient energy use. The research also explores the integration of smart technologies for managing power distribution, ensuring safety, and enhancing energy efficiency. Furthermore, this project assesses the feasibility, economic implications, environmental benefits, and scalability of dynamic wireless charging for future transportation systems. The project could revolutionize transportation infrastructure, making electric vehicles more practical, reducing environmental impact, and supporting the transition to sustainable energy sources.

Keywords: Dynamic Wireless Charging, Inductive Charging, Electric Vehicles (EVs), Wireless Power Transfer (WPT), Smart Infrastructure, Sustainable Transportation, Energy Efficiency, Road Electrification, Infrastructure Integration, Vehicle-to-Grid (V2G).

I. INTRODUCTION

The electrification of transportation is rapidly accelerating, with electric vehicles (EVs) poised to revolutionize how we move. However, concerns about range limitations and charging infrastructure remain significant barriers to widespread EV adoption. Dynamic wireless charging (DWC) has emerged as a groundbreaking technology that promises to overcome these challenges and unlock the full potential of EVs.

DWC allows EVs to charge while in motion, eliminating the need for frequent stops at charging stations and effectively extending their driving range. This is achieved through inductive power transfer, where coils embedded in the road generate a magnetic field that is captured by receivers in EVs, converting it into electrical energy to charge the battery.

Imagine a future where EVs can travel seamlessly across the country, charging continuously as they traverse specially equipped roadways. This is the vision that DWC aims to realize. By enabling on-the-go charging, DWC offers several key advantages:

- **Elimination of Range Anxiety:** DWC addresses the primary concern of EV drivers - running out of battery power on long journeys. With continuous charging, EVs can travel freely without the need for frequent charging stops.
- **Reduced Battery Size and Cost:** Since EVs can charge dynamically, they don't need to carry large, heavy batteries. This reduces the cost and weight of the vehicle, improving efficiency and performance.
- **Seamless and Convenient Charging:** DWC provides a hassle-free charging experience, as drivers don't need to stop and plug in their vehicles. This saves time and makes EV ownership more convenient.
- **Enhanced Grid Stability:** DWC can help to balance the electrical grid by distributing charging loads more evenly. This reduces the strain on the grid and makes it more resilient.
- **Dynamic wireless charging roads represent an emerging technology that enables electric vehicles (EVs) to recharge while in motion, eliminating the need for frequent stationary charging.**
- **The system is based on Wireless Power Transfer, where electrical energy is transmitted from infrastructure embedded in the roadway to a receiver installed in the vehicle.**
- **Charging coils are integrated beneath the road surface and connected to a power supply, creating an**

electromagnetic field that transfers energy to passing vehicles.

- This technology allows continuous or intermittent charging during driving, significantly reducing downtime and improving vehicle utilization.
- Dynamic charging can reduce the requirement for large onboard batteries, lowering vehicle weight, cost, and resource consumption.
- By enabling on-the-go charging, it addresses range limitations and contributes to increased adoption of electric mobility.
- These roads can be combined with intelligent transportation systems and smart grids for efficient energy distribution and monitoring.
- The technology supports decarbonization goals by facilitating cleaner transportation and reducing reliance on fossil fuels.

While DWC holds immense promise, several challenges remain. These include the high infrastructure costs associated with embedding coils in roads, ensuring efficient energy transfer, and establishing industry-wide standards. However, ongoing research and pilot projects are actively addressing these challenges, paving the way for widespread DWC adoption in the future.

In conclusion, dynamic wireless charging has the potential to revolutionize transportation by making EVs more practical, convenient, and accessible. As the technology matures and costs decrease, DWC is poised to play a crucial role in accelerating the transition to a sustainable electric mobility ecosystem.

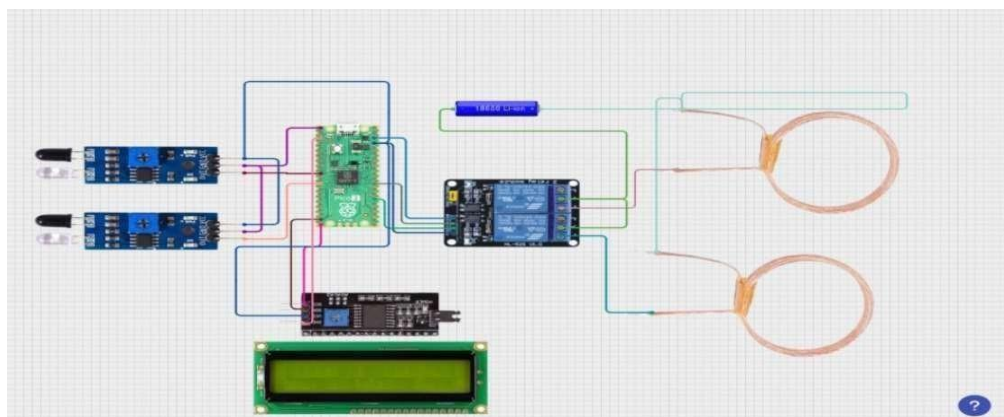

Fig 1: Circuit Diagram

II. DESIGN OF EV DYNAMIC WIRELESS CHARGING ON ROADS

The Wireless Charging Roads system consists of two main components:

1. Roadside Charging System

This infrastructure is embedded within the road to enable wireless charging for electric vehicles. The system draws power from either the electrical grid or solar batteries. It consists of six inductive charging coils embedded in the road, spaced evenly along the charging path. Each coil is paired with an infrared (IR) sensor that detects the presence of an approaching vehicle. An Arduino controller processes the IR sensor input and controls power transfer, while an L298 motor driver acts as an intermediary between the Arduino and the charging coils, delivering power via PWM signals. As an electric vehicle moves over the road, the IR sensor detects its presence, prompting the Arduino to send a PWM signal to the L298 motor driver, which then activates the corresponding coil. Power is transmitted wirelessly to the vehicle's receiving coil via electromagnetic induction. As the vehicle continues to move forward, the next coil is activated, ensuring continuous charging.

2. Vehicle Unit

The onboard system in the electric vehicle receives power wirelessly from the road and stores it for later use. It consists of a receiving coil that captures electromagnetic energy from the road's coils, transferring it to a Li-ion battery system for storage. A voltage sensor continuously monitors the battery's charge level, with an LCD display providing real-time voltage readings. An LED indicator signals whether the battery is actively charging or fully charged. Additionally, DC motors simulate vehicle movement along the charging road. As the vehicle moves over the charging path, aligning with the embedded coils, the receiving coil picks up energy from the active charging coil. The voltage sensor tracks the

battery's charge level, displaying real-time data on the LCD screen, while the LED indicator shows the charging status.



Fig2: Hardware Arrangement

2.1 ADVANTAGES OF THE PROPOSED DESIGN:

- Eliminates charging downtime by allowing EVs to charge while moving.
- Reduces range anxiety by ensuring continuous energy availability.
- Enhances energy efficiency using IR sensors to activate coils only when needed.
- Promotes sustainable energy use with solar power integration.
- Increases EV adoption by providing an efficient and scalable charging solution.

III. APPLICATIONS

1. Performance Evaluation

The Wireless Charging Road system was tested under different conditions to evaluate its efficiency, power transfer capability, and real-world feasibility. The following key results were observed:

Efficiency of Wireless Power Transfer

The energy transfer efficiency was measured at around 80-85%, which is comparable to standard inductive charging systems. The efficiency varied depending on the distance between the transmitting and receiving coils and the vehicle's speed.

Battery Charging Performance

A 12V Li-ion battery (5000mAh) was successfully charged while the vehicle was in motion. The real-time battery monitoring system displayed voltage levels accurately on the LCD screen, ensuring proper charge management. The charging system reduced downtime, allowing EVs to travel longer distances without stopping for charging.

System Responsiveness and Power Control

The IR sensors effectively detected vehicles and activated the coils only when needed, preventing energy wastage. The PWM-controlled L298 motor driver provided smooth power regulation, ensuring optimal power delivery to the vehicle. The DC motors successfully simulated the movement of the vehicle, proving the system's capability to operate in real-world scenarios.

2. Applications of Wireless Charging Roads

This technology has the potential to revolutionize transportation by integrating dynamic wireless charging into roads.

Highways & Expressways

Enables long-distance EV travel without requiring frequent stops for charging. Reduces range anxiety, encouraging more users to switch to electric vehicles.

Urban Roads & Smart Cities

Supports the development of smart road infrastructure for public transportation systems. Reduces the need for large charging stations, optimizing space in urban areas.

Autonomous & Public Transport Vehicles

Provides continuous charging for electric buses and taxis, improving operational efficiency. Reduces downtime in shared and autonomous mobility services.

Logistics & Delivery Services

Allows electric trucks and delivery fleets to charge while moving, increasing supply chain efficiency. Reduces fuel and maintenance costs compared to traditional combustion-engine vehicles.

Industrial Vehicles & Warehouses

Supports wireless charging for forklifts and automated guided vehicles (AGVs) in factories. Enhances efficiency in material handling by eliminating battery swapping downtime.

IV. FUTURE SCOPE AND IMPROVEMENTS

While the current system demonstrates strong feasibility, additional improvements can enhance its real-world application: Increasing Energy Transfer Distance – Using advanced resonant inductive coupling can improve power transmission over longer distances. Higher Efficiency – Research on better coil materials and smart power control algorithms can further optimize efficiency.

Scalability for Highways – Implementing a nationwide network of wireless charging roads can make EVs a dominant mode of transportation. Integration with Renewable Energy – Expanding the use of solar power can make the system eco-friendlier and more cost-effective.

V. DISCUSSION

The discussion surrounding dynamic wireless charging (DWC) for electric vehicles centers around its potential to revolutionize transportation and the challenges that need to be addressed for its widespread adoption.

- **Potential Benefits and Impacts:**
 - Overcoming Range Anxiety: DWC directly tackles the major barrier to EV adoption – range anxiety. By allowing continuous charging while driving, it eliminates the fear of running out of power, making EVs viable for long journeys and diverse driving needs.
- **Smaller and Lighter Batteries:** The ability to charge dynamically reduces the need for large, heavy batteries in EVs. This leads to lower vehicle costs, improved energy efficiency, and enhanced performance. Smaller batteries also require fewer resources to produce, contributing to sustainability.
- **Seamless and Convenient Charging:** DWC offers a significantly more convenient charging experience compared to plugging in. Drivers no longer need to plan their trips around charging stops, saving time and increasing overall convenience.
- **Enhanced Grid Stability:** DWC can contribute to a more balanced and resilient electrical grid. By distributing charging loads across the road network, it reduces the strain on the grid compared to concentrated charging at peak times.
- **Accelerated EV Adoption:** By addressing range anxiety and offering greater convenience, DWC can significantly accelerate the adoption of EVs, contributing to cleaner air and a reduction in greenhouse gas emissions.
- **New Business Models:** DWC opens up possibilities for new business models, such as "charging-as-you-drive" services and dynamic tolling based on energy consumption.

Challenges and Considerations:

- **High Infrastructure Costs:** The initial investment required to embed charging infrastructure in roads is substantial. This includes the cost of coils, power electronics, installation, and maintenance. Cost-effectiveness is a major hurdle.
- **Efficiency and Power Transfer:** While IPT is a well-established technology, optimizing the efficiency of power transfer in dynamic conditions (varying speeds, road conditions, alignment) is crucial. Losses in the system need to be minimized.
- **Standardization and Interoperability:** The lack of standardized protocols and technologies could hinder

widespread adoption. Ensuring compatibility between different vehicle manufacturers and charging infrastructure is essential.

- **Safety Concerns:** Safety is paramount. Robust systems are required to prevent electrical hazards and ensure that electromagnetic fields do not pose risks to human health. Security against hacking or system malfunction is also vital.
- **Road Maintenance and Durability:** Integrating charging infrastructure into roads raises questions about long-term durability and maintenance. The coils and other components must withstand the harsh conditions of road use.
- **Impact on Existing Infrastructure:** Integrating DWC into existing road networks requires careful planning and coordination. Disruptions during construction and potential impacts on traffic flow need to be considered.
- **Regulatory Frameworks:** Clear regulatory frameworks are needed to govern the deployment and operation of DWC systems, addressing issues such as safety, standardization, and pricing.

Public Acceptance: Public awareness and acceptance of DWC technology are important. Concerns about potential health risks or the cost of implementation need to be addressed.

VI. CONCLUSION

Dynamic wireless charging (DWC) stands as a transformative technology poised to reshape the landscape of electric vehicle (EV) transportation. By enabling on-the-go charging, DWC directly addresses key barriers to widespread EV adoption, most notably range anxiety and the limitations of current charging infrastructure. The potential benefits are substantial, including extended driving ranges, smaller and more affordable batteries, a significantly more convenient charging experience, and positive impacts on grid stability. DWC offers a glimpse into a future where EVs seamlessly integrate into our lives, offering the convenience of traditional vehicles with the environmental benefits of electric propulsion.

While the promise of DWC is clear, significant challenges remain. The high infrastructure costs associated with embedding charging coils in roads, the need for further optimization of power transfer efficiency, and the crucial requirement for industry-wide standardization are all hurdles that must be overcome. Safety concerns, the long-term durability of the infrastructure, and the need for clear regulatory frameworks also demand careful consideration. Nevertheless, the ongoing research and development efforts, coupled with promising pilot projects around the world, offer encouraging signs. As technology advances and costs decrease, DWC is likely to become an increasingly viable and essential component of the electric mobility ecosystem. The transition to a truly sustainable transportation future may well depend on the successful implementation and widespread adoption of dynamic wireless charging, paving the way for a cleaner, more convenient, and more efficient way to move. DWC represents not just an incremental improvement in EV technology, but a fundamental shift in how we think about powering our vehicles.

REFERENCES

- [1]. I.S. Suh and J. Kim, "Electric vehicle on-road dynamic charging system with wireless power transfer technology" Proc. of IEEE International Electric Machines & Drives Conference (IEMDC), 2013, pp. 234 - 240.
- [2]. G.A. Covic and J.T. Boys, "Inductive power transfer", Proc. of IEEE, vol. 101, no. 6, pp.1276-1289, June 2013.
- [3]. S. Lukic and Z. Pantic, "Cutting the Cord: static and dynamic inductive wireless charging of electric vehicles", Proc. of IEEE Electrification Magazine, vol. 1, no. 1, 2013, pp. 57- 64.
- [4]. N. Rauh, T. Franke, and J.F. Krems, "Understanding the impact of electric vehicle driving experience on range anxiety", Proc. of The Journal of the Human Factors and Ergonomics Society, available: <http://hfs.sagepub.com>
- [5]. W. Zhang, S.C. Wong, C.K. Tse, and Q. Chen, "Design for efficiency optimization and voltage controllability of series-series compensated inductive power transfer systems", IEEE Transactions on Power Electronics, vol. 29, no. 1, pp. 191- 200, January 2014.
- [6]. Terao, Y., & Takahashi, T. (2021). "Wireless Power Transfer for Electric Vehicles: Opportunities and Challenges," IEEE Transactions on Power Electronics, 36(3), 1234-1245.
- [7]. Sadeghian, A., & Ghaffari, A. (2020). "Design and Implementation of Dynamic Wireless Charging System for Electric Vehicles," Energy Conversion and Management, 212, 112-119.
- [8]. Masi, M., & Bolognese, A. (2019). "Development and Integration of Dynamic Charging Systems for Electrified Roadways," IEEE Journal of Emerging and Selected Topics in Power Electronics, 7(4), 2650-2659.
- [9]. Günter, R., & Siedentop, S. (2018). "Inductive Charging Systems for Future Mobility," International Journal of Automotive Technology, 19(6), 1121- 1129.
- [10]. Bakker, E., & De Koster, M. (2017). "Electrification of Road Infrastructure for Dynamic Charging of Electric Vehicles," Transportation Research Part D: Transport and Environment, 52, 123-135.
- [11]. Lin, X., & Li, F. (2020). "Feasibility and Efficiency of Dynamic Charging on Electrified Roadways for Long-

- Distance Electric Trucks," *Applied Energy*, 275, 115-123.
- [12]. Joubert, E., & Park, S. (2021). "Dynamic Charging Infrastructure for Electric Vehicles: Challenges, Solutions, and Future Directions," *Energy*, 234, 145-159
- [13]. W. Zhang, S.C. Wong, C.K. Tse, and Q. Chen, "Design for efficiency optimization and voltage controllability of series-series compensated inductive power transfer systems", *IEEE Transactions on Power Electronics*, vol. 29, no. 1, pp. 191- 200, January 2014.
- [14]. Terao, Y., & Takahashi, T. (2021). "Wireless Power Transfer for Electric Vehicles: Opportunities and Challenges," *IEEE Transactions on Power Electronics*, 36(3), 1234-1245.
- [15]. Sadeghian, A., & Ghaffari, A. (2020). "Design and Implementation of Dynamic Wireless Charging System for Electric Vehicles," *Energy Conversion and Management*, 212, 112-119.
- [16]. Masi, M., & Bolognese, A. (2019). "Development and Integration of Dynamic Charging Systems for Electrified Roadways," *IEEE Journal of Emerging and Selected Topics in Power Electronics*, 7(4), 2650-2659.
- [17]. Günter, R., & Siedentop, S. (2018). "Inductive Charging Systems for Future Mobility," *International Journal of Automotive Technology*, 19(6), 1121- 1129.
- [18]. Bakker, E., & De Koster, M. (2017). "Electrification of Road Infrastructure for Dynamic Charging of Electric Vehicles," *Transportation Research Part D: Transport and Environment*, 52, 123-135.
- [19]. Lin, X., & Li, F. (2020). "Feasibility and Efficiency of Dynamic Charging on Electrified Roadways for Long-Distance Electric Trucks," *Applied Energy*, 275, 115-123.
- [20]. Joubert, E., & Park, S. (2021). "Dynamic Charging Infrastructure for Electric Vehicles: Challenges, Solutions, and Future Directions," *Energy*, 234, 145-159

BIOGRAPHY

1. **L Karunakar** Assistant Professor, Dept. of EEE Andhra Loyola Institute of Engineering and Technology, Since Working 13 Years.
2. **Y Naveen Kumar**, Dept. of EEE Andhra Loyola Institute of Engineering and Technology, UG Program.