

# IOT BASED FAULT DETECTION SYSTEM IN TRANSMISSION LINES

V. ABHINAV<sup>1</sup>, V MAHESH BABU<sup>2</sup>, N. VEERA SIMHA REDDY<sup>3</sup>, K. RAVI TEJA <sup>4</sup>,

**Dr.G.GANTHAI AH SWAMY<sup>5</sup>**

<sup>4</sup>th Year EEE, Andhra Loyola Institution of Engineering and Technology, Vijayawada, Andhra Pradesh, India<sup>1-4</sup>

EEE, Andhra Loyola Institution of Engineering and Technology, Vijayawada, Andhra Pradesh, India<sup>5</sup>

**Abstract:** The project's main objective is to design and implement automatic problem detection and location identification in transmission lines, as well as monitoring using the internet of things. Two single phase 230V transmission lines are being built for demonstration purposes, with continuous monitoring of the microcontroller's fault sensing. A sophisticated GSM-based defect detection and localization system was deployed to quickly and accurately pinpoint the precise spot where the problem had developed. The system provides precise fault location information, significantly cutting down on the time required to locate a flaw.

**Keywords:** Microcontroller (Arduino UNO / Nano / ESP32), Current Sensor (CT + burden / ACS712), Voltage Sensor Module, Fault Simulation Switches (L-G, L-L, L-L-G), Relay Module (Load isolation), LCD (16×2) / OLED, Buzzer (optional), GSM / IoT Module (SIM800 / ESP8266), Power Supply (12V → 5V regulated), Connecting wires & breadboard / PCB.

## I. INTRODUCTION

Electrical Power System is basically an energy supply system which consist of power generation, transmission and distribution sectors. All these factors plays important role for supplying energy to consumer and transmission lines around the world which is one prominent feature among all. A transmission line is used for transmitting electrical power from generating station to various distribution units which transmit current and voltage from source to several consumer units. The transmission line is made up of a conductor having a uniform cross-sectional area along the line. Air act as an insulating or dielectric medium between the conductors [1].

Since Power system consists of many powerful equipment operating in HV mode where expected or unexpected fault can occur at any time due to any reason. Mostly the faults occur in transmission sector of power system which could be due to high velocity wind, heavy rainfall or any other technical issue etc. and this can cause interruption to the power system [2].

Interruption in power system can cause damage to the operating equipment whose severity depends upon the type of fault occurs. If the fault is not cleared immediately it will result in loss of synchronization, loss of budget or may destroy the network as well as can cause huge damage to the system [3].

To overcome these challenges, smart monitoring and fault detection system using digital sensors is proposed. Whenever any fault occurs in system, the system will send a fault alert notification to the utility IoT cloud server in which user will be informed regarding the fault occurred in transmission line. Hence with this system, almost real time monitoring is achieved. After receiving the exact information regarding faults, it will be easier for the user to isolate the faulty part of the system from the healthy one. Hence this system will give accurate information related to faults and transmission line can be monitored from everywhere using web server.

### 1.1 Objectives

The main aim of this project is to design a circuit or a device which will have a capability of determining the type of fault, exact location of fault and transfer its data to the utility mobile phone and desktop of the user with the help of GPS and NodeMCU.

The Main objectives of this project are:

- To simulate the system using programmable controller, current sensor and design a hardware prototype of a system for overhead transmission line.
- To monitor the system under normal and faulty conditions using NodeMCU and clear the fault as soon as

identified.

- To determine the exact location of fault in the transmission line with the help of GPS and send its data to the mobile phone and desktop of user.
- To validate the system performance by applying the faults at different locations in order to check the efficiency of the system.

### 1.2 Significance of Research

This research will allow to understand different types of faults that can occur in real time transmission lines. Moreover this research will also enable us to study different parameters of the transmission line. With the help of this research, the basic knowledge regarding microcontroller GPS and NodeMCU will be provided which are the core components of this project.

The data gathered from this study would enable the authors to produce benchmark research papers, theories and fault detection system which will be improved version of the existing electrical power system.

## II. LITERATURE REVIEW

### 2.1 Introduction

This section of the report provides an extensive literature, core reason and principle of power system protection (especially transmission lines). Initially, the general protection of power system is discussed, followed by common faults which occur in transmission lines. After this, protection of transmission lines is brought into discussion along with the comprehensive analysis of the proposed work.

### 2.2 Background

A decade ago, several electricity supplier corporations opted to make minimal or no expenditure in the development of fault detection processes and systems. This is primarily attributed to the assumption that, many of the errors are temporary ones which do not require any knowledge regarding their positions to diagnose. On the other hand, the unreliable and inaccurate readings, functions of the initial and earliest fault detectors might have been played a key part in this reliance. Therefore, a significant number of research findings are proposed for the location of fault determination as stated in the chapter. However, several organizations and electricity supplier companies have given very less attention to such harsh efforts. Their perceptions have lately transformed due to emerging ideas of free-marketing and deregulation around the globe. These dynamic conditions push businesses and companies to transform their practices in order to save time and resources and to offer a quality service. As a result, the effects of fault position prediction techniques are gradually considered. Everywhere now, it is very popular for virtually all advanced designs of multi-function line surveillance and protection systems to have different fault position estimation procedures. Although, for the accurate detection of fault range, the distance relays weren't really precise enough, the previous research works were aimed to establish dedicated fault position identification systems by calculating the response from the transmit point to the fault location [6]. The research paper provides the earliest approaches that were used for the identification of fault location briefly. However, these quick and estimated techniques have not given the desired precisions regarding the fault location and often suffered from restricted accuracy. After that, in the fifties of the last century, the first generation of wave-based fault detection equipment were implemented in the field [7]. The fundamental concept behind these techniques was to calculate the time for the inserted pulse to pass between the point of injection and the spot where the fault has been occurred. At that time these travelling wave-based techniques were impressively successful relative to 'Reactance- Based' techniques however, they were eventually discarded because of the consistency and reliability concerns and the budgetary factor [8]. Later, the major advancements have been made in the injection and detection of moving wave signals, as well as advanced approaches, allow moving wave-based fault detectors to represent powerful rivals for other fault detection approaches. This method is used a lot for the fault position and several research papers were written to use this method for the purposes of fault position identification. Traveling wave-based systems, however, always face problems from various vulnerabilities and drawbacks like bad weather conditions, humidity, etc [8, 9]. The paper presents another way to analyses the propagated transient waves and capture it in currents or voltages during transmission line faults [10]. The researchers have been working to create a modern and enhanced impedance based system for fault locators in transmission lines and it's become the focal point for the researchers because of the advancement in solid-state relays and in technologies related to electronics or digital. These techniques will efficiently provide advantage from the statistical capacity of microprocessors to build advanced digital fault position systems. Every system and component have its own features, benefits, and limitations. These fault locators are generally distinctive in that they do not need any specialized component relative to travelling waves. The electronic or digital relaying was first established in the late 1960s in order to introduce all machine safety devices in a substation [11]. In 1971, a fault locator system with its

first outline was proposed and it was digital range protection system [12]. After the passage of one year in 1972, the companies Westinghouse and Pacific Gas & Electric Company in USA implemented and tested the first working principle of the digital relay for the line safety [13, 14]. For distance protection and safety applications purposes, in 1975, the “Fourier Transform” was used to calculate the specific components of voltage and current phases [15]. In the starting of 1980s, the “Digital Fourier Transform” (DFT) and the “Fourier Transform” with moving window was introduced, applied, and evaluated for the identification of fault in power system [16, 17]. The creation of the basis of this art was followed by an immense amount of contributions. These methods have also been widely used to build ‘impedance-based.

### **III. RESEARCH METHODOLOGY**

#### **3.1 Introduction**

This thesis focuses on locating fault in transmission line and there location then sending this information to Control Room, Android app and web servers. Four current sensors are connecting in series with the sending end of transmission line and the output of current sensors is attached at the input side of the Microcontroller. When the fault occurs in transmission line the Microcontroller find the fault type and there location utilizing the GPS which is also attached with the micro-controller [8].

The GPS is used to provide the accurate location of the fault and Android app is used to monitor fault type, fault current and there exact location where the fault is occurred in the overhead transmission line. The obtained results is also displayed on the LCD screen to monitor all these parameters on control room. This project can detect four types of faults in overhead transmission line namely, single line to ground fault, double line fault, double line to ground fault and three phase fault. For the development of transmission lines, we use 22-guage wire with 16 resistance of 100 ohms and three 220v to 12v step down transformers [9].

This chapter provide the complete procedure of the system’s Operation that are described as follows:

#### **3.2 Arduino Board**

##### **3.2.1 Overview**

Arduino is an electronic creation platform. Which is free, adaptable and simple to involve equipment and programming for creators and engineers. This allows you to make various kinds of single-board microcomputers to which the community of creators can give various sorts of utilization. A microcontroller board based on the ATmega2560 is called an Arduino Mega. It has 54 digital I/O pins (14 are for pulse width modulation), AI pins, with Powered with the help of a computer, laptop AC-DC adapter or a battery. It is compatible with most of the devices and can perform a lot of functionality. It is widely used for multiple purposes because of ease of handling and a number of functions which this board provides.

##### **Power**

This microcontroller is powered with the help of a USB cable or an external battery or even power supply. Automatic selection of power source occurs.

External power source is based on an adapter (which is based on AC-DC conversion). It is plugged in the power jack of the board which is at one end of the microcontroller. Additionally, power can be supplied from a battery. The two terminals of a battery are inserted inside the input voltage and ground pins of the Arduino.

The voltage operating range of the board is six to twenty volts. However the favorable working limit without destroying the board is from seven to twelve volts. less than seven volts means the voltage is unstable and the board will not deliver full output. for more than twelve volts, overheating of the voltage regulator occurs and the board can get damaged.

Arduino mega2560 is unique and differs from other boards because it doesn’t contain a USB to serial driver chip. ATmega8U2 is used as a USB-Serial converter.

The power pins are as follows:

- **INPUT VOLTAGE.** It is the part which provides input operational voltage to the Arduino board. This is when we are using an external power source to power the microcontroller. voltage can be directly supplied through this power jack or it can be accessed through the specified pin.
- **5VOLT.** It can be provided through USB connection or external power source like battery or power supply.

This is to power the board and to on its functionality mode. External power supplies are connected either through pins or power jack.

- Another supply of 3.3 volt is formed by the regulator present on the board Maximum current capacity is 50mA.
- GROUND. Provides ground connection.

## Input and Output

All of the available digital pins (54) can either be assigned an input or an output status This is done with the help of command digital Read() or digital Write() under pin Mode() functions. The operational voltage level is five volts and these pins can provide or receive maximum up to forty milliamps. An internal resistor is present which is disconnected by default and has a value of 20-50 Kilo Ohms. Moreover, specific functions of some pins are given as:

**Serial Pins:** Serial pins are used to receive and transmit serial data with the help of RX and TX pins. USB to TTL serial chips are also connected to pin zero and pin one. 0 (Receiver) and 1 (Transmitter); 1: 19 (Serial receiver) and 18(Transmitter); 2: 17 (Serial receiver) and 16 (Transmitter); 3: 15 (Serial receiver) and 14 (Transmitter).

**External Interrupts Pins:** Interrupt() function is used to see the details of interrupt functions. Generally it is known that for interrupts 2 corresponds to 0, 3 corresponds to 1, 18 corresponds to 5, 19 corresponds to 4, 20 corresponds to 3, and 21 corresponds to 2. Configuration of these pins are done in order to control and trigger an interrupt.

- **PWM Pins:** It extends from pin 0 to pin 13. analog Write() function is used to obtain 8 bit or 1 byte pulse width modulation (PWM) output.
- **SPI Pins:** 4 pins are for SPI communication but the SPI library is mandatory for proper working. Pin 50 is for MISO, pin 51 is for MOSI, pin 52 is for SCK, pin 53 is for SS. These SPI pins are also connected with the ICSP header,
- **LED 13 Pin.** An LED is connected internally to pin number 13. It is on when high command is passed whereas it is off when low command is passed in the Arduino IDE programming portion.
- **I2C Pin:** Pin 20 is for SDA and pin 21 is for SCL. It is used to support communication with the help of a wire library. I2C is related to TWI.

The Arduino Mega2560 also contains sixteen AI pins for analog functionality. These pins are of 10 bits resolution which means that they have 1024 numbers of various possible values. They range from 0 to 5 volts. changes can be made in the upper and lower end of the range with the help of the Reference() command in the programming.

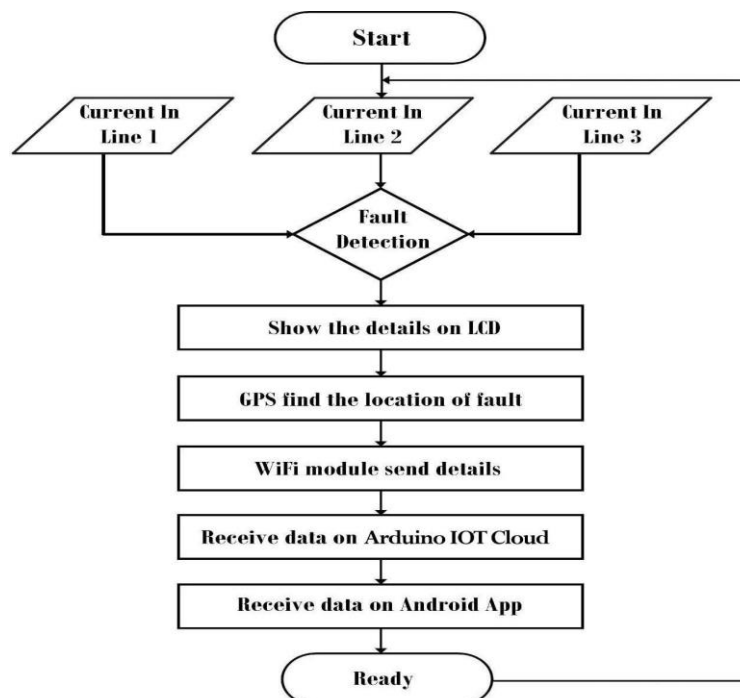

Figure 5. Arduino Mega 2560

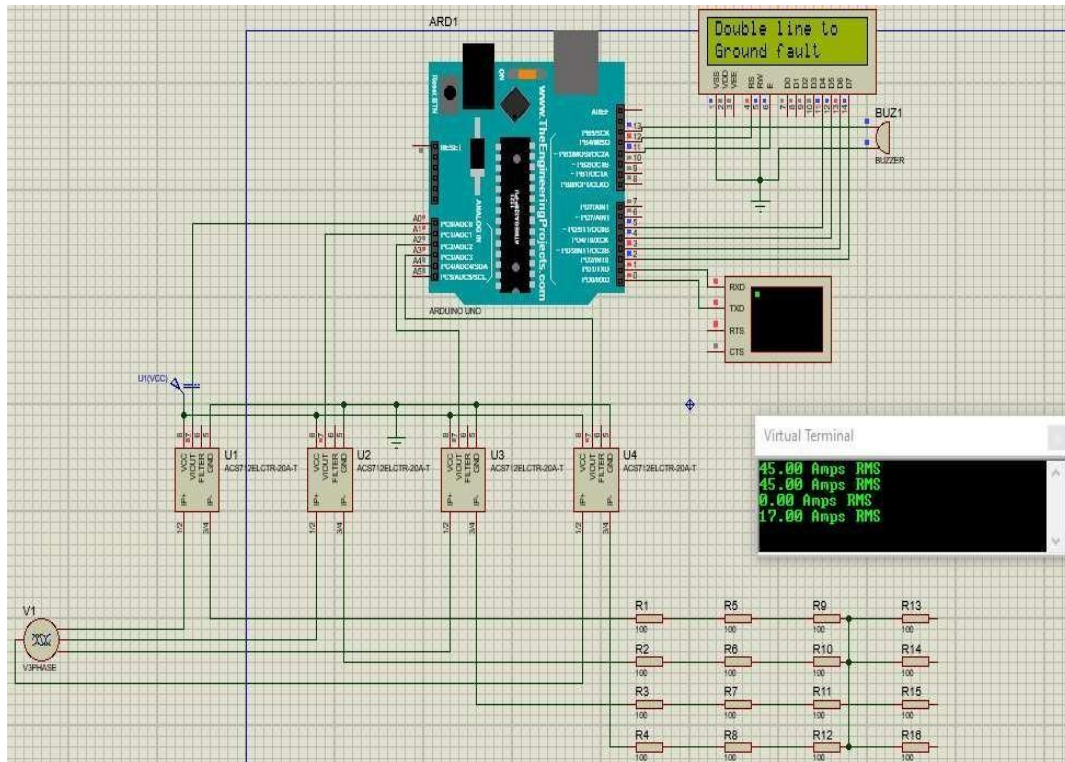

Fig: TRANSMISSION LINE FAULT DETECTION USING IOT

IV. CONCLUSION

The Preliminary researches which have recommended strategies for the protection of transmission lines, mostly rely upon the travelling waves [12]. Even though such systems have the potential and ability to distinguish and find faults on the distribution lines yet these systems are unable to determine the exact location of the fault. Simple analog methods were introduced by various researchers in the past and they were mostly based on waves to detect the faults in the system [13]. The methods using analog advancements have various limitations which is the reason for working on new innovations [14].

The approach used in this project, for the development of fault detection system, uses a variety of hardware equipment’s including GPS, NodeMCU, Arduino, ACS712 Current Sensor Module, LCD display. The system can determine the fault location accurately by using the GPS module [15, 16]. Faults which can be identified by the system are: single line fault, single line to ground fault, double line fault and double line to ground fault. Consequently when a fault occurs in the transmission line, GPS will detect the location of the fault and then a message will be sent to the control room via NodeMCU for immediate response and all this information will also be displayed on the LCD screen.

Future Recommendations

In future, it is recommended to utilize further advance algorithms such as Artificial Intelligence, Machine Learning or Deep Learning in the monitoring of power systems and detection of fault location in transmission lines accurately

ACKNOWLEDGMENT

We shall remain grateful to our Director Rev.Fr. Francis Xavier S. J, and principal Dr.O.Mahesh for their encouragement and for the facilities provided during the course of project. We are very thankful to our beloved Head of the Dept Dr. G. Naveen Kumar, Dept of Electrical and Electronics Engineering (EEE), Andhra Loyola Institute Of Engineering And Technology (ALIET), Vijayawada. We express our deep sense of Gratitude to our Major-project Guide Dr. G. GANTHAI AH SWAMI sir, Dept of Electrical and Electronics Engineering (EEE), Andhra Loyola Institute Of Engineering And Technology (ALIET), Vijayawada for his immense interest, inspiring guidance and whole hearted involvement and also for his valuable suggestions at each and every phase of our project work particularly express our heart full thanks for his supervision, inspiration and timely help in completion of this project. We would like to express our thanks to all the teaching and non-teaching staff of our Electrical and Electronics

Engineering Department for their encouragement and support in successful completion of the project. We wish to express our gratitude and thanks to all the people who helped us in making this endeavor a reality. We thank to our parents for their motivation, inspiration, support and providing me all time help which has make us to come on this platform.

#### REFERENCES

- [1]. C. R. Paul, *Analysis of multiconductor transmission lines*. John Wiley & Sons, 2007.
- [2]. S. R. Fahim, S. K. Sarker, S. Muyeen, S. K. Das, I. J. I. J. o. E. P. Kamwa, and E. Systems, "A deep learning based intelligent approach in detection and classification of transmission line faults," vol. 133, p. 107102, 2021.
- [3]. D. F. Williams, R. B. J. I. M. Marks, and g. w. letters, "Accurate transmission line characterization," vol. 3, no. 8, pp. 247-249, 1993.
- [4]. A. Mukherjee, P. K. Kundu, and A. J. J. o. T. I. o. E. S. B. Das, "Transmission line faults in power system and the different algorithms for identification, classification and localization: a brief review of methods," vol. 102, no. 4, pp. 855-877, 2021.
- [5]. M. Singh, B. Panigrahi, and R. Maheshwari, "Transmission line fault detection and classification," in *2011 International Conference on Emerging Trends in Electrical and Computer Technology*, 2011, pp. 15-22: IEEE