

IOT BASED WORKERS SAFETY HELMET WITH REAL TIME HEALTH MONITORING

P. Prabakar¹, Ch. Pravalika², K. Sravanthi³, Y. Samatha⁴, E. Deena⁵, N. Kalyani⁶

Asst. Professor's, Dept. of Electrical & Electronics Engineering,

Christu Jyothi Institute of Technology & Science, Jangaon, Telangana, India^{1,2}

UG Student, Dept. of Electrical & Electronics Engineering,

Christu Jyothi Institute of Technology & Science, Jangaon, Telangana, India³⁻⁶

Abstract: The safety of workers in hazardous environments such as mining, construction, and manufacturing industries is a major concern. Traditional helmets provide only physical protection and cannot monitor the worker's health condition or environmental hazards. This project proposes an IoT-based smart safety helmet that continuously monitors the worker's health parameters and surrounding environment using sensors and IoT communication. Sensors such as heart rate sensor, temperature sensor, gas sensor, and motion sensor are integrated with a microcontroller like ESP32. The collected data is transmitted to an IoT cloud platform for real-time monitoring.

Keywords: IoT, Smart Helmet, Worker Safety, Health Monitoring, Gas Sensor, Real-Time Monitoring

I. INTRODUCTION

The Internet of Things (IoT) connects devices through the internet to collect and exchange data. By integrating IoT with wearable helmets, worker health and environmental conditions can be monitored in real time. Worker safety is a major concern in industries such as construction, mining, manufacturing, and oil and gas. These environments often expose workers to hazardous conditions including high temperatures, toxic gases, heavy machinery, and physically demanding tasks. Despite the use of traditional safety equipment such as helmets, gloves, and protective clothing, accidents and health issues among workers still occur frequently. Conventional safety helmets mainly protect workers from physical injuries caused by falling objects or head impacts, but they do not provide any mechanism to monitor the worker's health condition or surrounding environmental hazards.

With the rapid development of the Internet of Things (IoT), smart wearable devices have become increasingly popular in industrial safety applications. IoT technology enables devices equipped with sensors to collect data, process information, and transmit it over the internet for real-time monitoring and analysis. By integrating sensors, microcontrollers, and wireless communication modules into safety equipment, it is possible to continuously monitor both environmental conditions and the health status of workers.

An IoT-based worker safety helmet can be designed to monitor parameters such as body temperature, heart rate, and the presence of harmful gases in the environment. These sensors collect real-time data and transmit it to a centralized monitoring system or mobile application. If any abnormal condition is detected, such as exposure to dangerous gases or sudden changes in health parameters, the system can immediately trigger alerts to warn both the worker and the supervisor.

The implementation of such smart helmets can significantly improve workplace safety by enabling continuous monitoring, early detection of hazardous conditions, and faster emergency response. This technology can help reduce workplace accidents, improve worker health monitoring, and ensure better safety management in industries where workers operate in risky environments.

Therefore, the proposed project focuses on designing and developing an IoT-based worker safety helmet with real-time health monitoring to enhance worker protection and provide a smart solution for industrial safety management.

II. LITERATURE SURVEY

Researchers have developed various IoT-based wearable devices to enhance industrial safety. Smart helmets equipped with sensors can detect harmful gases, monitor environmental temperature, and track worker health conditions. Wireless technologies such as Wi-Fi enable real-time monitoring and alert generation.

1. IoT Smart Helmet for Construction Worker Safety

A study by researchers in the Journal of VLSI Design Tools & Technology proposed an IoT-enabled smart helmet designed to improve worker safety at construction sites. The system integrates sensors and wireless communication modules to transmit real-time data to a monitoring system. The helmet continuously tracks environmental and worker-related parameters, helping supervisors detect dangerous conditions and prevent accidents. The research shows that IoT-based wearable systems can significantly reduce workplace hazards by providing continuous monitoring and rapid alerts.

2. Smart Helmet with Environmental Monitoring Sensors

Another research work developed a smart helmet equipped with gas, temperature, and humidity sensors connected to a microcontroller. The device collects environmental data and transmits it to a web or mobile application for remote monitoring. When dangerous gas levels are detected, the system activates alarms to warn workers immediately. This design demonstrates how IoT-based wearable devices can provide real-time awareness of hazardous working environments.

3. IoT-Driven Helmet for Mining Safety

Mining is one of the most dangerous occupations due to toxic gases and extreme environmental conditions. Researchers proposed an IoT-based helmet that uses sensors to detect harmful gases such as carbon monoxide and methane, along with temperature and humidity sensors. The helmet sends real-time data to a monitoring station using wireless technologies such as LoRa and GPS modules. This system allows supervisors to track workers and respond improving worker safety.

4. Smart Helmet with Motion and Fall Detection

Another study introduced a smart helmet integrated with an Inertial Measurement Unit (IMU) to detect worker movement and possible accidents such as falls. The system processes sensor data using algorithms such as sensor fusion and Kalman filtering to improve measurement accuracy. Real-time data transmission allows continuous monitoring of worker movement and orientation, enabling quick emergency response in hazardous workplaces.

5. IoT Helmet with Real-Time Monitoring and Alert System

Recent research has developed an IoT-driven helmet that integrates multiple sensors, wireless communication modules, and alert mechanisms such as buzzers and LEDs. The helmet processes sensor data using a microcontroller and transmits information to a monitoring system or mobile application. In critical situations, emergency alerts can be sent automatically to ensure immediate assistance for workers.

6. Smart Helmet for Worker Tracking and Communication

Some studies also focus on communication and location tracking features in smart helmets. These helmets use GPS and wireless communication technologies to send real-time location data and environmental conditions to supervisors. Such systems enable better coordination, emergency response, and monitoring of workers in hazardous areas such as mining sites and construction zones.

III. PROBLEM STATEMENT

In many industries, workers face dangerous conditions including toxic gases and extreme temperatures. Conventional safety helmets only provide head protection and cannot monitor worker health or environmental hazards.

Many workplace accidents occur because supervisors are unable to monitor workers continuously in real time. Workers may be exposed to dangerous gases, high temperatures, or sudden health problems such as abnormal heart rate or fatigue without immediate detection. In remote or hazardous environments, delays in identifying such situations can lead to serious injuries, health complications, or even loss of life.

IV. BLOCK DIAGRAM

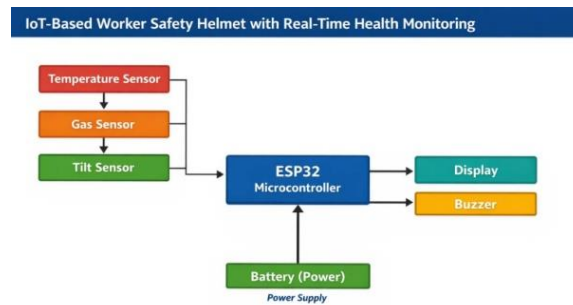

Fig.1: Block diagram of IoT based workers safety helmet system.

V. CIRCUIT DIAGRAM

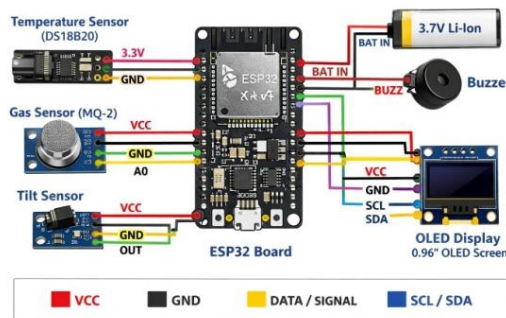

Fig.2: Circuit diagram of sensors connected to ESP32 controller.

VI. FLOW CHART

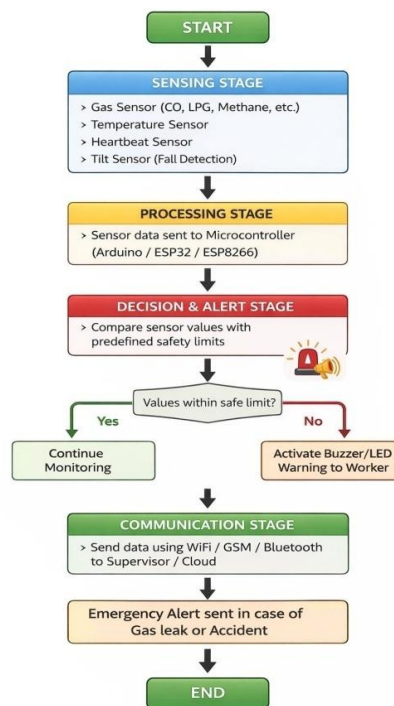

Fig.3: Flowchart showing working process of the system.

VII. SYSTEM ARCHITECTURE OVERVIEW

The architecture consists of sensing layer, control layer, and cloud layer for monitoring worker safety. The system architecture of the IoT-based worker safety helmet consists of sensing units, processing unit, alert system, and communication module that work together to monitor the worker’s health and surrounding environment in real time.

Main Components

Sensors Layer

- Gas Sensor (MQ series) – Detects harmful gases such as CO, LPG, and methane in industrial or mining environments.
- Temperature Sensor – Monitors the worker’s body or ambient temperature.
- Tilt Sensor / Accelerometer – Detects sudden falls or abnormal body movements.

Processing Layer

A microcontroller (Arduino / ESP32 / ESP8266) collects data from all sensors. It processes the sensor readings and compares them with predefined safety limits.

Alert Layer

If abnormal conditions are detected:
 Buzzer and LED indicators are activated to immediately warn the worker.

Communication Layer

- Data is transmitted using Wi-Fi / GSM / Bluetooth to:
- Supervisor’s mobile device
- Control room system
- Cloud monitoring dashboard
- Monitoring & Emergency Response
- Supervisors can monitor worker status in real time.
- In case of gas leakage, fall detection, or abnormal heartbeat, emergency alerts are sent immediately.

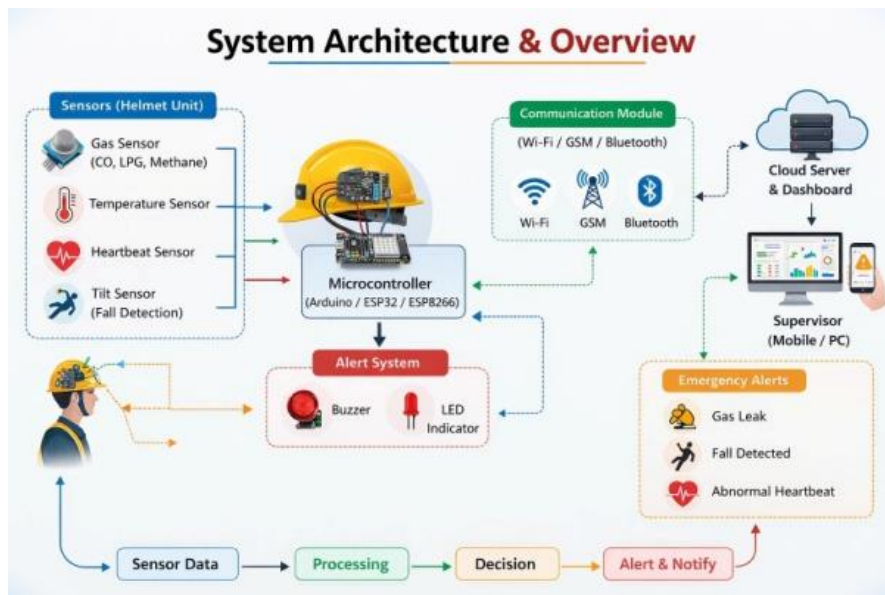

System Overview

The IoT-based worker safety helmet is designed to improve safety for workers in hazardous environments such as mines, construction sites, and industrial plants. The helmet integrates multiple sensors to continuously monitor both environmental conditions and worker health parameters.

The sensors collect real-time data and send it to a microcontroller for processing. The controller evaluates the readings and determines whether they fall within safe operating limits. If any parameter exceeds the threshold, the system triggers immediate alerts through a buzzer or LED to warn the worker.

Simultaneously, the system transmits the data through wireless communication technologies to a supervisor or cloud platform. This allows remote monitoring of worker safety and quick emergency response during accidents or dangerous gas leaks. By combining IoT technology with wearable safety equipment, the system helps reduce workplace accidents and ensures faster rescue actions.

VIII. WORKING PRINCIPLE

The IoT-based workers safety helmet with real-time health monitoring works by continuously monitoring the worker's health and the surrounding environment using various sensors integrated into the helmet. Sensors such as a heart rate sensor, temperature sensor, gas sensor, and motion sensor collect data related to the worker's physical condition and environmental safety. These sensors help detect abnormal conditions like high body temperature, irregular heartbeat, presence of harmful gases, or sudden falls.

The data collected from the sensors is sent to a microcontroller such as Arduino or ESP8266, which processes the information and checks whether the values are within safe limits. If the system detects any abnormal condition, it triggers an alert. The processed data is then transmitted through a wireless communication module like Wi-Fi or GSM to an IoT cloud platform.

Through the IoT platform, supervisors can monitor the worker's health status and environmental conditions in real time using a mobile application or web dashboard. If any unsafe situation occurs, the system immediately sends alerts or notifications, allowing quick response and improving worker safety in hazardous workplaces.

Sensors continuously monitor heart rate, temperature, and gas levels. The ESP32 processes the data and sends it to the IoT cloud platform.

IX. RESULTS AND DISCUSSION

The prototype system successfully monitored worker health parameters and environmental conditions with real-time alerts.

The implementation of the IoT-based worker safety helmet with real-time health monitoring demonstrated effective performance in monitoring both environmental and physiological conditions of workers. The system successfully integrated sensors such as heart rate sensors, temperature sensors, gas sensors, and motion detection modules with a microcontroller and IoT communication module. During testing, the helmet was able to continuously collect health data and environmental parameters and transmit them to a cloud platform or monitoring station in real time. This allowed supervisors to observe workers' health status and surrounding conditions remotely.

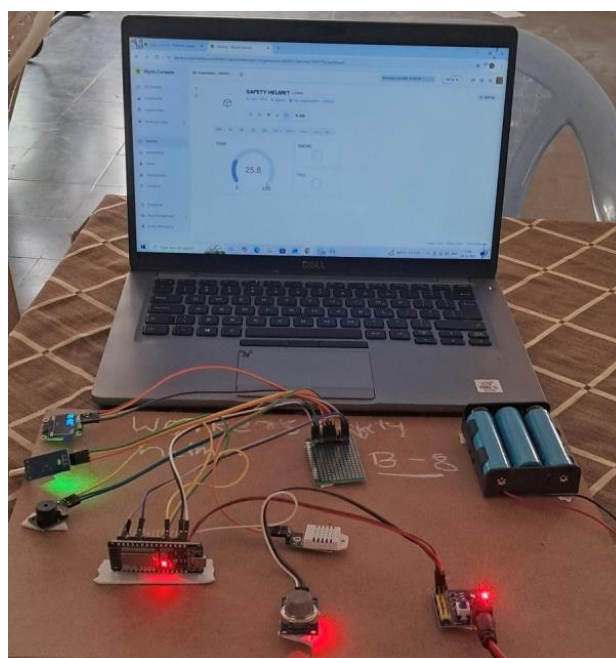

The results showed that the system could detect abnormal conditions such as elevated body temperature, irregular heart rate, or the presence of harmful gases in the environment. Whenever the sensor readings exceeded the predefined threshold values, the system immediately generated alerts and notifications to the monitoring unit. This quick response capability helps prevent accidents and allows timely medical assistance or evacuation if necessary. The GPS module also helped track the worker's location, which is particularly useful in large industrial sites or mining environments.

Another important result observed during testing was the reliability of wireless data transmission. The IoT communication module maintained stable connectivity and ensured that the sensor data was updated continuously on the monitoring dashboard. This real-time data visualization helps supervisors make faster safety decisions and maintain a safer workplace environment. The system also demonstrated low power consumption and compact integration, making it suitable for practical implementation in industrial safety equipment.

Overall, the results indicate that the IoT-based worker safety helmet is an efficient smart safety device that can reduce workplace risks, improve emergency response time, and ensure better health monitoring of workers in hazardous environments

X. CONCLUSION

The IoT-based workers safety helmet enhances industrial safety by providing real-time monitoring and emergency alerts. The IoT-based worker safety helmet with real-time health monitoring improves worker safety by continuously monitoring health parameters and environmental conditions. The system sends real-time data and alerts to supervisors when abnormal situations such as high temperature, irregular heart rate, or harmful gases are detected. This helps in taking quick preventive actions and reducing workplace accidents. Overall, the proposed system provides a smart and effective solution for enhancing safety in hazardous working environments.

XI. FUTURE WORK

Future improvements include GPS tracking, AI-based health prediction, and long-range communication technologies.

Advanced Sensor Integration

Future systems can include more advanced sensors such as gas leakage sensors, body temperature sensors, and fatigue detection sensors to improve worker safety monitoring.

2. AI-Based Health Analysis

Artificial Intelligence and machine learning algorithms can be integrated to analyze health data and predict potential health risks before they become critical.

Improved Battery Management

Developing energy-efficient circuits and long-lasting rechargeable batteries can increase the operational time of the safety helmet.

5G and Advanced Communication Technology

Implementation of 5G technology can enable faster and more reliable real-time data transmission from the helmet to monitoring systems.

GPS-Based Worker Tracking

Integrating GPS modules will allow supervisors to track the exact location of workers in large industrial or mining environments.

Cloud-Based Data Storage and Analysis

Future systems can store collected health and environmental data in cloud platforms for long-term analysis and remote monitoring.

Mobile Application Integration

Development of dedicated mobile applications can allow supervisors and safety managers to monitor workers' health status in real time.

Emergency Alert and Automatic Response System

The helmet can be improved to automatically send emergency alerts to authorities when abnormal health conditions or accidents are detected.

Lightweight and Ergonomic Design

Future helmets can focus on reducing weight and improving comfort so that workers can wear them for long hours without discomfort.

Integration with Smart Industry Systems

The helmet can be integrated with Industry 4.0 smart factory systems to create a complete intelligent worker safety management network.

REFERENCES

- [1]. GuntupalliSireesha, K. Baby Satya Jahnvi, Anusha N., AyushaBaburay, "Smart Helmet Using IoT," International Journal of Engineering Research & Technology (IJERT), 2020.
- [2]. Y. I. Khamis, M. A. Karume, R. Athumani, W. M. Sanya, "An IoT Based Worker Safety Helmet Using Cloud Computing Technology," Tanzania Journal of Engineering and Technology, 2022.
- [3]. HadiSupriyanto, Ismail Rokhim, Vincent Eliezer, "Smart Helmet for Monitoring Construction Workers Using IoT-based ESP32 and LoRa," Indonesian Journal of Computer Science, 2024.
- [4]. Dr. R. Kanagavalli, Pradeep S. V., Santhosh B. T., Dhanush B. C., Akshay R. Bhat, "Smart Mining Helmet: An IoT-Based Automated Safety Monitoring and Worker Protection System," International Journal of Advanced Research in Computer and Communication Engineering, 2025.
- [5]. B. Suresh, K. Vasudevan, V. D. Karthikeyan, et al., "IoT-Driven Smart Helmet: Advancing Safety and Real-Time Monitoring in Mining Operations," International Journal of Electrical Engineering and Technology, 2025.
- [6]. V. Nanda Gopal Reddy, M. Vishnu Vardhan Reddy, AsishPanigrahi, Ch. Bhupathi, "Smart Helmet for Mining Workers Using IoT," International Journal of Environmental Sciences, 2024.
- [7]. Maryam Salim Ali, "IoT-Based Smart Helmet with Integrated Wireless Communication for Hazard Detection and Worker Safety," Spectrum Journal of Innovation, Reforms and Development, 2025.
- [8]. Prof. H. R. Dhananjay, DhanammaDolle, SaipranayTumma, et al., "IoT Based Smart Helmet," International Journal for Research in Applied Science and Engineering Technology (IJRASET), 2025.
- [9]. Rasika Manoj Rewatkar, "The Future of Mining Workers Communication is Seamless Connectivity with IoT Smart Helmet," Journal of IoT-Based Distributed Sensor Networks, 2025.
- [10]. Various Researchers, "Developing an IoT-Enabled Smart Helmet for Worker Safety: Technical Feasibility and Business Model," MDPI Safety Journal, 2024.