

Electric Vehicle's Battery Management System With Charge Monitor And Fire Protection

Suyash S. Hujare¹, Ashutosh S. Shintre², Shridhar S. Dabade³, Rohini U. Madane⁴,
Sanika S. Ghodake⁵, Prof. Dr. R.M.Malkar⁶

Student, Dept. of Electrical Engineering, D.K.T.E Society's Textile and Engineering Institute, Ichalkaranji, India¹⁻⁵

Asst. Prof. Dept. of Electrical Engineering, D.K.T.E Society's Textile and Engineering Institute, Ichalkaranji, India⁶

Abstract: This paper explores the design and implementation of an Electric Vehicle Battery Management System (EV-BMS) with Charge Monitoring and Fire Protection. Developed for Li-ion battery packs in electric vehicles, the system ensures continuous monitoring and protection. Utilizing hardware components such as Li-ion batteries, monitoring systems, microcontrollers, LCD displays and sensors, the EV-BMS facilitates safe charging and proactively prevents accidents. Integrated fire protection utilizes advanced sensors and algorithms to detect and mitigate fire hazards. Through microcontrollers and user-friendly interfaces, the project offers a comprehensive solution, contributing to the safety and efficiency of electric vehicles.

Keywords: EV, BMS, Arduino, Safety.

I. INTRODUCTION

The transition towards electric vehicles (EVs) represents a paradigm shift in the automotive industry, driven by the pursuit of sustainable and eco-friendly transportation solutions. As the adoption of electric vehicles accelerates, the efficient management of electric vehicle battery systems becomes imperative. Our project, the Electric Vehicle Battery Management System with Charge Monitor and Fire Protection, addresses this critical need by integrating advanced technologies to optimize battery performance, enhance user safety, and prolong battery life. The popularity of EVs is fast rising as the globe moves towards a cleaner, more sustainable future. Governments all around the world are granting incentives to stimulate the use of EVs, and numerous automakers are already selling a variety of EV models. An EV typically catches fire because of excessive heating.

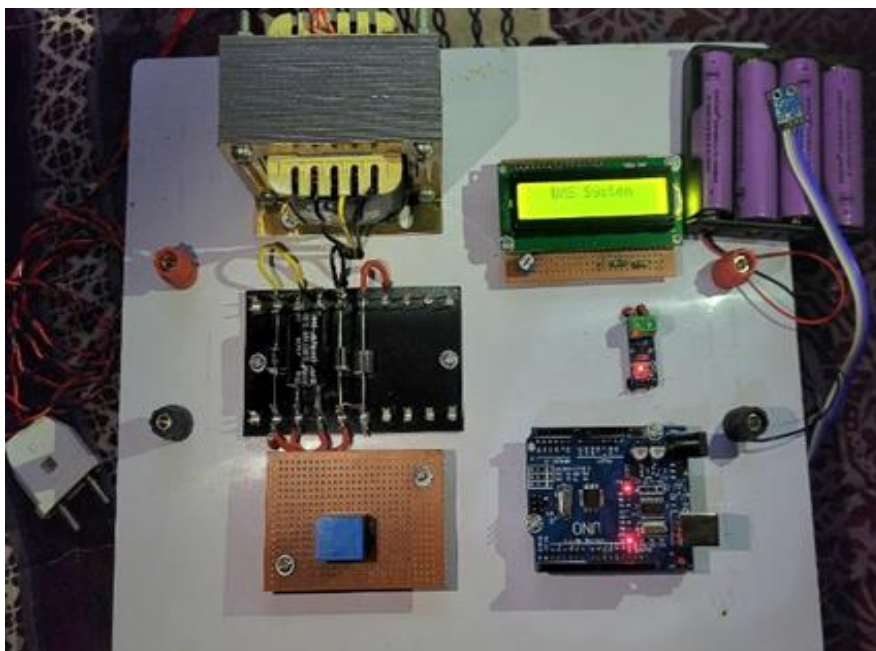

Fig. 1.1 Circuit Module

The system makes use of a li ion Battery, Battery charging and monitor system, LCD Display, current sensor, voltage sensor, temperature sensor to develop this system. The system monitors as well as protects an EV battery at all times. We here develop the system as per a 3S li ion battery. The system we design will not only monitor the battery and charge it safely but also protect it to avoid accidents from occurring. Through the utilization of advanced sensors and algorithms, the system detects potential fire hazards within the battery pack. In the event of a critical condition, the system autonomously initiates a cutoff mechanism, isolating the battery from the load and mitigating the risk of fire.

II. LITERATURE REVIEW

Lithium-ion batteries have emerged as the cornerstone of the electric vehicle (EV) industry, owing to their remarkable energy and power density, extended life cycles, high voltage output, and low self-discharge rates. However, these batteries are not without their challenges. Susceptibility to aging and temperature variations necessitates vigilant management to prevent physical damage, premature aging, and thermal runaways (Bhowmik et al., 2020).

The Battery Management System (BMS) serves as a key element in the optimal functioning of EVs, particularly in safeguarding lithium-ion batteries. An effective BMS is tasked with a multitude of responsibilities, including data acquisition, communication with battery components, user interface feedback, temperature regulation, fault diagnosis and handling, and prolonging battery life.

Charge Monitoring: Charge monitoring stands out as a critical aspect of BMS functionality emphasize the importance of precise voltage and current sensing, alongside state-of-charge estimation algorithms, to optimize charging efficiency and mitigate the risk of overcharging-induced damage. Furthermore, studies by Zhang et al. (2019) and Li et al. (2021) delve into the integration of smart charging strategies and enhance charge monitoring accuracy and adaptability.

Fire Protection: Given the potential hazards associated with lithium-ion batteries, effective fire protection mechanisms are indispensable. Zhang et al. (2018) stress the significance of early fire detection and suppression systems to mitigate fire risks and ensure passenger safety.

III. CASE STUDY

As the global automotive industry transitions towards sustainable mobility solutions, electric vehicles (EVs) have emerged as a promising alternative to traditional internal combustion engine vehicles. However, the efficient management and safety of EV battery systems are critical factors influencing their widespread adoption. This case study delves into the design and implementation of an Electric Vehicle Battery Management System (EV-BMS) with Charge Monitor and Fire Protection, aiming to optimize battery performance, enhance user safety, and extend battery life.

The EV-BMS project focuses on integrating advanced technologies to develop a comprehensive battery management system tailored for electric vehicles. The system comprises hardware and software components carefully selected to monitor, protect, and optimize the EV battery's operation. Key components include lithium-ion batteries, monitoring systems, microcontrollers, LCD displays, and various sensors.

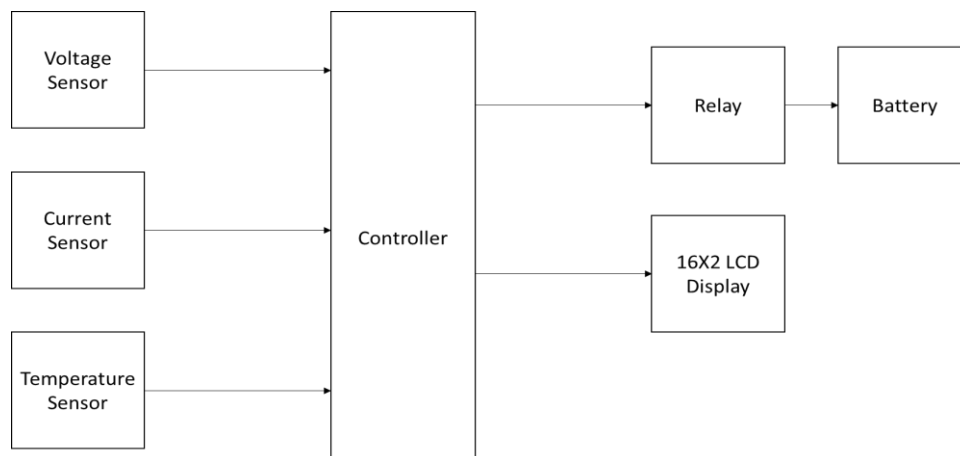

Fig. 3.1 Block Diagram

3.2. Arduino- Microcontroller : ATmega328:



Fig. 3.2. . Arduino UNO

Arduino Uno is an open-source microcontroller board based on the Microchip ATmega328P microcontroller and developed by Arduino.cc. The board is fitted with a set of digital input and analog / output (I / O) pins connected to various expansion boards (shields) and other circuits. The board has 14 Digital pins, 6 Analog pins, and is programmed with Arduino IDE (Integrated Communication Area) on a USB type B. It can be supplied with a USB cable or 9-volt external battery.

3.3 Current sensor:

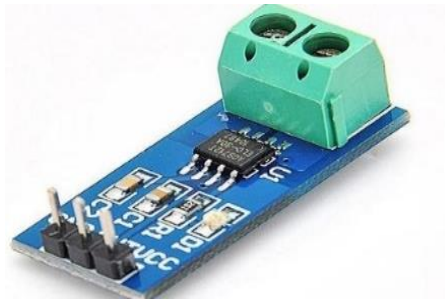

Fig. 3.3 ACS 712 Hall Effect Current Sensor

The load current is 10A hence current sensor having current rating greater than twice the rated current is desired. ACS 712 hall effect current sensor is selected.

3.4.Voltage sensor:

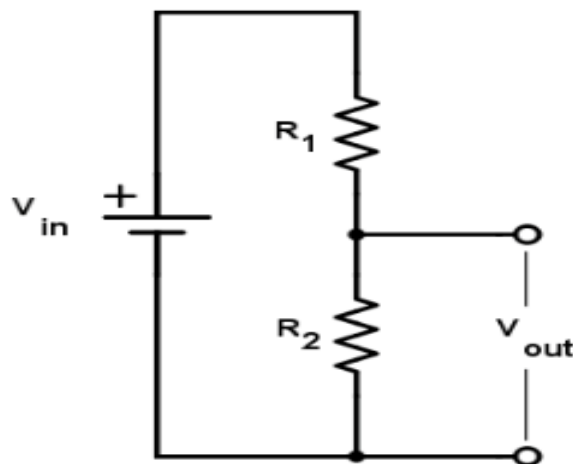

Fig. 3.4 Voltage Divider Circuit

For voltage sensing, a voltage divider arrangement is used as shown in figure. The maximum possible input voltage is considered to be 50V. The Arduino board can withstand maximum of 5V voltage level. Hence voltage divider components should be designed to get output voltage of 5V maximum.

3.5. Temperature sensor:

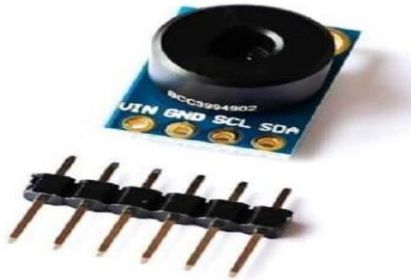

Fig. 3.5 GY906 MLX 90614 IR Sensor

The MLX90614 is an infrared thermometer for non-contact temperature measurements. Both the IR sensitive thermopile detector chip and the signal conditioning ASIC are integrated in the same TO-39 can. Integrated into the MLX90614 are a low noise amplifier, 17-bit ADC and powerful DSP unit thus achieving high accuracy and resolution of the thermometer.

3.6.LCD:-

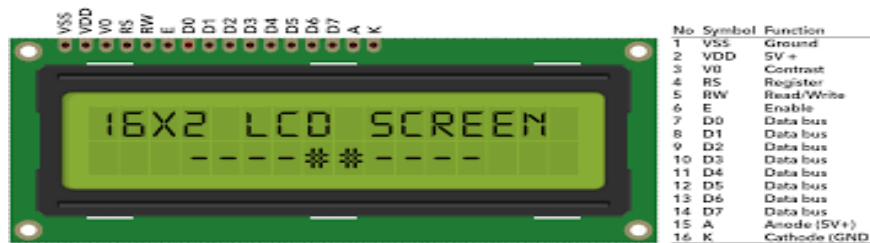

Fig. 3.6 LCD Display

The LCD is a 14 pin device in a row. The voltage Vcc and Vss are provided by +5V and ground respectively while Vee is used for controlling LCD contrast. Variable voltage between Ground and Vcc is used to specify the contrast of the characters on the LCD 16*2 LCD is used to display current, voltage and temperature values.

IV. METHODOLOGY

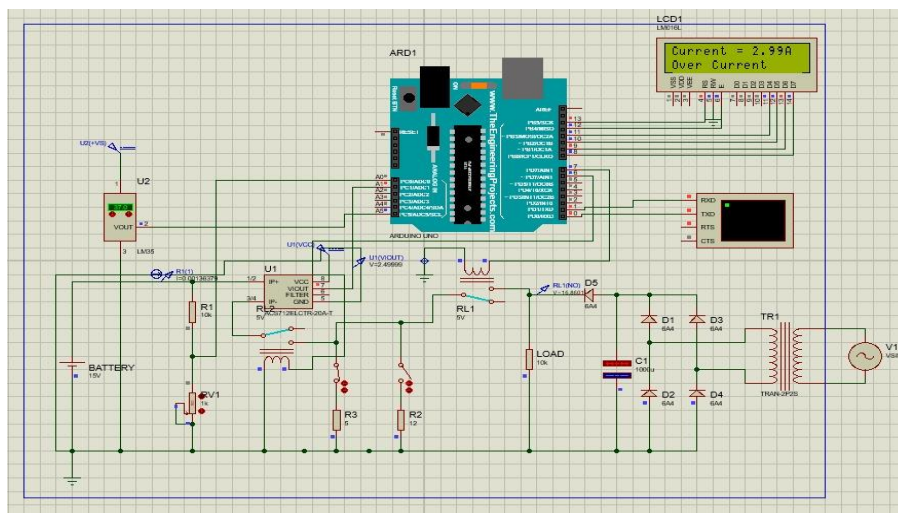

Fig. 4.1 Wiring Diagram

The Electric Vehicle Battery Management System with Charge Monitor, Fire Protection, and Safety Cutoff Mechanism operates through a series of integrated components and sensors, providing comprehensive management, monitoring, and protection for the electric vehicle (EV) battery.

Real-time Monitoring: The system employs the IR temperature sensor, voltage sensor, and current sensor to provide continuous real-time monitoring of the EV battery's crucial parameters.

Safety Cut-off Mechanism: In the event of detected anomalies such as low voltage, overcurrent, or overtemperature, the Arduino-based control system swiftly activates a relay to cut off the load from the battery. This proactive approach prevents potential damage and ensures user safety.

Fire Protection: The inclusion of an IR temperature sensor serves a dual purpose. Not only does it contribute to real-time temperature monitoring, but it also acts as a fire prevention measure. In the presence of unusually high temperatures, the system triggers an immediate response to mitigate the risk of fire incidents.

Charge Control: The charge controller functionality optimizes the charging process for the EV battery. By dynamically adjusting charging parameters based on real-time sensor data, it ensures a safe and efficient charging experience.

V. SIMULATION RESULT

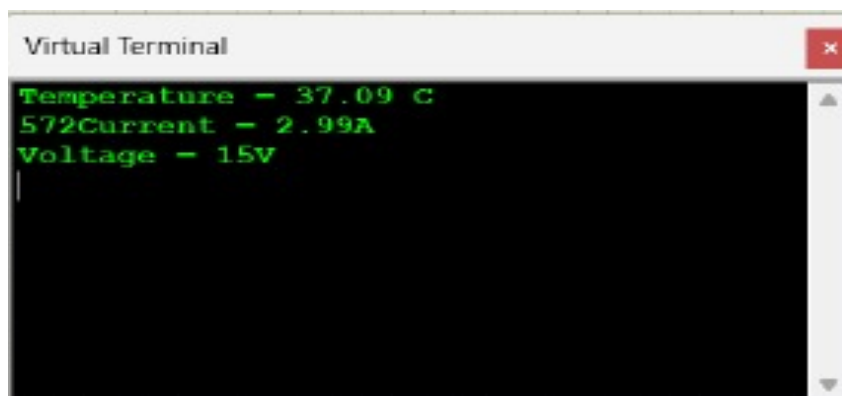

Fig. 5.1 Simulation Results in proteus8

Results:

Voltage Conditions:

Warning: High Voltage: 15V+

Warning :Low Voltage: 12V

Under Voltage: 12 V (relay trips)

Over Voltage: 15V + (relay trips)

If the voltage returns to the normal range (between 12V and 15V), the BMS deactivates the warning messages. If the relay was tripped due to high or low voltage, it resets, allowing the battery to resume normal operation.

Current Conditions:

Warning: Over Current:

Over Current: 2A (relay trips).

Once the current is within the normal range, the BMS deactivates warning messages. If the relay was tripped due to overcurrent, it resets, enabling the battery to resume normal operation.

Temperature conditions:

Warning : Over Temperature

Temperature: 40 .C (relay trips)

If the temperature returns to the normal range (below 40°C), the BMS deactivates the warning messages .If the relay was tripped due to over-temperature, it resets, allowing the battery to resume normal operation.

VI. CONCLUSION

In conclusion, this project is a big step forward in making electric cars better. The Electric Vehicle Battery Management System with Charge Monitor and Fire Protection is like the brain of an electric car's battery. As more people are choosing electric cars, having a smart system to manage and protect the battery is crucial. The system uses different parts like a special battery, a charging and monitoring system, buttons, a screen, and sensors to keep an eye on the electric car's battery all the time. It's designed to be safe and prevent accidents when charging the battery. What makes it stand out is its Fire Protection system, which is like having a smart firefighter inside the battery. It can sense and stop potential fires before they happen, making electric cars even safer. The project also made sure that people can easily use and understand the system. With a simple interface, users can interact with and check on the battery without any hassle.

In summary, this project is making electric cars better and safer by tackling the challenges of managing the battery. It's a smart solution that brings together new ideas, easy use, and extra safety features, pushing electric cars forward in the world of technology and making them more widely accepted.

REFERENCES

- [1]. S. Dhotre, S. S. Gavsane, A. R. Patil, and T. Nadu, International J of Eng & Technology. Innovative science vol. 1, no. 5, pp. 486–490, (2019).
- [2]. .S. A. Mathew, R. Prakash, and P. C. John Int. Conf. Intel. Syst. Des. Appl. ISDA, pp. 189–193, (2020)
- [3]. https://www.researchgate.net/publication/350389634_Battery_Management_Systems_BMS_for_EV_Electric_
- [4]. <https://nevonprojects.com/ev-bms-with-charge-monitor-and-fire-protection/>