

# Automated Guided Vehicle Systems Designing & Development

**Mr.Rahul B. Chandrayan**

Astt. Professor, Department of AIDS, Pune Vidyarthi Griha's College of Engineering, Pune

**Abstract:** In this paper we study design and development of AGVs, here we focuses on the overview on AGVS technology discusses recent technological developments to bring the automation in the Industries, Ports and many more places.

**Keywords:** ATMEGA 328, Software, AGVs, Material handling system, Automation.

## I. INTRODUCTION

As we know MHIA (MATERIAL HANDLING INSTITUE OF AMERICA) focuses on how to handle material with safety, efficiently, with minimum low cost in timely manner, accurately without damage to the material thus we have AGVs to serve us better not only in Industries but also in Ports and other such demanding places. Thus by ensuring the material safety AGVs can also improvise the employee productivity. Employee can up skill themselves and make themselves feature ready.

### a. Problem Statement:

AGVs is leading in today Industries however designing AGVs is not everyone's cup of tea as it require multifold technologies integration to develop the AGVs system. In this paper we are trying to explore the idea of designing and development of AGVs.

### b. Motivation of Project:

The motivation of the project is Industries and labors which always busy in nonproductive tasks such as transporting material from one place to another place and waste the precious time to upgrade themselves and acquire new skills and values to their profiles.

### c. Statistics for Reference:

As per the data available in Google the stats shows for Industry, automotive segment held the largest automated guided vehicle (AGV) market share of USD 5.14 billion in 2023 to USD 7.64 billion by 2028, at a CAGR of 8.25% during the forecast period (2023-2028). The use of AGVs in the automotive industry is being driven by key factors like the increasing after-sales spare parts market, growing levels of vehicle customization, and the need to ensure the availability of diverse parts essential in vehicle assembly.

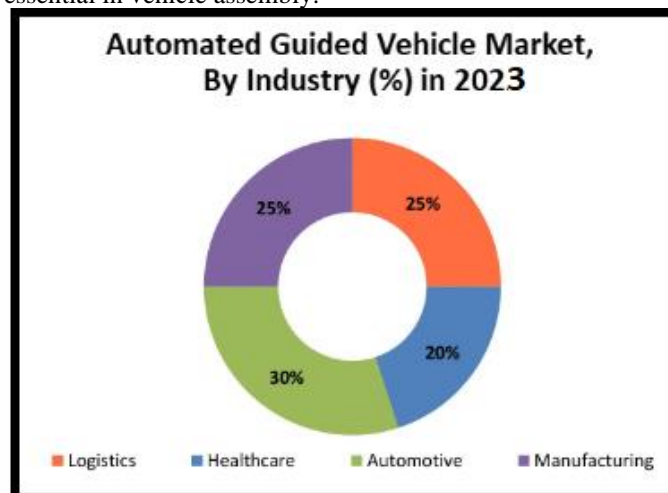

## II. BLOCK DIAGRAM

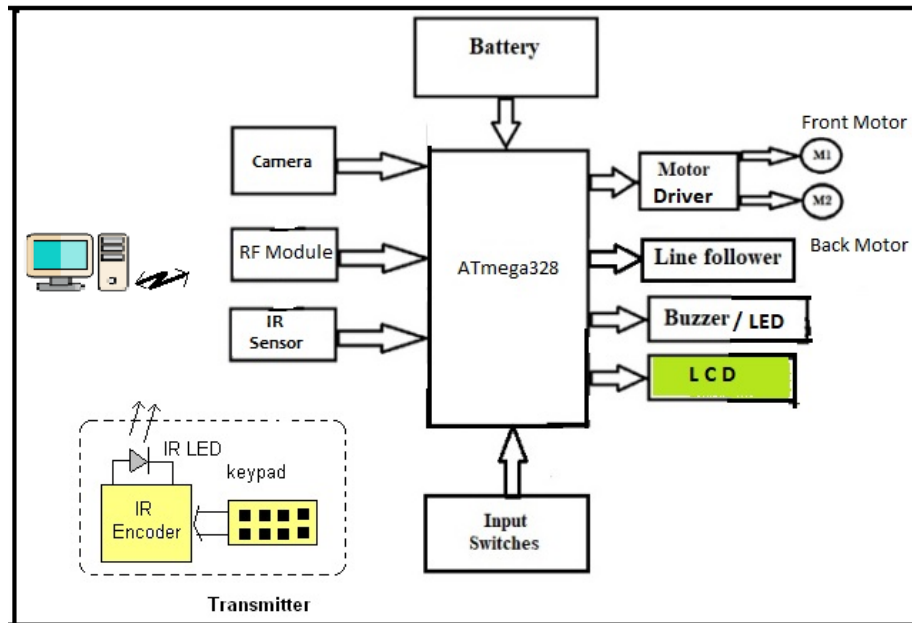

**Basic Block Diagram of AGV**

To understand the above block diagram let us understand each block in details

**Transmitter:-** It is a single chip remote control made up of Encoder chip. it requires no other components. it's a specially programmed micro controller that is used especially for designing IR or RF remote controls. it gives 8 channel interface so we can perform 8 different functions.

**Controlling:-** Includes IR sensor, IR decoder, RF Module, micro controller, LCD, Camera and motor driver chip

**IR Sensor:** – The Infrared Sensor detects IR signal transmitted by IR led of remote control and gives this detected signal to IR decoder

**IR decoder:** – The Infrared decoder is used in pair with IR Encoder chip. it is also specially programmed micro controller for designing IR or RF remote control. it gives 8 outputs as Hi / Low that are given to micro controller

**RF Module:-** RF module can connect to PC through USB to serial converter. It is used for communication between PC and microcontroller. User can send the commands from software's. Microcontroller will then move the vehicle forward, left, right, backward and stop.

**Micro controller(ATMEGE 328):** – it performs following tasks

- Operate the motor in clockwise and anticlockwise directions of individual motors
- Displays on LCD data related to motor speed and direction of respective motors
- Camera is used to capture the real-time images and ensure obstacle free path for AGV to move
- LED Indicators and Buzzer are given to give various indications such as remote sensor connected, motors are running and buzzer are used to indicate any of the alarm situations

**Motor Driver (IC L293D):-** The driver circuit is using L293D IC. It amplifies the output of micro controller and provides sufficient current to the motor to rotate. This is a motor driver IC that uses an H-bridge. You can driver 2 DC motors using a single IC.

**Camera:-** The Camera is interfaced with PC for image acquisition and processing is done with the help of Matlab software. Path can be determined by the user with the help of GUI application.

**LCD:** – it displays different parameters and messages on screen.

**LED indicators:** – it indicates key press form remote control; motor is running, set process in ON etc on different color LEDs

**PC Software:-** Image processing will done in Matlab, so PC is used from which commands has to be received. For this purpose we will use RF module

**Battery:** Battery supply of 12 V is used. Working current of battery is 7Ah. Lead acid battery is used.

**Line follower:** Navigation will be achieved by following black or white lines on the warehouse floor. They are constructed with infrared light emitting diodes coupled with phototransistors. Because the reflective properties of black and white surfaces are different, the sensor will return varying analog values relative to the surface.

**Input switches:** Input switches are provided to give location where material should be delivered.

**Buzzer:** Buzzer is an audible indicator. Working voltage of buzzer is 5V.

### III. PROPOSED FRAMEWORK

In this project we have tried to develop a prototype of an AGV which follows a given path on a flat surface like a path follower. The components we have selected are two dc motors and one freewheel, IR / RF module and Camera. The Camera is interfaced with PC for image acquisition and processing is done with the help of Matlab software. Path can be determined by the user with the help of GUI application. RF module is used for communication between PC and microcontroller User can send the commands from softwares. Microcontroller will then move the vehicle forward, left, right, backward and stop.

#### A. Implementation

The implementation of the AGV can be done with the help of the following blocks following para explores more details above the blocks

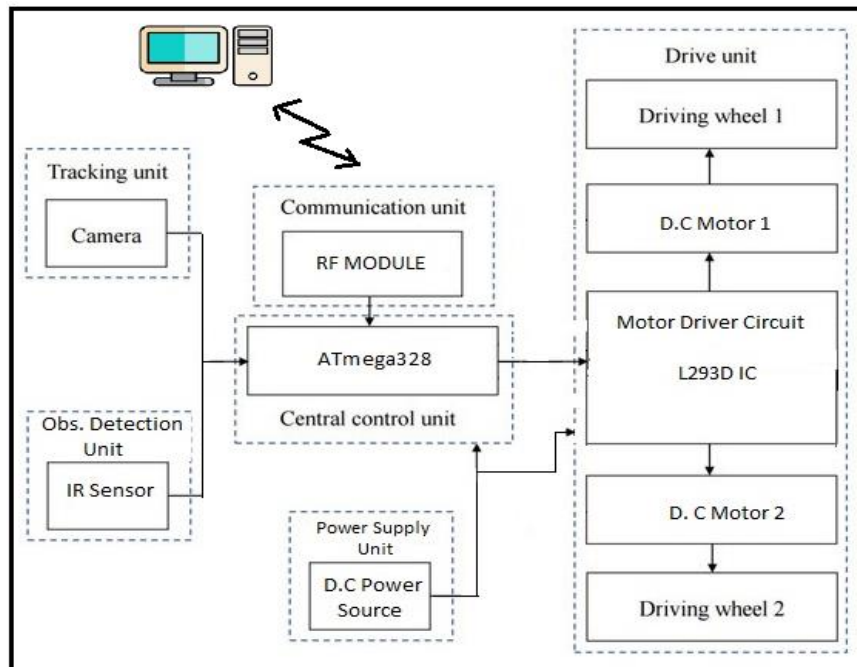

**AGV System Block Diagram**

#### a. Microcontroller(ATMEGA 328)

The AGV is implemented using ATMEGA 328 controller which has a remarkable EPROM compared to other controllers. The controller is being assisted by the ultrasonic sensor that enables the obstacle detection capability in the bot. The AGV can be further promoted to the elevation of automation by its artificial intelligence that is being controlled by Bluetooth / Wi-Fi.

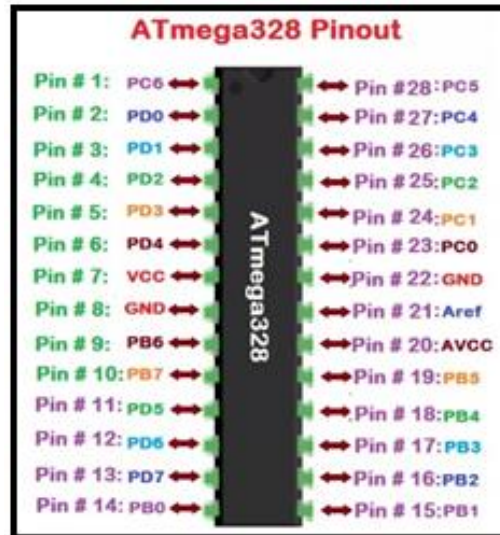

Functions associated with the pins must be known in order to use the device appropriately. ATmega-328 pins are divided into different ports which are given in detail below.

**VCC:** is a digital voltage supply.

**AVCC:** is a supply voltage pin for analog to digital converter.

**GND:** denotes Ground and it has a 0V.

**Port A:** consists of the pins from PA0 to PA7. These pins serve as an analog input to analog to digital converters. If analog to digital converter is not used, port A acts as an eight (8) bit bidirectional input/output port.

**Port B:** consists of the pins from PB0 to PB7. This port is an 8 bit bidirectional port having an internal pull-up resistor.

**Port C:** consists of the pins from PC0 to PC7. The output buffers of port C has symmetrical drive characteristics with source capability as well high sink.

**Port D:** consists of the pins from PD0 to PD7. It is also an 8 bit input/output port having an internal pull-up resistor.

All of the AVR ports are shown in the figure given below.

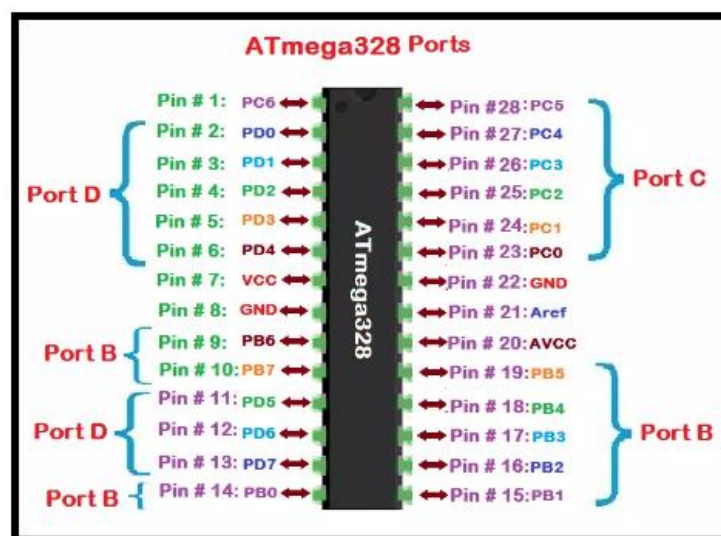

AREF is an analog reference pin for analog to digital converter.

So this was the brief of all the pins in the ATmega328 AVR micro-controller.

### b. Detail Understanding Of Sensors:-

i) **RF MODULE:-** RF module has a low power consumption and high sensitivity. It has integrated data filters. The operating range of RF module is -40 to 85 degrees Celsius. It uses the ISM frequency band and operates at frequency approximately equal to 2.4 GHz. Also it has high accuracy.

RF module is used for communication between PC and microcontroller. User can send the commands from software's. Microcontroller will then move the vehicle forward, left, right, backward and stop.



### ii) IR SENSOR:-

IR sensor is basically used to detect the obstacle. It transmits the signal in one direction and the signal bounces back from the surface of the obstacle and thus the obstacle is detected. It has adjustable range with a POT. The operating range of IR sensor is 5V. Its sensitivity is 30cm which is adjustable.



### iii) Motor Controller:(L293)

Motor controller L293D is used. Motor controllers are devices which regulate the operation of an electric motor. Motor controllers often include a manual or automatic means for starting and stopping the motor, selecting forward or reverse rotation, speeding up or slowing down, and controlling other operational parameters.

L293D is a run of the mill Motor driver or Motor Driver IC which permits DC engine to drive on either course. L293D is a 16-stick IC which can control a lot of two DC engines all the while toward any path. It implies that you can control two DC engine with a solitary L293D IC. Double H-connect Motor Driver incorporated circuit L293 can drive two motors with bi-directional control or 4 motors in single direction.

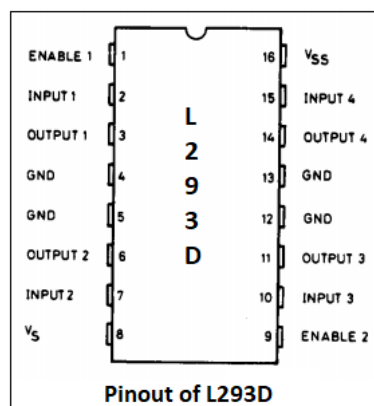

### Pin description:

Pin 1 – When signal is high on this one, the first motor control is enabled

Pin 2 – This is the control pin. A high on this and a low on pin 7 will spin the motor in one direction

Pin 3 – This is where you connect one end of the motor

- Pin 4 – Ground (Connect heat sink too if you need)
- Pin 5 – Ground (Connect heat sink too if you need)
- Pin 6 – Connect other end of the motor with this pin
- Pin 7 – If this pin is high and pin 2 is low, then the motor spins in opposite direction
- Pin 8 – The power supply for the motors
- Pin 16 – The power supply for TTL level (5V)

Other pins are similar and used for bi-directional control of second motor.

If you want both motors to be enabled at all times, then simply connect both the enable pins to Vcc (TTL)

If you want S/W to control enable/disable then connect these pins with the output ports of the microcontroller.

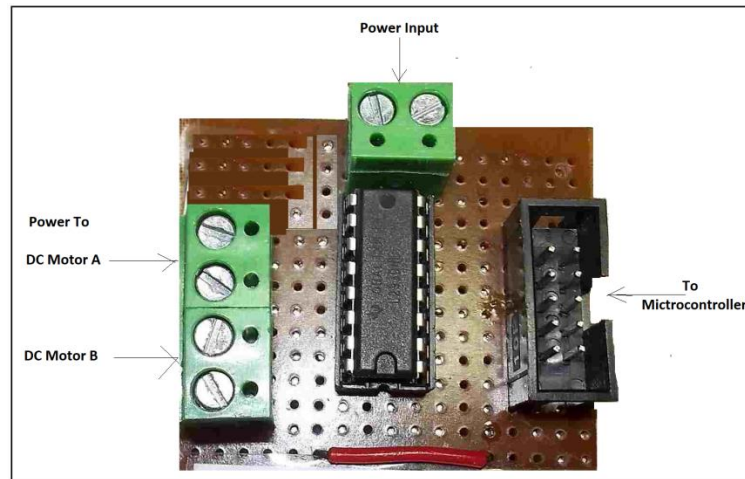

Dual D.C Motor Driver - L293D

## B. Operational Steps and Algorithms

1. Start
2. Microcontroller Initialization
3. USART Initialization
4. Motors Initialization
5. Set the Auto / Manual mode by Remote Keypad
6. Set the speed of DC motor 1 and DC motor 2
7. Give START Command by using Button7

### Auto Mode Working

8. Initialize the USB camera, take image from USB camera
9. Image acquisition
7. Image processing
8. Segmentation
9. Location tracing
10. Send signals to robot assembly
11. Move robot in respective directions

### Manual Mode Working

13. go to step 6 step 7
14. Adjust the speed and direction of motor as per below chart
- 15 Stop Command to stop AGV by using button8 else it will automatically stop if there is any obstacle with the help of IR Sensor.

## C. Working and Operations

There are 8 buttons in remote control that performs following actions.

Sr.No	Remote Button	Functions
1	Button 1	SET Manual Mode
2	Button 2	SET Auto Mode
3	Button 3	SET the "xxx" Rotatation of DC Motor1 in Forward Direction
4	Button 4	SET the "xxx" Rotatation of DC Motor1 in Reverse Direction
5	Button 5	SET the "xxx" Rotatation of DC Motor2 in Forward Direction
6	Button 6	SET the "xxx" Rotatation of DC Motor2 in Reverse Direction
7	Button 7	START Command
8	Button 8	STOP Command
* Note: - "xxx" can be in the range of 0 to 1000 RPM		
<b>Table of Transmitter Keypad Buttons and its Function</b>		

From above table it is clear that first two buttons are used the Set the Auto / Manual mode of AGV. Once Auto Mode is set the Button3 to Button6 gets disable and the AGVs default speed is set at 200 RPM, to start and stop AGV we need to use Button7 and Button8 respectively.

Button 3 to button 6 these four buttons are to rotate motor for different number of rotations. Initially, We need to set the speed of DC motors in forward and reverse direction for DC motor1 with the help of Button3 and Buttom4 respectively. Similarly to set the speed of DC motors in forward and reverse direction for DC motor2 with the help of Button5 and Buttom5 respectively

Once the Button7 is pressed(START command ) is given the AGVs starts moving at the set speed in forward/ reverse direction depending upon button selection however there should be no obstacle in between.

Further by pressing the Button8 (STOP command) gets executed and AGVs stops at the desired place.

In this project we have used IR LED and IR Sensor as transmitter and receiver along with Encoder-Decoder chips for making remote control.

#### IV. HARDWARE RESULTS

An automatic Guided Vehicle can carry weight of material from 1 to 50 Kg. AGV not only follows path effectively but also start and stop according to obstacle, if it comes in path.

#### V. APPLICATIONS

AGV applications are brining automation in many Industries it has been seen that AGV is serving to automate their production processes, handling heavy loads, and automating warehouse operations.

Today's we can connect AGVs via computer systems or iPhone in production environment such that we can Pre-plan it to operate in sync with production flow requirements thereby execute the manufacturing orders on time.

The unmanned operation ensures increasing efficiency while decreasing overhead.

##### A. Automotive & Assembly line

The Assembly Line AGVs and AGCs find their place and replaces in-floor tow lines which were earlier manually operated. However, the safety constraints cannot be neglected and for that purposes with addition of electronic technologies such as AI, ML controlled by Bluetooth, WiFi, LoRa etc., there by using Laser, Cameras, and various other object detection mechanisms. We can have AGVs for Chassis lines, Engine and gear box assembly lines, Final assembly and trim manufacturing processes, JIT( Just-in-time) parts and Pre-production staging

**B. Production & Material handling**

Material handling is day in day out work for the industries and warehouses. Hence the AGVs serves boon in such places replacing the hardcore labor work and saving time. AGVs promotes and provide consistent, just-in-time flow of raw materials to enhance the production capacity i.e. machines operating at maximum capacity. Further automated deliveries of materials can be planned with additional use of software such as SAP, Production planner, MES, ERP etc. Thus we can achieve in-house automation with AGVs for Firstly Moving empty pallets, cans, bottles, containers, labels, layer or slip sheets, lids/caps, wrappers etc. from product line to staging or storage. Secondly loading and unloading of materials from their storage to their actual point of usages.

**C. Warehouse, Distribution centers and Hospital Automation**

Today AGVs is in more demand for hospital and Pharma industries due to high demands of both quality and hygiene. Here, AGVs plays an important role and servers operation such as delivery of dietary/food items, medical/surgical items, pharmaceuticals items, replacement of oxygen cylinder etc. Further, with the involvement of software AGVs can be more users friendly and operated with multiple terminals serving as on demand request approach.

**D. Energy and defense**

The most critical and risky zone where there danger to human life AGV take leads and serves to making by Transporting the material to human at risky & unreachable place such as mining, critical zone such as detection of bomb and retrieval and disposal nuclear plant inspection hence AGV are important subject to develop not only for Nation Interest but for whole mankind.

**VI Advantages and Disadvantages****Advantages of AGVs**

1. Ability to Work in Extreme Climate-Controlled Conditions
2. Reduced Labor Costs
3. Reduced Error Rate
4. Increased Safety
5. Increased Accuracy and Productivity
6. Modularity -Integrated with Production Planning Systems
7. Scalable
8. Works Long Hours
9. Transparency of Operations

**Disadvantages of AGVs**

1. Potentially High Initial Investment
2. Maintenance Costs
3. Not Suitable for Non-repetitive Tasks
4. Decreased Flexibility of Operations - Preplanning is required

**VII. SCOPE AND FORECAST**

AGVs, due to its nature of loading and unloading of items from one place to another with in the premise of industries make it feasible as of now only with battery powered. Thus it needs ample hours of charging time which can be reduced by implementing the solar panels on AGVs.

Further to avoid accidents and free flow of material movement we have electronic solutions such as object detection/obstacle recognition which can be possible with electronic receiver / transmitter systems or sensors. We can also use latest technologies such as 3D vision guiding navigation system.

In conclusion it is said that most of today available AGVs models can be improvise with design issues at manufacturing centers with the deployments of enhanced analytical and simulation models for large AGV systems. These models resolves problems such as large computation times, NP-completeness, congestion, deadlocks and delays in the system and finite planning horizons.

**VII. CONCLUSION**

The design, development and onsite deployment of AGVs becomes ease with the utilization of modern design tools, availability of controllers, communication technologies and electrical equipment. However to implement the end to end solutions bring new challenges particularly when the load size is too heavy.



Thus to bring the autonomy in the industries we need to significantly promote and develop easily deployable solution for Industries and Warehouses.

### REFERENCES

- [1] K. Schilling, M. Mellado-Arteche, J. Garbajosa and R. Mayerhofer, "Design of flexible Autonomous transport robots for industrial production", in Proc. IEEE Int.Symp. Industrial Electronics (ISIE'97), vol. 3, New York, NY, 1997, pp. 791-796.
- [2] Schulze, L.; Wüllner, A., "The Approach of Automated Guided Vehicle Systems", presented at 2006 IEEE International Conference on Service Operations, Logistics and Informatics, 21.-23.06.2006, Shanghai, China.
- [3] Hau- Shiue Juang and Kai-Yew Lum, "Design and control of a two wheel self-balancing robot using the arduino microcontroller board", IEEE International Conference on Controls and Automation, China, June 2013
- [4] Guo F., Yuan X., Yu D., Yuan K., "Research on Key Technology of AGVs", Journal of University of Science and Technology Beijing, 1999 (in Chinese).
- [5] Y. Tanaka, T. Nishi and M. Inuiguchi, "Dynamic Optimization of simultaneous dispatching and conflict- free routing for automated guided vehicles", J. Adv. Mech. Des., Syst., Manuf., vol.4, no.3, pp. 701-715, 2010.
- [6] S. G. M. Hossain , Hasnats Jamil ,Muhammad Yakut Ali ,Md. Zahurul Haq, "Automated guided vehicles for industrial logistics Development of intelligent prototypes using appropriate technology",19 April ,2010, The 2nd International Conference on Computer and Automation Engineering (ICCAE).
- [7] Schulze, L., Lucas, M., "Logistics and Automation State of the Art and Trends in Europe", presented at Greater China Supply Chain and Logistics Forum and Academic Conference 2005, 30.10.2005, Nanjing, China.
- [8] J. Sankari, R. Imtiaz, "Automated Guided Vehicle (AGV) for industrial sector", 03 November, 2016, 10th International Conference on Intelligent Systems and Control (ISCO).