

# SMART Water Metering System

**Mr.Rahul Chandrayan**

Research Student, Department of Electronic and Communication Engineering, Abha Gaikwad-Patil College of Engineering, RTM – Nagpur University.

**Abstract:** This paper presents and modern approach for water metering it uses a real time approach of monitoring the standard water quality parameters and store them for further analysis and reporting purposes. Considering the ever-increasing demand of water and the purity it become essential to develop the SMART System which can provide the real time data for decision making purposes at various ETP, WTP and STP plants. The proposed solution is one of the solutions which uses today's technology IoT to resolve the above problems. This paper directs by taking initiative steps for presenting the water level and quality monitoring. The approach here is to collect the real time data from various sensors (water flow sensor, pH sensor, water control valve and water level sensor) and can further be monitored on software, website or mobile devices. After capturing the data from the various sensors, the data can be processed with microcontroller and stored in database and further with the help of wireless module it can be sent to the cloud environment from where it can be accessed 24x7 anywhere anytime via internet.

**Keywords:** Real time monitoring, water quality monitoring, IoT, cloud environment, Ph sensor, water flow sensor, water level sensor, Microcontroller, Software, Website, Wireless module

## I. INTRODUCTION

Water pollution is one most important component environment pollution. Polluted water causes different kinds of problems not only to human beings but also to animals and plants. Urbanization and industrialization are increasing enormously with the proportionate rate of population growth. Pollution of water can cause severe damage to our health, impair the fertility of the land, and harm the aquatic life.

Industrial waste materials are one of the prime causes of water pollution. Textile dyeing is the second severest cause for water pollution globally, and the fashion industry produces 20% of the world's wastewater. In the manufacturing of clothing and household appliances, manufacturers' extensive water consumption and sanitation activities pollute soil and groundwater which negatively impact the environment, affecting ecosystems, and animal and human food chains.

For examining the water quality manual efforts were required for testing. Such approaches take longer time and today no longer to be considered efficient. Thus, to resolve the above issue we have proposed the following model which monitors the real time water quality and ensures the quality, salinity and purity of water.

### A. Internet of Things (IoT)

Over the past few years, IoT has become one of the most important technologies of the 21st century. As per the definition of Wikipedia IoT is "The Internet of things describes physical objects with sensors, processing ability, software and other technologies that connect and exchange data with other devices and systems over the Internet or other communications networks." That is, we can say that the IoT brings internet connectivity, data processing and analytics to the world of physical objects. The physical objects can be sensor, devices or even machines etc. Also, with IoT it became easier to scale up or scale down the solutions as per the need and requirement of hour. Almost all the sectors may it be industries, healthcare, energy, transportation, agriculture, nanotechnology, mining, robotics etc uses IoT applications to meet the various present and future demands. Thus, we can conclude that IoT has abundant power and it can have capacity to bring the value-added solutions to almost all the sectors and segments in the industries.

### B. Problem statement

There are number of existing water treatment solutions but some of them are only able to detect the purity and followed with process such as Chlorinating is usually used to protect micro-organisms. Further this approach is unable to detect the dissolved contaminants such as chemicals. Thus, this approach has limitations and is not safe since it is not addressing towards the detection of possible parameters such as pH, temperature, and conductivity.

Thus, our model will help curb water borne diseases by developing a real-time online water quality monitoring system. With this model we can detect all the possible water quality parameters and availability of water in water tank.

### C. Motivation of project

Water Pollution is a major universal problem. It has been surveyed that water pollution is the leading cause of deaths and diseases worldwide. The water prone diseases are reaching to new levels and most importantly, the availability of drinking water is some of the prominent challenges the industry is facing today.

#### Statistics for Reference:

The records show that more than 14,000 people die daily worldwide. In India predictable 580 people die of water pollution related illness every day. In many developing countries, dirty or contaminated water is being used for drinking without any proper former treatment. The main reason for this happening is the unawareness among public and administration and the lack of water quality monitoring system which creates serious health related issues. Also, natural phenomena also change the quality of water and results into contamination of water. The most important aspect for all living organisms is water and it is necessary to preserve water. So, water quality monitoring is fundamental step for protection of water resources. Designing this system will help to monitor the quality of water based on information sensed by the sensors submerged in water tank in order to know the various parameters of water. Using different sensors, this system can collect various parameters from water, such as temperature, pH, water level, water flow, sludge density, amount of chemicals, pressure, and flow rates from various sensors and sends the data to the cloud.

## II. BLOCK DIAGRAM

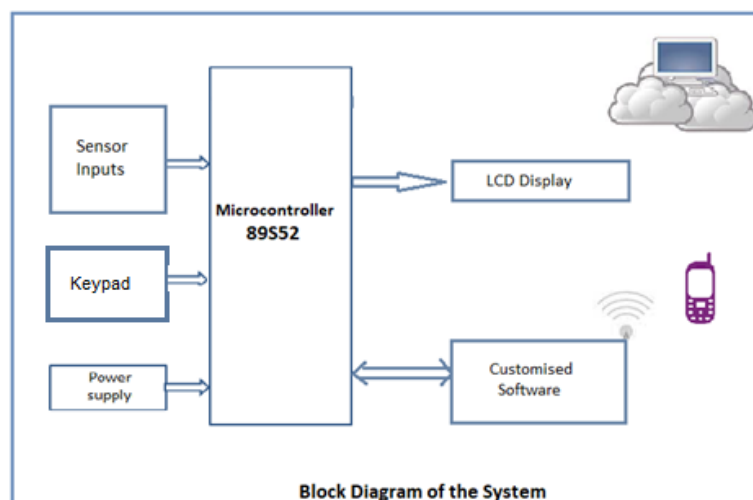

## III. LITERATURE SURVEY

**YEAR** : 2015 IEEE

**PAPER NAME:** Design of water management system

**AUTHOR** : F N tambi, C P Kruger, B J Silva, G P Hancke

**DESCRIPTION:** The system consists of 3 wireless sensor sub system All communicate with each other wirelessly and send information to gateway connected to a computer which hosts the GUI.

**LIMITATION:** Due to wireless transfer of data sometimes delivery of data is not ensured. There are chances of loss of data.

**YEAR** : 2016 IEEE

**PAPER NAME:** Smart water management using IoT

**AUTHOR** : Sayali Wadekar, Vinayak Vakare, Ram,Ratan Prajapati

**DESCRIPTION:** Water level sensor will provide the level of water present in the water tank and according to the level of water, water motor will automatically turn ON and OFF. Data is displayed on android application.

**LIMITATION:** No quality monitoring is performed, so even if water is available in tank, without performing quality check, water will be supplied. The application needs to be downloaded and updated from time to time.

**YEAR** : 2017 IJRSET**PAPER NAME:** An IoT based model for smart water distribution with quality monitoring**AUTHOR** : Joy Shah**DESCRIPTION:** The paper focuses on water distribution using water flow sensor and water control valve will help in even distribution of water and provide adequate amount of water.**LIMITATION:** The model does not use water level sensor, so the availability of water in the tank will not be known. People will not be aware of unavailability of water.**YEAR** : 2018, International Journal of Innovative Science and Research Technology**PAPER NAME:** IOT Based Real time water Monitoring System for Smart City**AUTHOR** : Rupalir Shevale, Shweta Karad, Ashwini Kardile, Maryam Merchant, Vijeyata Mishra**DESCRIPTION:** The paper focuses on use of cloud for storing the sensor data. It also uses water level sensor which will give real time information about the level of water in the water tank further It displays data on website, so using website over application ensures accessing the data more rapidly and from anywhere.**LIMITATION:** This model does not include the details such as metering of water volume consumption which helps to creates awareness of water conservation and help in finding the consumption costing.

By considering the limitation of previous models of water management systems, our model overcomes the drawbacks as it captures the details such as water flow, quality, level and temperature details we can present the sensor limits with the help of keyboard and for this we have used LED display to indicate the setting values and also used to display the output from the controller includes various parameters of interest from the sensors. Further we can send the SMS to the respective stakeholders for any of the predefined alerts via software unit. The software with predefined interval can sync the data with cloud platform. Also it has been noted that unlike previous model referred in literature survey it does not require continuous internet connectivity and the system can be operated Offline as well as Online Mode.

The system can have adjustable sync time with cloud so that it can timely update the data on to the cloud so that the system Users can get the real time status. The system can generate various customised report such as Consumption, flow rate, consumption billing, and history of readings from the meter so that consumption trends can be analysed. The system facilitated to set the limits for consumption as per the requirements from the software itself with this facility in software's allow tracking and manage of multiple hardware units at distinct location and collaboratively integrate the different location data from the same software unit respectively.

#### IV. PROPOSED FRAMEWORK

In this proposed block diagram consist of several sensors (temperature, Ph, water flow and water level) is connected to core controller. The core controller are accessing the sensor values and processing them to transfer the data through internet. AT 89S52I is used as a core controller. The sensor data can be viewed on the software using cloud or mobile apps. Keyboard inputs are used to set/reset the sensor values as per the requirements manually further we can set the sensor limits to control the level or flow with the help of software. The output can be seen with the help of LCD display which is attached to hardware also it can be seen from remote locations on software or mobile app.

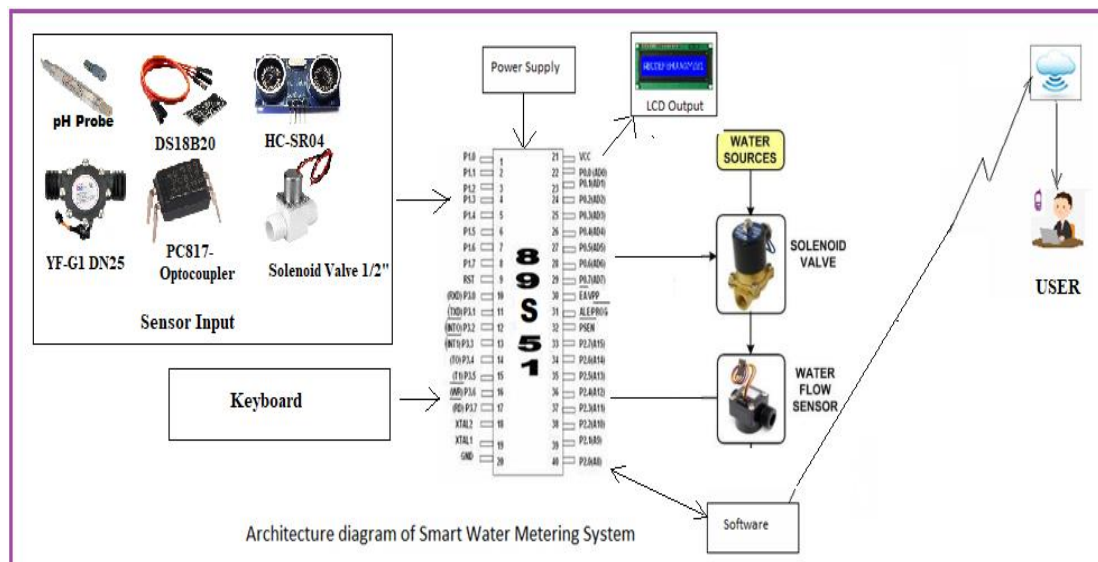

### A. Water quality sensor

The pH meter (pH probe) is used for the quality check if water is safe for drinking. A balanced pH level is very important for human health; it should be approximately equal to 7. pH measurement range from 0 to 14. It gives a Single reading and continuous reading modes.



**pH Probe**

### B. Temperature sensor

A device which gives temperature measurement as an electrical signal is called as Temperature sensor. The DS18B20 is a 1-wire programmable Temperature sensor from maxim integrated. It is widely used to measure temperature in hard environments like in chemical solutions, mines or soil etc. The constriction of the sensor is rugged and also can be purchased with a waterproof option making the mounting process easy. It can measure a wide range of temperature from  $-55^{\circ}\text{C}$  to  $+125^{\circ}$  with a decent accuracy of  $\pm 5^{\circ}\text{C}$ .



**DS18B20**

### C. Water level sensor (HC-SR04-Ultrasonic sensor module)

Water level sensor will help us decide if we have enough quantity of water to be supplied. An ultrasonic wave is triggered from the sensor and distance to target is determined by calculating the time required after the echo is returned. The HC-SR04 ultrasonic distance sensor. This is economical sensor provides 2cm to 400cm (1" - 13ft) within a 30 degree cone of non-contact measurement functionality with a ranging accuracy that can reach up to 3mm. Each HC-SR04 module includes an ultrasonic transmitter, a receiver and a control circuit.



**HC-SR04**

### D. Water flow sensor

For continues, water flow rate measurement YF-G1 DN25 can be used. YF-G1 DN25 is 1 inch Water flow sensor used for flow measurement it consists of a plastic valve body, a water rotor, and a hall-effect sensor. It has operating temperature range of  $-20^{\circ}\text{C}$  -  $85^{\circ}\text{C}$  which is wide enough for our application to operate successfully. When water flows through the rotor, rotor rolls. Its speed changes with different rate of flow. The hall-effect sensor outputs the corresponding pulse signal. This one is suitable to detect flow in water dispenser or coffee machine.



**YF-G1 DN25**

**E. Solenoid valve**

A solenoid valve is used as a water controlling valve, it is a simple electromagnetic device that converts electrical energy directly into linear mechanical motion. A Solenoid Valve 1/2" with DC 3.6-6V Water Control Electric Pulse (Bistable) is used. The valve is normally closed when there is no pulse applied, it opens if a positive pulse is applied and gets closed again when there is a negative pulse. The input and output thread size of the valve is G1/2in. This is mainly used in water purification equipment, engineering water control system, integration faucet. This electric pulse solenoid valve has fine workmanship, stable and long life and it is not easy to break it down.



Solenoid Valve 1/2"

**F. LCD**

LCD (Liquid Crystal Display) screen is an electronic display module and finds a wide range of applications. A 16×21 LCD display is a very basic module preferred over seven segment and other multi segment LCDs. The reason being LCDs are economically easily programmable and have no limitations of displaying special and even custom character animation. The data of ASCII value of the data to be displayed on the LCD. This type of LCD is connected to uC using parallel 8 bit or 4 bits line.

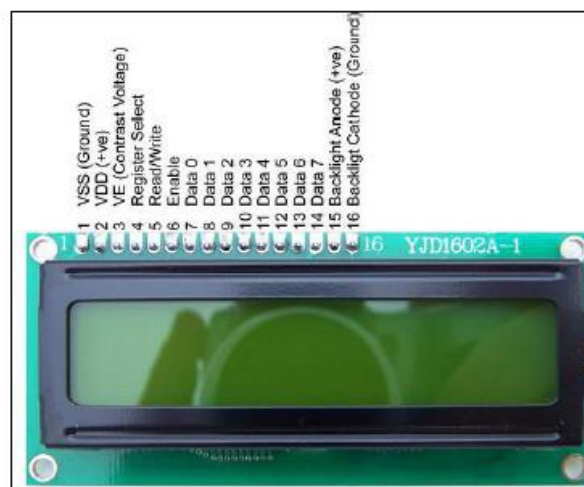

LCD

**G. PC817 Optocoupler**

PC817 is an optoisolator consists of an infrared diode and phototransistor. They are coupled together optically. In electric circuits, we use mostly filters to remove noise. The Electrical signal transfers between an input and an output side optically without any physical connection between both sides.



PC817 Optocoupler

## H. Software and Cloud Platform

The sensors are controlled by the 89S52 controller which is connected to the software unit via MODBUS protocol. The data collected from the software is updated on cloud via MQTT protocol with fixed interval as per the setting given in software. Further the data can be accessed to the end user from cloud at any point of time on mobile as well as on software at any remote location.

## I. Communication protocols

i) Modbus is a serial communication protocol developed by Modicon published by Modicon® in 1979 for use with its programmable logic controllers (PLCs). In simple terms, it is a method used for transmitting information over serial lines between electronic devices.

The device requesting the information is called the Modbus Client and the devices supplying information are Modbus Servers. In a standard Modbus network, there is one Client and up to 247 Servers, each with a unique Server Address from 1 to 247. The Client can also write information to the Servers.

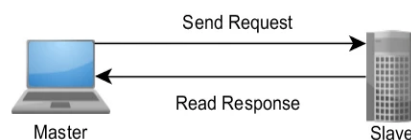

*A Master-Slave Networking Relationship*

ii) MQTT – Message Queuing Telemetry Transport

MQTT (Message Queuing Telemetry Transport) is a messaging protocol for restricted low-bandwidth networks and extremely high-latency IoT devices. Since Message Queuing Telemetry Transport is specialized for low-bandwidth, high-latency environments, it is an ideal protocol for machine-to-machine (M2M) communication.

MQTT works on the publisher / subscriber principle and is operated via a central broker. This means that the sender and receiver have no direct connection. The data sources report their data via a publish and all recipients with interest in certain messages (“marked by the topic”) get the data delivered because they have registered as subscribers.

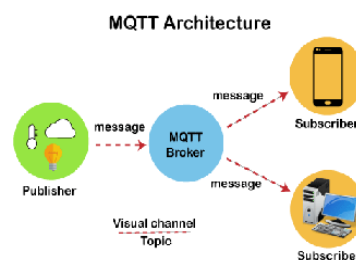

## J. Microcontroller

### AT89S52 Microcontroller

It is an 8-bit, low power, high performance, CMOS technology-based microcontroller with having an operating frequency range between 0 to 33MHz. The chip can work in two power selectable operating modes.

This device offers 32 GPIO pins which can be used as digital input-output pins or also some pins can be used for alternate functions. Which we will use for connecting sensors-pH sensor, ultrasonic sensor, Water flow sensor, temperature sensor and solenoid valves, and can be used as outputs, a USB connection and a power jack is also present.

**Features and Specifications**

Features and Peripherals	Availability
Architecture	8-bit PIC
Pin Count	40
RAM	256 Bytes
EEPROM/HEF	No
Program Memory	8 KiloBytes
CPU speed	33 MHz
Number of Comparators	2
Number of Programmable I/O pins	32
Window Watchdog Timer	No
External Oscillator Frequency	23 MHz (max)
Number of 16-bit Timers	3
Program Memory Type	Flash
UART module	1
Power-off Flag	Yes
Dual Data Pointer	Yes
Operating Voltage	4V – 5.5 V
Operating Temperature	-55°C – 125°C

**Some of the eminent detailed features are listed below:**

- It is a high-performance CMOS microcontroller with Flash Technology
- The unit operates at a wide range of 4 – 5.5 volts, so it is a low power IC.
- The device supports In-system Programming both page and byte mode for the Flash memory.
- The operational frequency is up to 33MHz but can be altered for saving energy.
- The module has a quick programming time with 10,000 read/write cycles.
- The Random Access memory is organized in 256×8 bits.
- The serial communication takes place through a full duplex UART module.
- It comes with a reset option, three 16-bit timers and eight interrupts.
- AT89S52 has two power modes, i.e., idle mode in which stops processing unit stops while other peripheral keep working and power-down mode that halts oscillator and other functions and save RAM contents.
- Watchdog timer to work and wake the device up from sleep mode and can be activated or deactivated through programming

**K. Node red**

Node-RED is Open-Source software by IBM and is a graphical programming language used for building connected objects. For wiring all the things together in IoT Node-RED is used. When binder functions are programmed with Node-RED they are presented in the form of bricks. Thus the data stream passes from one treatment to the other (from one function to the other). It is easy to use flow-based programming environment that helps IoT developers interact with APIs and different services. A Node-RED flow works by passing messages between the nodes.

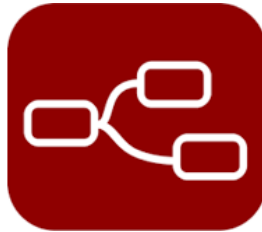
**V. MATHEMATICAL MODEL**

Let S be a Water Metering System such that

**S= {I, O, F}**

I= set of inputs

O= set of outputs

F= set of functions

**Input: Sensor Data**

I= {I1, I2, I3, I4}

I1= Water quality sensor

I2= Temperature sensor

I3= Water Flow sensor

I4= Water level sensor

**Function:**

F= {F1, F2, F3, F4}

F1= get sensor data

F2= store data in local software

F3=update and sync sensor data to cloud platform

F4= display data on website and mobile app

**Output:**

O= {O1, O2, O3, O4}

O1= if water is contaminated the outlet of water tank will be closed

O2=mobile SMS/ alerts to the customer

O3=Sync data to cloud platform

O4=show data on software

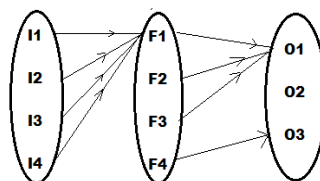

Venn Diagram



## VI. CONCLUSION

In our proposed system, water quality monitoring along with metering is presented. The proposed system is created with the use of different sensors, Microcontroller 89S51 which communicate with the PC and stores the real time data captured from the various sensor units, further the initial level setting can be done from PC software so that it can set the required limits for the respective sensors. Once the data get captured locally the data can be pushed on the cloud server for storage via internet thus it reduces the internet usage and dependencies further the system can be operated in both Online/ Off line mode. Alerts can be generated and shared with the respective stakeholder via SMS. This enables the stakeholders to take precautionary steps there by getting the continuous feedback and updates from the system. Further, the system can have adjustable sync time with cloud so that it can timely update the data on to the cloud so that the system Users can get the real time status.

The system can generate various customised report such as Consumption, flow rate, consumption billing, and history of readings from the meter so that consumption trends can be analysed. The software system design in such a way that it can be easily scale up and scale down and we can add multiple hardware units for sensing the real time data from multiple location in real time. The proposed model can be implemented as a part of the smart city as well as in ETP and WTP plants.

## VII. ACKNOWLEDGMENT

It gives us great pleasure in presenting the preliminary project report on SMART Water Metering System I express my heartily gratitude towards **Prof. Rohini Pochhi**, HoD and **Prof. Rahul Dhutur**, ECE for her guidance to understand the work conceptually and also for her constant encouragement to complete this Project work on "SMART Water Metering System". With deep sense of gratitude, I would like to thank to our Principal Dr. Prashant Kadu and Management of the collage for providing all necessary facilities and their constant encouragement and support.

## REFERENCES

- [1]. Sayali Wadekar, Vinayak Vakare, Ramaratan Prajapati, "Smart water management using IoT", IEEE pp: 978-15090, 2016. <http://ieeexplore.ieee.org/document/7993425/>.
- [2]. F Ntambi, CP Kruger, BJ Silva and GP Hancke, "Design of a water management system", IEEE pp. 97814799, 2015. <http://ieeexplore.ieee.org/iel7/7318235/7331857/07332012.pdf>.
- [3]. N Vijaykumar, R Ramya, "The real time monitoring of water quality in IoT environment", IEEE pp: 978-1-47996818, 2015. [https://www.ijirset.com/upload/2016/march/246\\_The\\_new.pdf](https://www.ijirset.com/upload/2016/march/246_The_new.pdf).
- [4]. Joy Shah, An Internet of Things Based Model for Smart Water Distribution with Quality Monitoring, International Journal Of Innovative Research In Science, Engineering And Technology, 2017. [https://www.ijirset.com/upload/2017/march/74\\_An\\_Internet.pdf](https://www.ijirset.com/upload/2017/march/74_An_Internet.pdf).
- [5]. Patawala Amatulla, Bansode Navnath, Bhong Yogesh, "IOT Based Water Management System for Smart City", International Journal Of Advance Research, Ideas And Innovations In Technology, 2017. <https://www.ijariit.com/manuscripts/v3i2/V3I2-1252.pdf>.
- [6]. Khaled Reza, S.M., Shah Ahsanuzzaman Md. Tariq, S.M.Mohsin Reza (2010), 'Microcontroller Based Automated Water Level Sensing and Controlling: Design and Implementation Issue'. Proceedings of the World Congress on Engineering and Computer Science, pp 220-224.
- [7]. Venkata Naga Rohit Gunturi (2013), 'Micro Controller Based Automatic Plant Irrigation System', International Journal of Advancements in Research & Technology, Vol. 2, Iss. 4, ISSN 2278-7763
- [8]. S. Pallavi, "Internet of Things: Architectures, Protocols, and Applications," Journal of Electrical and Computer Engineering, pp. 1-26, 2017.