



Simulation and Modeling of High Efficiency Inverters for Solar PV Cell Applications

Bikash Kumar Mohanty¹, Dr.Shafali Jain², Mr.Mithlesh Gautam³

¹M.Tech* – Power Electronics, Truba College of Science and Technology, Bhopal, M.P

²Professor & Head of Dept., Electrical & Electronics Engineering, TIEIT, Bhopal, M.P

³Assistant Professor, Electrical & Electronics Engineering, TCST, Bhopal, M.P

Abstract: This paper presents modeling and simulation of an impartial Photo-Voltaic (PV) system with upgraded multilevel Inverter using MATLAB/SIMULINK. The filtration of lower order harmonics is a challenging issue. So to reduce the harmonic contents, the level of the output voltage is increased up to 25 levels by proper arrangement of multilevel inverter with reduced number of switches. The model includes a 25 level inverter which claims that the total harmonic distortion (THD) reduced to approximately 3%. The proposed 25 level inverter uses only 12 numbers of switches which is very less than that of diode clamped, capacitor clamped and cascaded H-Bridge multilevel inverter (MLI). The comparative analysis of THD between the two system discussed in this paper says that the THD is increased by introducing the DC-DC converter which is approximately found to be 12% but it is less as compared to the other conventional multilevel inverters used for PV system . It also reduces the rating of the PV cell. The rating of the PV cell is higher in the system when the dc-dc converter is not included

Keywords: Boost Converter, MPP, MPPT, MLI, PV System, THD

1. INTRODUCTION

Global energy demands are increasing at a rapid rate. This has led to high consumption of fossil fuels with negative environmental consequences including global warming, acid rain and the depletion of the ozone layer. The diversification of energy resources is crucial in order to overcome the negative impacts of fossil fuel energy technologies that threaten the ecological stability of the earth. Furthermore, rising fuel prices and the growing scarcity of fossil fuel may have negative economic and political effects on many countries in the near future. The improvement of energy efficiency and the effective use of renewable energy sources are key to sustainable development.

A possible solution to this crisis lies in renewable energy systems. Various renewable energy technologies have been developed, which are reliable and cost competitive compared with conventional power generation. The cost of renewable energy is currently falling and further decreases are expected with the increase in demand and production [1].

Many countries have adopted new energy policies to encourage investment in alternative energy sources such as biomass, solar, wind, and mini-hydro power. Solar energy is one of the most significant sources of renewable energy and promises to grow its share in the near future. An international energy agency study, which examined world energy consumption, estimates that about 30 to 60 Terawatt of solar energy per year will be needed by 2050 [2]. One of the means of harvesting solar energy is photovoltaic cells. The problem with solar energy is that it is not available all the time and that the times when it is most available rarely coincide with the demand for energy. Moreover, photovoltaic plants sometimes experience cloud problems, which negatively affect the efficiency of the photovoltaic (PV) system by lowering its output power. It therefore seems appropriate to store the PV energy accumulated during high irradiance times not only to maintain power supply during low-irradiation times or cloudy periods, but also to provide a continuous electrical output. A battery is the common type of solar energy storage device used for this purpose.

Photovoltaic energy sources can be used as stand-alone systems and grid-connected systems and their applications include water pumping, battery charging, home power supplies, street lighting, refrigeration, swimming-pool heating systems, telecommunications, military space and satellite power systems, and hydrogen production and the layout is shown in figure 1. In the current study, PV system is used as stand-alone system[3].

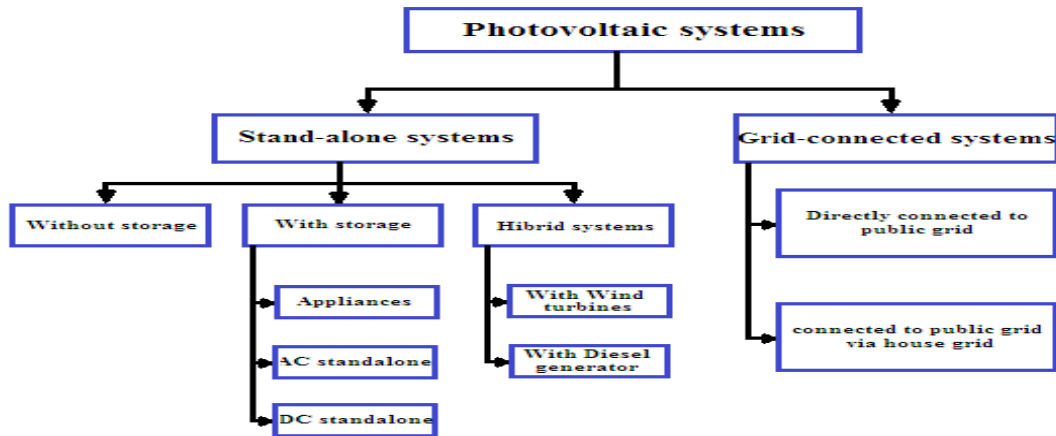

Figure 1. Application of PV systems

.Design Of Photovoltaic cells

An ideal solar cell can be designed with the combination of a current source and a diode where the current produced by the solar cell is proportional to the solar irradiation intensity falling on it. But the practical behavior of a cell is deviated from ideal cell due to the optical and the electrical losses[4,8]. So, in order to develop an electrical equivalent model of a solar cell, appropriate components should be added to the ideal current source. An electrical equivalent circuit of a solar cell is shown in figure 2. [9].

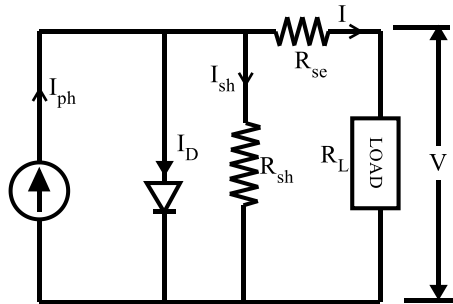

Figure 2.: Equivalent circuit of a solar cell

The optical loss is represented by the current source itself where the generated current I_{ph} is proportional to the light input. Recombination losses are represented by the diode connected in parallel to the current source. But the diode is connected in reverse direction as the recombination current flows in the opposite direction to that of light generated current. The ohmic losses in the cell occur due to the series and shunt resistance denoted by R_{se} and R_{sh} respectively. Series resistance is the resistance offered by the solar cell in the path of current flow and shunt resistance corresponds to the leakage path of the current in a solar cell which is presented in parallel with the current source[10]

$$I = I_{ph} - I_s \exp\left(\frac{q(V + IR_{se})}{kT} - 1\right) - \frac{V + IR_{se}}{R_{sh}} \dots\dots\dots(1)$$

Mathematical Modelling Of PV Module and Array

In order to develop the model of a 40W solar photovoltaic module, a real PV module WS - 40 manufactured by WAAREE SOLAR has been considered as a standard module. For higher requirement of voltage and current, more 40 watt panels can be connected either in series or in parallel. Following table shows the key specification of the PV module under Standard Test Conditions (STC) [11-15].

Table-1: Specification of PV module

Electrical Characteristics	WS-40
Nominal Maximum Power	40W
Optimum Operating Voltage	17V



Optimum Operating Current	2A
Open Circuit Voltage, V_{OC}	21V
Short Circuit Current, I_{SC}	2.54A
Temperature Coefficient of I_{SC} (K_i)	0.005A/°C

The original PV module contains total 36 cells. The series connection is chosen in order to generate the specified voltage from the simulated model with 36 cells. In this system, desired voltage level is achieved by applying a gain on the cell voltage equals to the number of total cells, to develop the model of a 40W PV module. Following equations are required to design a close loop PV module which has the advantage that, PV array can also be designed using that particular model [16-21].

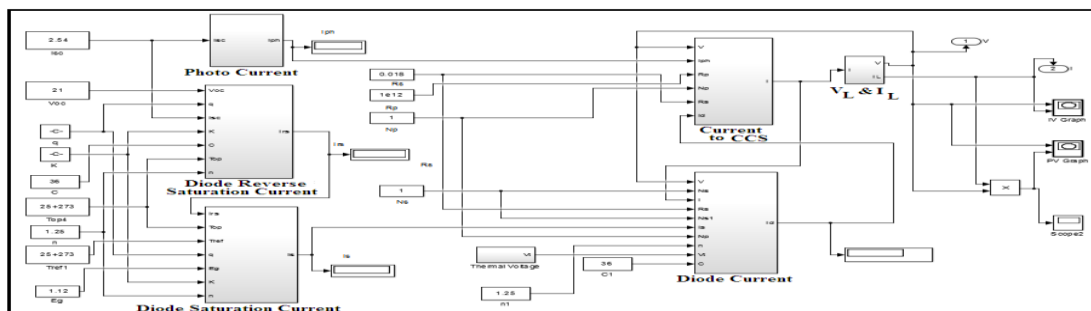

Figure 3: Simulink model of a PV module

The simulation model of the PV module based on the above equations is shown in figure 3 and the I-V and P-V curve for 40 watt PV module is shown in figure 4 and 5 respectively. Those simulated waveforms are traced for Standard Test Condition (STC). But there occurs some variation in the field conditions such as variation in the irradiance and temperature. So that the I-V and P-V curves are varied corresponding to particular variation.

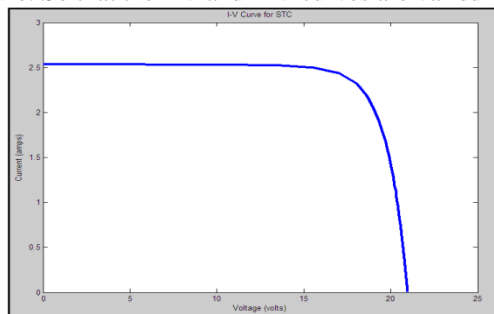

Figure 4 : I-V curve for STC

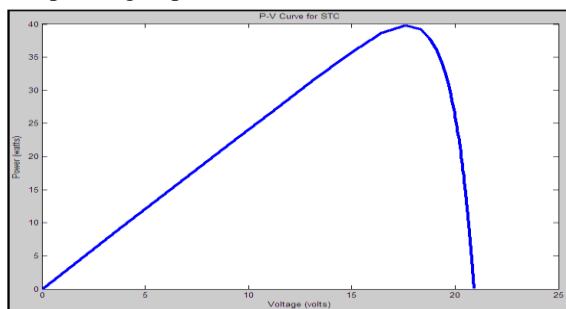

Figure 5 : P-V curve for STC

2 .SIMULATION RESULT AND DISCUSSION

2.1.Effect of Irradiance

The photo current (I_{ph}) which depends upon two measure parameters, irradiance and temperature which affects the efficiency of the solar cell. When irradiance falls, the solar cell current decreases which results in decrease in the cell voltage. Figure 6 and 7 shows the I-V and P-V curve respectively for the variation in irradiance level. Here, the simulation is done for 1000 W/m², 800 W/m², 600 W/m², 400 W/m² and the cell temperature is kept constant at 25°C.[22-26]

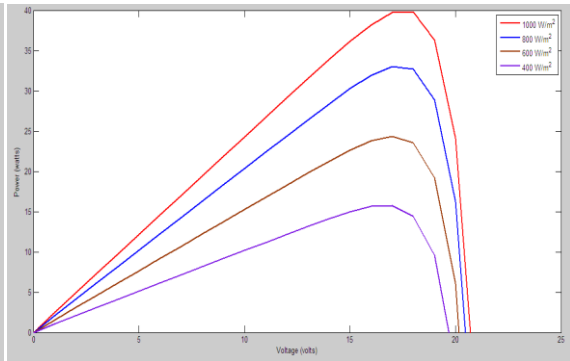
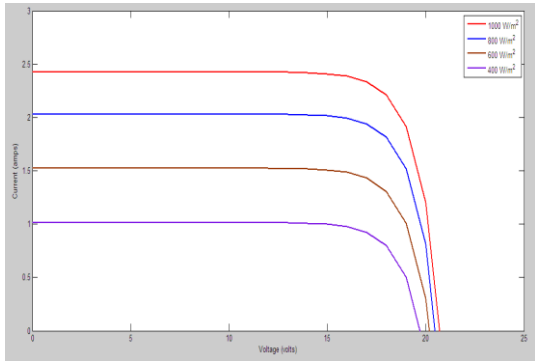

Figure 6 : I-V curves for different irradiance level Figure 7 : P-V curves for different irradiance level

2.2.Effect of Temperature

Generally the photo current is also a function of temperature and both are proportional to each other but energy production dropped off steadily, once the panel temperature reaches 45 degree Celsius. That means, if the temperature exceeds this permissible value, then the current value may increase but the voltage decreases. The effect of temperature on the PV power production varies depending on the solar panel units employed. Higher number of photovoltaic units are less negatively affected by high temperatures than the lower units. The effect of temperature on the I-V and P-V curve is shown in figure 8 and 9 respectively.

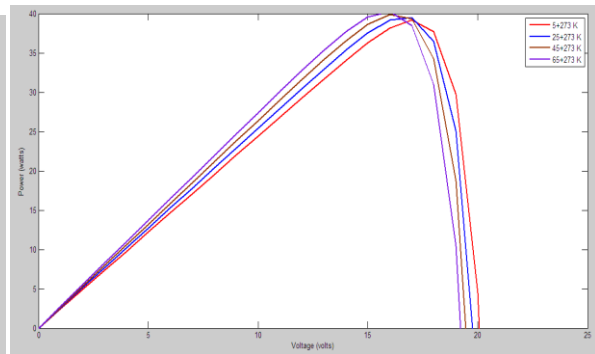
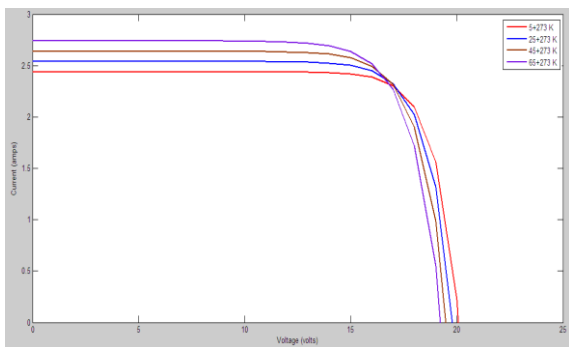

Figure 8 : I-V curves for different temperature level Figure 9: P-V curves for different temperature level

2.3 .Effect of Partial Shading

As described in chapter 2, nine PV modules are connected in series-parallel combination to create an array. Figure 10 and 11 shows the I-V and P-V curves for unshaded and partially shaded modules. Here the unshaded curves (marked as red) represents that irradiance is uniformly distributed on all modules. But the rest curves shows that the irradiance is different. Middle I-V and P-V curves (marked as blue) shows that the array is absorbing two different levels of irradiance. Therefore, the P-V curve is having two peaks where the higher one is known as global maximum point and the lower one is known as local maximum point. Similarly the lower curves (marked as brown) shows the results for three different levels

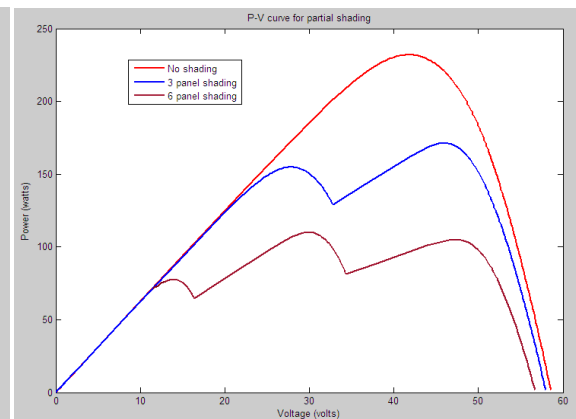
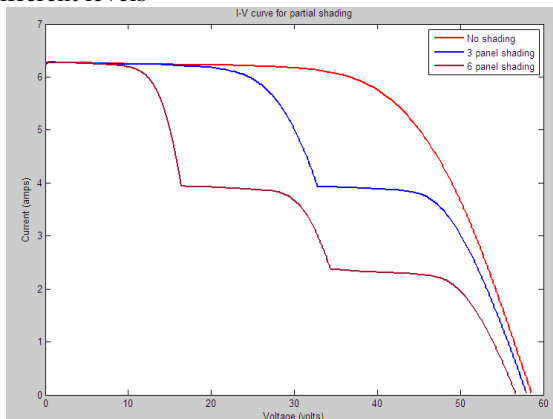

Figure 10 : I-V curves for partial shading Figure 11 : P-V curves for partial shading



2.4 .MLI with and without DC-DC Converter

As asymmetric multi level inverter is used for the ac loads, some of the dc inputs require higher value of voltage and it can be boosted by dc-dc converter from a single module but nonlinearity increases due to the presence of inductors and capacitors in the dc-dc converter and also due to the dc to dc conversion (either buck or boost). This results to higher THD. It can be noted that, high efficient MPPT technology can be used for single input inverters for further use of ac loads. But in this MLI technology, more number of modules are required to provide the higher value of voltage.

According to the model and formulae of twenty five level inverter, if the values of dc sources of first sub-multilevel cell is V_{dc} then the values of dc sources of second sub-multilevel cell is $5V_{dc}$. Here, in the first sub-multi level cell, single 40W modules are fed whose V_{oc} is 21 volts and the second sub-multi level cell requires 105 volts. So, the second sub-multi level cell can be fed by either boosting the 21volts to 105 volts or by connecting five 40 W panels in series. An analysis can be done by comparing the output voltage waveforms and THD for both the case. Figure 12 and 13 shows the output waveforms of 25 level MLI with and without buck-boost converter respectively. Harmonic content of the MLI output is found through FFT analysis. It is measured by THD and found to be 25.66 % with buck-boost converter and 3.59 % without buck-boost converter which are shown in figure 14 and 15 respectively.

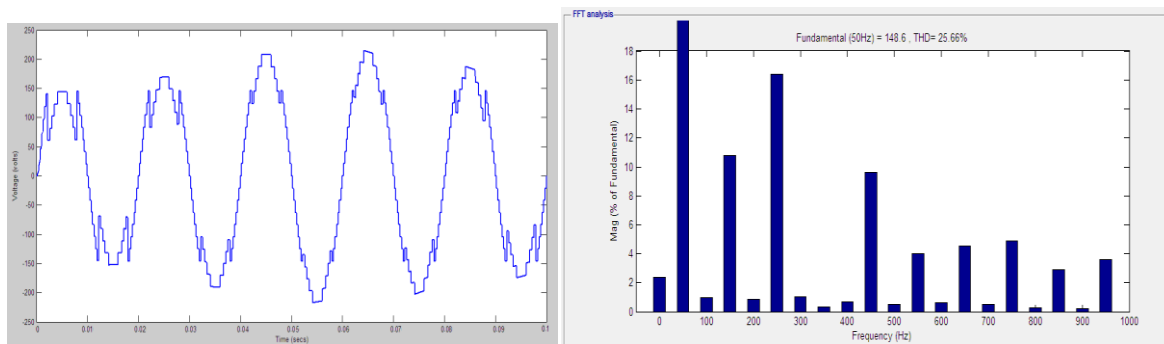

Figure 12: Output voltage waveform of Twenty five level MLI with buck-boost converter

Figure 13 : THD of Twenty five level MLI with buck-boost converter

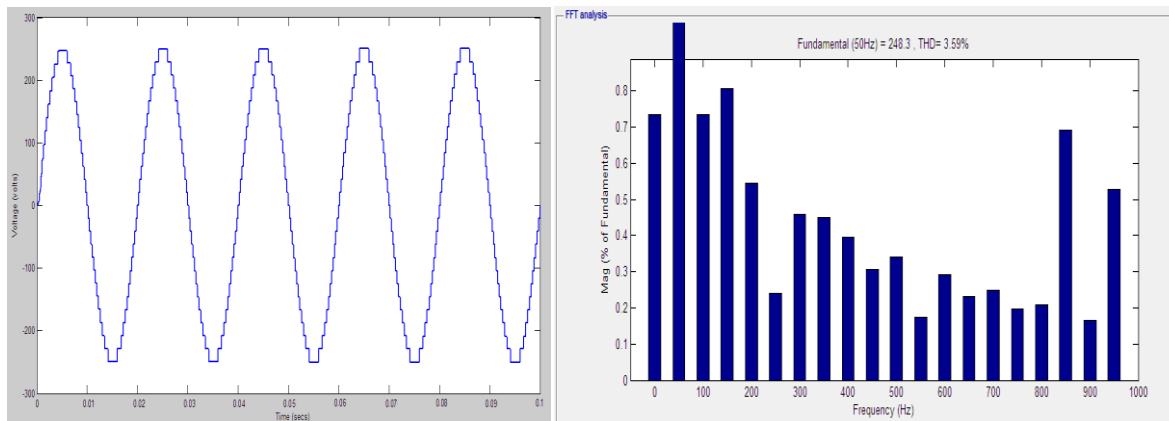

Figure 14: Output voltage waveform of Twenty five level MLI without buck-boost converter

Figure 15 : THD of Twenty five level MLI without buck-boost converter

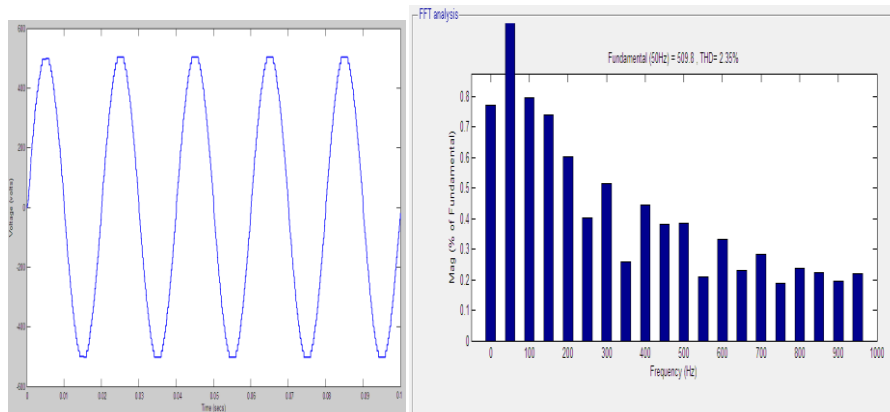

Figure 16: Output voltage waveform of Forty ninelevel MLI without buck-boost converter

Figure 17: THD of Forty ninelevel MLI without buck-boost converter

Figure 16 shows the output voltage waveform of a proposed forty nine level inverter which is approximately sinusoidal and requires less filter circuits. THD analysis is shown in figure 17. Total harmonic distortion profile of a forty nine level MLI is less nearly about 2.35 % which is less than the IEEE standard 519

CONCLUSION

This paper provides an efficient multi level inverter topology for standalone PV system with and without buck-boost converter. It has been explained that when the solar PV panel is directly connected to the load, the power delivered is not optimal. Moreover, solar PV power fluctuates due to variations in irradiance and temperature levels. Thus, an MPPT system is needed to achieve the optimum or peak power under changing environmental operating conditions. When a PV panel is equipped with an MPPT system, it includes a solar panel, an MPPT algorithm, and a DC-DC converter. Each component was modelled and simulated in a Matlab/Simulink environment.

REFERENCES

- [1] G.Boyle, "Renewable Energy, Power for a sustainable future", Oxford University Press in association with the Open University, second edition, 2004.
- [2] H. J. Moller, "Semiconductors for Solar Cells, Artech House", Inc, Norwood, MA, 1993.
- [3] R.Faranda, S. Leva, "Energy comparison of MPPT techniques for PV Systems", wseas transactions on power systems. Issue 6, Volume 3, June 2008.
- [4] J.M. Enrique, J.M. Andujar, M.A. Bohorquez, "A reliable, fast and low cost maximum power point tracker for photovoltaic applications", Science Direct, Solar Energy 84 (2010)79-89, 14 November 2009.
- [5] D.P Hohm& M.E Ropp "Comparative Study of Maximum Power Point Tracking Algorithms", Progress in Photovoltaic: Research and Applications page 47-62, November 2002.
- [6] J. Rodriguez, J.S. Lai, F.Z. Peng, Multilevel inverters: a survey of topologies, controls, and applications, IEEE Transactions on Industrial Electronics 49 (4) (2002) 724–738.
- [7] T. J. Liang, Y. C. Kuo and J. F. Chen. "Single-stage photovoltaic energy conversion system," IEEE Proceedings Electric Power Applications.
- [8] Y. Jiang, J. A. A. Qahouq and I. Batarseh, "Improved solar PV cell Matlab simulation model and comparison," Proc. of 2010 IEEE International Symposium on Circuits and Systems, pp 2770-2773
- [9] W. Xiao; F. F. Edwin, G. Spagnuolo and J. Jatskevich, "Efficient Approaches for Modeling and Simulating photovoltaic systems," IEEE Journal of Photovoltaics, vol.3, no.1, pp. 500-508, Jan. 2013
- [10] W. Chen, H. Shen, B. Shu, H. Qin and T. Deng, "Evaluation of performance of MPPT devices in PV systems with storage batteries," Renewable Energy, vol.32, no.9, pp. 1611-1622, July 2007.
- [11] J. C. H. Phang, D. S. H. Chan, and J. R. Phillips, "Accurate analytical method for the extraction of solar cell model parameters," Electron. Lett., vol. 20, no. 10, pp. 406-408, 1984.
- [12] M. Wolf, G. J. Noel, and R. J. Steern, "Investigation of the double exponential in the current-voltage characteristics of silicon solar cells," IEEE Trans. Electron Devices, vol. ED-24, pp. 419-428, 1917.
- [13] D. S. H. Chan, J. C. H. Phang, J. R. Phillips, and M. S. Loong, "A comparison of extracted solar cell parameters from single and double lumped circuit models," in Tech. Dig. 1st Int. Photovoltaic Science and Engineering Conf (Kobe, Japan), pp. 151-153, Nov. 13-16, 1984
- [14] Savita Nema, R.K. Nema, Gayatri Agnihotri, "MATLAB/Simulink based study of photovoltaic cells / modules / array and their experimental verification", International journal of Energy and Environment, vol.1, No.3, pp.487-500, 2010.
- [15] Kinal Kachhiya, Makarand Lokhande, Mukesh Patel, "MATLAB/Simulink Model of Solar PV Module and MPPT Algorithm", Proceedings of the National Conference on Recent Trends in Engineering and Technology, 2011.
- [16] HHuan-Liang Tsai, Ci-Siang Tu, Yi-Jie Su, "Development of Generalized Photovoltaic Model Using MATLAB/SIMULINK", Proceedings of the World Congress on Engineering and Computer Science WCECS, San Francisco, USA, 2008.



- [17] N. D. Kaushika and A. K. Rai, "An investigation of mismatch losses in solar photovoltaic cell networks," *Energy*, vol. 32, no. 5, pp. 755–759, May 2007.
- [18] T.P.Nguyen, "Solar Panel Maximum Power Point Tracker", Undergraduate Thesis, University of Queensland, 19 October 2001.
- [19] Mohan, Underland, Robbins. *Power Electronics, Converters, Applications and Design*, Media Enhanced Third edition, John Wiley & Sons, 2003.
- [20] R.W. Erickson, "DC-DC Power Converters", Article in *Wiley Encyclopedia of Electrical and Electronics Engineering*, University of Colorado, 2000.
- [21] R.W.Erickson, D.Maksimovic, "Introduction to Power Electronics, Fundamentals of Power Electronics" 2nd edition, Springer 2000, ECEN 2060, spring 2008.
- [22] W.Xiao, "Improved Control of Photovoltaic Interfaces", Doctoral Thesis, British Columbia University, April 2007.
- [23] W.Xiao, N.Ozog, and W.G.Dunford, "Topology Study of Photovoltaic Maximum Power Point Tracking", *IEEE transactions on Industrial electronics*, Vol. 54, No 3, June 2007.
- [24] B.Subudhi, and R. Pradhan, "A comparative study on maximum power point tracking techniques for photovoltaic power systems", *IEEE Transactions on Sustainable Energy*, vol. 4, no. 1, January 2013, pp. 89-98.
- [25] Oscar L., Maria Teresa Penella, "A New MPPT Method for Low-Power Solar Energy Harvesting", *IEEE Transactions on Industrial Electronics*, vol. 57, no. 9, September 2010, pp. 3129-3138.
- [26] C. Carrero, J. Amador, and S. Arnaltes, "A single procedure for helping PV designers to select silicon PV module and evaluate the loss resistances", *Renewable Energy*, 2007.