



Performance Analysis of Digital Video Broadcasting – Cable (DVB-C) System with 64-QAM Modulation and Interleaving Schemes

Sajjad Iqbal¹, Pallvi Gupta², Satish Kumar³

¹M.Tech. Student, ECE Department, GRIMT, Radaur, Haryana, India

²Assistant Professor, ECE Department, GRIMT, Radaur, Haryana, India

³Chairperson, ECE Department, GRIMT, Radaur, Haryana, India

Abstract: DVB-C is the most widely used standard for interactive television. DVB-C uses the MPEG-2 standard for coding the data, as well as Forward Error Coding, Reed Solomon Coding and Convolutional coding to make the signal robust against the high amount of error that comes with transmission. It also uses QPSK to modulate the signal, which makes the information be encoded in the phase instead of the amplitude, which also helps with making the signal robust enough for the channel. But due to increase in number of users and changing needs of users in the field of communications and entertainment, there are new challenges that the current standards are not able to satisfy. So as the number of users increases the system complexity and interference also increases. The communication channel is not free from the effects of channel impairments such as noise, interference and fading. These channel impairments caused signal distortion and signal to ratio (SNR) degradation. This problem can be overcome by implementing the system with different modulation and error detection and correction schemes. So first design a DVB-C system with Rectangular 64-QAM Modulator and Reed-Solomon Encoder. Then analyze this system with different interleaving schemes such as convolutional, helical, matrix, block and random interleaving and find the best suited interleaving scheme with lowest bit error rate.

Keywords- DVB-C, QAM, RS, Interleaving, BER.

I. INTRODUCTION OF DVB-C

Digital Video Broadcasting - Cable is the DVB European consortium standard for the broadcast transmission of digital television over cable. This system transmits an MPEG-2 or MPEG-4 family digital audio/digital video stream, using a QAM modulation with channel coding. The standard was first published by the ETSI in 1994, and subsequently became the most widely used transmission system for digital cable television in Europe, Asia and South America. It is deployed worldwide in systems ranging from the larger cable television networks (CATV) down to smaller satellite master antenna TV (SMATV) systems.

Digital video broadcasting cable (DVB-C) refers a digital broadcast standard that cable as the transmission medium. DVB-C is one of the digital video broadcasting standards used in different scenarios of television and video transmission. The DVB standards vary in regards to requirements, performance and accessibility.

Cable media is very successful at delivering high-quality video and the latest multimedia features. Fiber optics is a type of high-speed cable medium with more bandwidth and higher quality digital video. Fiber optics also has fewer issues with packet loss, which allows the best quality possible. Coaxial is the alternate cable medium; it is cost effective for service providers compared to fiber optics and is still a good choice if the service provider is only looking to provide an mpeg-2 quality digital video. However, fiber optics is a better choice when providing Internet, TV and telephone services through a single medium.

Development in digital video has brought new features like digital video recording, video on demand and 3D video. These features require more bandwidth to provide the required performance and experience to the user. DVB-C transmission systems consider all the analog and digital requirements and is designed to provide the best services in this regard. DVB-C2 is the upgraded version of DVB-C.

II. SYSTEM MODEL OF DVB

Technical Description of DVB-C Transmitter

(a). Source coding and MPEG-2 multiplexing (MUX): video, audio, and data streams are multiplexed into an MPEG program stream (MPEG-PS). One or more MPEG-PSs are joined together into an MPEG transport stream



(MPEG-TS). This is the basic digital stream which is being transmitted and received by home set top boxes (STB) or relevant integrable decoder module. Allowed bitrates for the transported MPEG-2 depend on a number of modulation parameters: it can range from about 6 to about 64 Mbit/s.

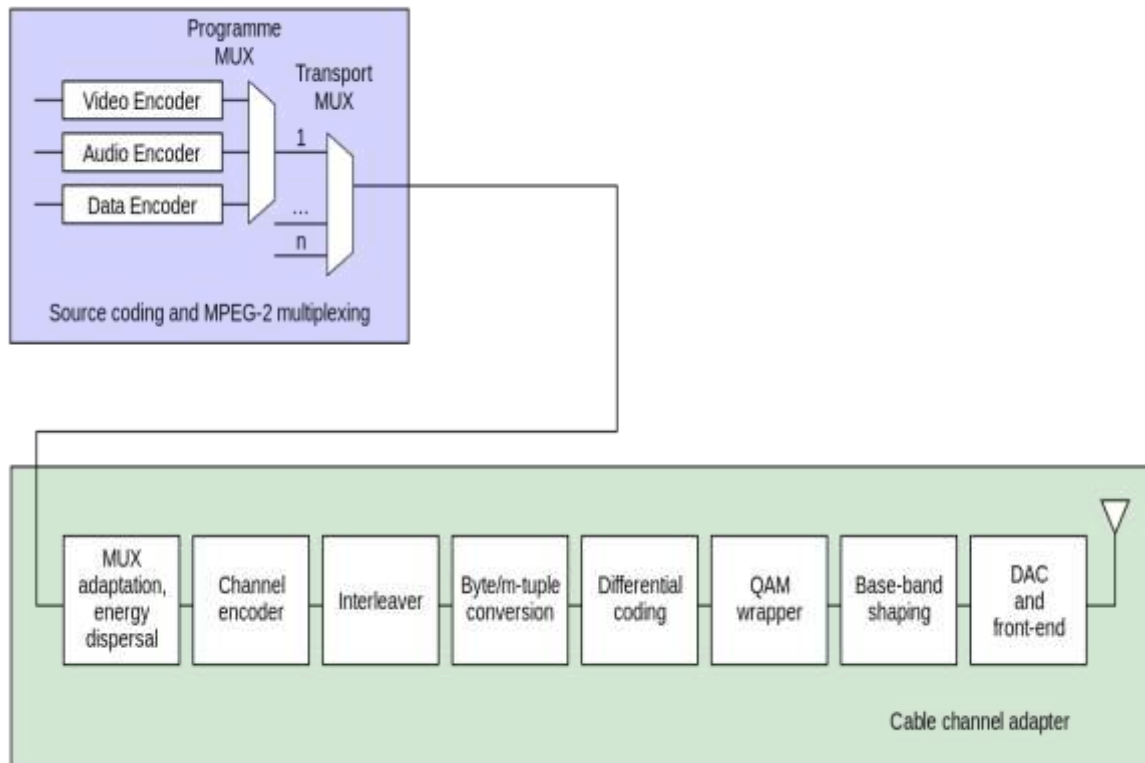

Figure 1. DVB-C Transmission System

- (b). MUX adaptation and energy dispersal: the MPEG-TS is identified as a sequence of data packets, of fixed length (188 bytes). With a technique called energy dispersal, the byte sequence is decorrelated.
- (c). External encoder: a first level of protection is applied to the transmitted data, using a nonbinary block code, a Reed-Solomon RS (204, 188) code, allowing the correction of up to a maximum of 8 wrong bytes for each 188-byte packet.
- (d). External interleaver: convolutional interleaving is used to rearrange the transmitted data sequence, such way it becomes more rugged to long sequences of errors.
- (e). Byte/m-tuple conversion: data bytes are encoded into bit m-tuples ($m = 4, 5, 6, 7, \text{ or } 8$).
- (f). Differential coding: In order to get a rotation-invariant constellation, this unit shall apply a differential encoding of the two Most Significant Bits (MSBs) of each symbol.
- (g). QAM Mapper: the bit sequence is mapped into a base-band digital sequence of complex symbols. There are 5 allowed modulation modes: 16-QAM, 32-QAM, 64-QAM, 128-QAM, 256-QAM.
- (h). Base-band shaping: the QAM signal is filtered with a raised-cosine shaped filter, in order to remove mutual signal interference at the receiving side.
- (i). DAC and front-end: the digital signal is transformed into an analog signal, with a digital-to-analog converter (DAC), and then modulated to radio frequency by the RF front-end.

III. INTERLEAVING TECHNIQUES

Interleaving is a simple yet powerful technique that can be used to enable a random error correcting code (such as the Reed-Solomon code) to perform burst error correction. Interleaving is a way to arrange data in a non-contiguous way to increase performance. It is typically used in error-correction coding, particularly within data transmission, for multiplexing of several input data over shared media[5]. In telecommunication, it is implemented through dynamic bandwidth allocation mechanisms, where it may particularly be used to resolve quality of service and latency issues. In streaming media applications, it enables quasi-simultaneous reception of input streams, such as video and audio.



Signals traveling through a mobile communication channel are susceptible to fading. The error-correcting codes are designed to combat errors resulting from fades and, at the same time, keep the signal power at a reasonable level. Most error-correcting codes perform well in correcting random errors[6].

However, during periods of deep fades, long streams of successive or burst errors may render the error-correcting function useless. Interleaving is a technique for randomizing the bits in a message stream so that burst errors introduced by the channel can be converted to random errors. We want to send the message "ARE YOU SURE THAT THEY ARE COMING TO LUNCH WITH US" over a fading channel. One way to interleave the message is to load it into a matrix of four rows and ten columns. We truncate the message into four parts and load them into the four rows. Then we read the message out from the top, column by column. The resulting randomized message is sent through the channel. The channel introduces several burst errors into the message. As a result, the underlined alphabets are received in error. At the receiving end, a deinterleaver reconstructs the message using the same matrix, except in this case the deinterleaver loads the received message into columns first, and then reads the message out from the rows. As we can see, the burst errors are indeed converted to scattered random errors.

Original message:

ARE YOU SURE THAT THEY ARE COMING TO LUNCH WITH US

Interleave matrix:

A	R	E	Y	O	U	S	U	R	E
T	H	A	T	T	H	E	Y	A	R
E	C	O	M	I	N	G	T	O	L
U	N	C	H	W	I	T	H	U	S

Interleaved message:

ATEU RHCN EAOC YTMH OTIW UHNI SEGT UYTH RAOU ERLS

Then interleaving techniques are used for randomizing the bits in a message stream so that burst errors introduced by the channel can be converted into random errors. Different types of interleavers are used in CDMA namely Convolutional, Matrix, Helical, Random etc.

1. Block Interleaver

The Block Interleaver rearranges the elements of its input without repeating or omitting any elements. The input can be real or complex. If the input contains N elements, then the Elements parameter is a vector of length N that indicates the indices, in order, of the input elements that form the length- N output vector. For example, if Elements is [4,1,3,2] and the input is [40;32;59;1], then the output vector is [1;40;59;32].

2. Convolutional Interleaver

A convolutional interleaver consists of a set of shift registers, each with a fixed delay. In a typical convolutional interleaver, the delays are nonnegative integer multiples of a fixed integer[5]. Each new symbol from an input vector feeds into the next shift register and the oldest symbol in that register becomes part of the output vector. A convolutional interleaver has memory; that is, its operation depends not only on current symbols but also on previous symbols[2].

3. Matrix Interleaver

The Matrix Interleaver block performs block interleaving by filling a matrix with the input symbols row by row and then sending the matrix contents to the output port column by column[7]. The Number of rows and Number of columns parameters are the dimensions of the matrix that the block uses internally for its computations. For example, if the Number of rows and Number of columns parameters are 2 and 3, respectively, then the interleaver uses a 2-by-3 matrix for its internal computations. Given an input signal of [1; 2; 3; 4; 5;6], the block produces an output of [1; 4; 2; 5; 3;6].

4. Helical Interleaver

The Helical Interleaver block permutes the symbols in the input signal by placing them in an array in a helical fashion and then sending rows of the array to the output port. The block uses the array internally for its computations[7]. If C is the Number of columns in helical array parameter, and N is the Group size parameter, then the block accepts an input of length $C*N$ at each time step. For example, Suppose that $C = 3$, $N = 2$. After receiving inputs of [1:6]', [7:12]', and [13:18]', the block's internal array looks like the schematic below. The coloring of the inputs and the array indicate how the input symbols are placed within the array. The outputs at the first three time steps are [1; -1; -1; 2; 3; -1], [7; 4; 5; 8; 9; 6], and [13; 10; 11; 14; 15; 12].



5. Random Interleaver

The Random Interleaver block rearranges the elements of its input vector using a random permutation. The Number of elements parameter indicates how many numbers are in the input vector. If the input is frame-based, then it must be a column vector.

IV. DVB-C PERFORMANCE ANALYSIS

Simulation of Digital Video Broadcasting-Cable (DVB-C) system is done in Simulink tool of MATLAB. The simulation results are plotted in term of the performance of DVB-C system that is Bit Error Rate (BER). First the DVB-C system is analyzed with 64-QAM Modulation and Reed-Solomon Encoding and the Bit Error Rate (BER) of DVB-C system with these modulation schemes is calculated to check the system performance. Analysis was done by observing the simulation result and tabulating the analysis results to make it more convenient to be read. In the performance analysis of DVB-C system the transmitted signal, received signal, scattered plot and bit error rate of the systems are analyzed.

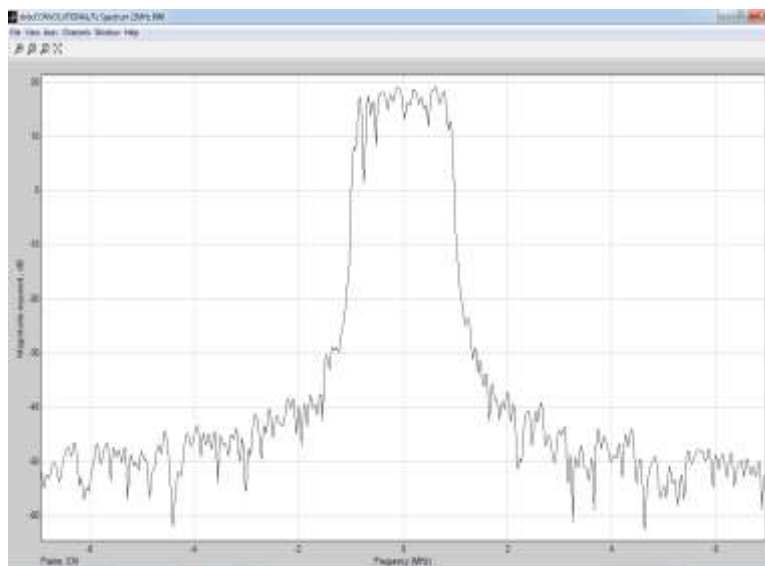

Figure 2. Transmitted Signal of DVB-C.

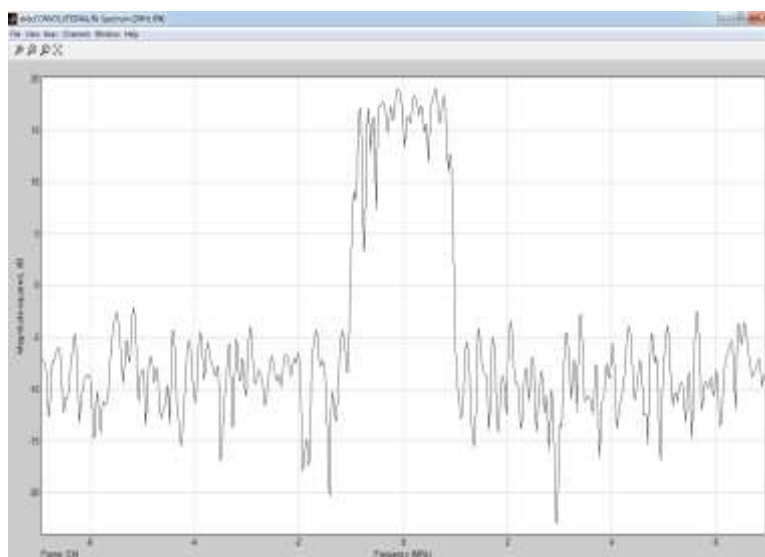

Figure 3. Received Signal of DVB-C.

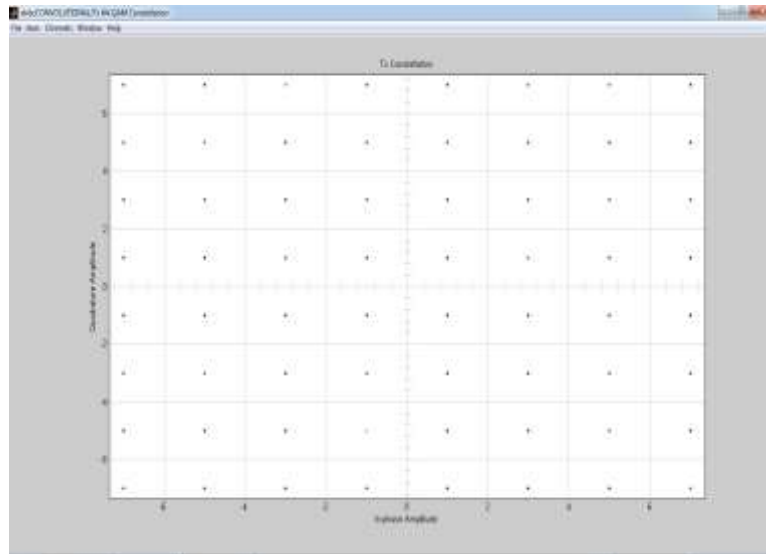

Figure 4. Scatter Plot of DVB-C Transmitted Signal.

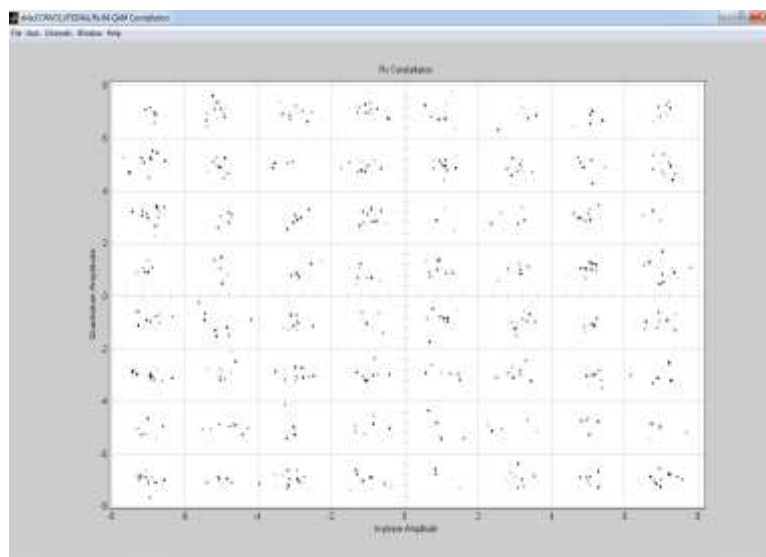

Figure 5. Scatter Plot of DVB-C Received Signal.

The Figure shows the transmitted and received signal of DVB-C system. To plot these signals spectrum scope is used. The Spectrum Scope block computes and displays the periodogram of the input. From the plot of transmitted and received signal it is clear that the received signal is so much distorted as comparison to transmitted signal due to channel. The simulation results are plotted in term of the performance of DVB-C system that is transmitted, received signal.

Now the Bit Error Rate (BER) of DVB-C system is analyzed. First calculate the BER for the DVB-C system with modulation scheme Rectangular 64-QAM and Reed-Solomon Encoding technique. The BER is calculated with error rate calculation block. In this block the transmitted and received signals are compared to calculate the BER.

After this DVB-C system is analyzed with different interleaving schemes to improve the BER. Interleaving is a simple yet powerful technique that can be used to enable a random error correcting code (such as the Reed-Solomon code) to perform burst error correction. Interleaving is a way to arrange data in a non-contiguous way to increase performance. It is typically used in error-correction coding, particularly within data transmission, for multiplexing of several input data over shared media.



Table 1. BER of DVB-C with Block Interleaver.

Interleavers	Block Interleaver	Convolutional Interleaver	Matrix Interleaver	Random Interleaver	Helical Interleaver
Bit Error Rate	0.0001416	0.0001383	0.0001430	0.0001456	0.0001507
Total Error Bits	1475	1440	1489	1516	1570
Total Bits	10420000	10420000	10420000	10420000	10420000

From these tables it is clear that while analyzing the different interleaving schemes of DVB-C system with Reed-Solomon encoding and Rectangular 64-QAM modulation, the convolutional interleaver gives better bit error rate i.e. 0.0001383 as compare to other interleaving schemes.

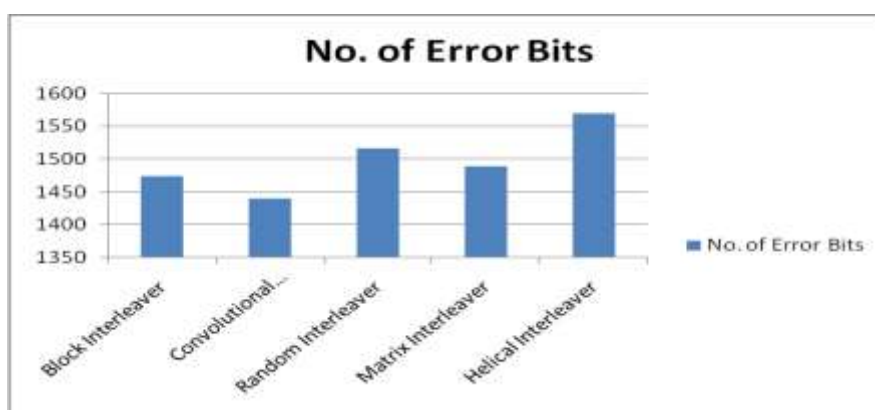

Figure 6. No. of Error Bits in Different Interleavers.

V. CONCLUSION

The digitalisation of television signals today is a well-known and widely implemented process. It consists basically of the representation of a picture - and the accompanying sound - by a binary bit-stream, a series of '0's and '1's. However, compression and transmission of these signals through a communications channel- satellite, terrestrial or cable- becomes practical only after the raw digital data has been subject to a series of processes. And therefore, if it is wished to be able to interconnect digital TV equipment from different suppliers, or to receive such transmissions satisfactorily, different modulation and error detection schemes are used.

So DVB-C system is designed to withstand with interference and fading in communication channel. Channel coding and modulation is needed for a system in order to sustain in any type of environment especially in multipath fading channel. Here DVB-C system is first analyzed with RS encoding and different interleaving schemes i.e. convolutional, helical, random, block and matrix interleaving. It is concluded that DVB-C system with rectangular 64-QAM modulation with Convolutional Interleaving is best suited scheme for proposed system with 0.0001383 BER.

REFERENCES

- [1]. Drakshayini and Arun Vikas Singh, "Integrated Antenna for the Digital Audio Broadcasting and Digital Video Broadcasting by Orthogonal Frequency Division Multiplexing", International Journal of Innovative Technology and Exploring Engineering, Vol. 8, Issue 11, pp. 3320-3328, 2019.
- [2]. Loreta Andoni and Aleksander Biberaj, "Multi-Antenna Systems in DVB-C2/SFN Networks", International Refereed Journal of Engineering and Science, Vol. 8, Issue 1, pp. 66-70, 2019.
- [3]. Bundit Ruckveratham and Sathaporn Promwong, "Empirical single frequency network threshold for DVB-C2 based on laboratory experiments", Turkish Journal of Electrical Engineering & Computer Sciences, pp. 3342-3355, 2019.
- [4]. Sukamto and R. Gaguk Pratama Yudha, "Analysis of Digital Video Broadcasting - Terrestrial Second Generation (DVB-T2) Based on OFDM System on Transmission Aspect," International Research Journal of Advanced Engineering and Science, Vol. 3, Issue 3, pp. 135-139, 2018.
- [5]. Anugrah Nair, Gaurav Gupta and Kartik Srinivas, "Review On Multiple Access Techniques Used In Mobile Telecommunication Generations", International Research Journal of Engineering and Technology, Vol. 5, Issue 10, pp. 350-354, 2018.
- [6]. Syed Gilani Pasha and Vinayadatt V Kohir, "Implementation and Performance Analysis of OFDM Based DVB-C System Using Matlab and HDL Coder", International Journal for Research in Applied Science & Engineering Technology, Vol. 5, Issue 9, pp. 466-477, 2017.
- [7]. K. Sambasivarao, N.V. Ramana and M. Venkata Manikanta, "Effect Of Time Interleaving Parameters in Mobile DVB-T2 Systems", International Journal Of Engineering Sciences & Research Technology, pp. 175-181, 2017.



International Journal of Innovative Research in Electrical, Electronics, Instrumentation and Control Engineering

Vol. 9, Issue 9, September 2021

DOI [10.17148/IJIREEICE.2021.9902](https://doi.org/10.17148/IJIREEICE.2021.9902)

- [8]. Monika Kapoor and Dr. Anubhuti khare, " Performance Analysis of Reed Solomon Code & BCH Code for various Modulation Schemes over AWGN Channel", International Journal of Applied Engineering Research, Vol. 12, No. 24, pp. 15801-15813, 2017.
- [9]. Syed Gilani Pasha and Vinayadatt V Kohir, "Performance Analysis/Study of OFDM Based DVB-T System under AWGN, Rayleigh and Rician Channels", National Conference on Advances in Computing and Communications, pp. 96-102, 2016.
- [10]. Aasheesh Shukla and Vinay Kumar Deolia, "Performance Analysis of Chaos Based Interleaver in IDMA System", International Journal on Communication Technology, vol. 7, issue 4, pp. 1397-1401, December 2016.
- [11]. Prakash Patel, Dr. Snehlata kothari and Dr. Dipesh Kamdar, "Performance of Digital Video Broadcasting (DVB-T) using Filter for 64-QAM", International Journal of Engineering Trends and Technology, Vol. 38, No. 2, pp. 71-74, 2016
- [12]. Sneha Pandya and Charmy Patel, "Comparative Analysis and Simulation of various QAM Techniques as used in DVBT2", Indian Journal of Science and Technology, Vol. 9, pp. 1-9, 2016.
- [13]. Ankita Jhamb, "A Review On Interleave Division Multiple Access In Underwater Communication", International Journal of Engineering Development and Research, Vol. 4, Issue 4, pp. 873-876, 2016.
- [14]. Shweta Bajpai and D. K. Srivastava, "Performance Analysis of IDMA Schemes using different Coding techniques with receiver diversity using Random Interleaver", International Journal of Science Research Engineering & Technology, vol. 3, issue 6, pp. 1008-1012, September 2014.
- [15]. Sweta Singh and Parul Malhan, "A Review Paper on Multiple Access Techniques for Mobile Communication", International Journal For Innovative Research in Technology, Vol. 1, Issue 6, pp. 1244-49, 2014.
- [16]. Pramod Movva and A Krishna Chaitanya, "Analysis of Different Pilot Patterns in Various Channels for DVB-T2", International Journal of Advanced Research in Computer and Communication Engineering, Vol. 3, Issue 9, pp. 7979-7981, 2014.