



"Fingerprint Based Vehicle Ignition System"

Dharmendra R Bisen¹, Sana Shaikh², Umesh Choudhary³, Anushree Nimgade⁴, Neha Harinkhede⁵, Himanshu Wasnik⁶, Prof. Snehal Paliwal⁷

Dept. of Electronics & Communication Engineering, Tulsiramji Gaikwad Patil college of Engineering & Technology, Nagpur, Maharashtra, India¹⁻⁷

Abstract: Biometric systems have overtime served as robust security mechanisms in various domains. Fingerprints are the oldest and most widely used form of biometric identification. A critical step in exploring its advantages is to adopt it for use as a form of security in already existing systems, such as vehicles. This research work focuses on the use of fingerprints for vehicle ignition, as opposed to the conventional method of using keys. The prototype system could be divided into the following modules: fingerprint analysis software module that accepts fingerprints images; hardware interface module and the ignition system module. The fingerprint recognition software enables fingerprints of valid users of the vehicle to be enrolled in a database. Before any user can ignite the vehicle, his/her fingerprint image is matched against the fingerprints in the database while users with no match in the database are prevented from igniting the vehicle. Control for the ignition system of the vehicle is achieved by sending appropriate signals to the parallel port of the computer and subsequently to the interface control circuit. The developed prototype serves as an impetus to drive future research, geared towards developing a more robust and embedded real-time fingerprint based ignition systems in vehicles.

Keywords: Fingerprints, Biometrics, Ignition, Interface, Vehicles etc.

I. INTRODUCTION

In modern day, vehicles anti-theft system is our prime important duty to secure our vehicle by the means of fingerprinting. [1] The main focus while developing the vehicle anti-theft system is to protect our system from theft by providing the anti-theft protection. For the protection, first we should restrict the starting of vehicle, only to the authorized persons have this ability to start the car without the use of keys, once it has identified by the Fingerprint sensor. [2] The Fingerprint of the owner and other authorized persons are stored into the database beforehand and at the time of starting engine of the vehicle, scanned fingerprints are being crosschecked with the database. The biometric scheme is used as the primary layer of protection since the chances of it being duplicated is very less. [2] Fingerprint images are considered as the most perfect quality pattern for recognition because this image cannot be manipulated by the different variations in skin or by the different expressions. So it is necessary to measure all the locations very carefully which lead to a result of a more reliable data comparison by extracting all the features and the probability of being forgery and duplication is been reduced. The main advantage of using a fingerprint pattern is that it is very low in cost as compared to other biometric system and the acceptance of using this system by the user is very high. [3] It can be easily adaptable in the environment which can enhance the security and robustness of the vehicles. Therefore, the usefulness of designing and implementing a biometric security system using fingerprint technology, to prevent unauthorized vehicle starting the engine cannot be overemphasized.

II. LITERATURE REVIEW

According to the recent Research paper in 2013 titled "Fingerprint based locking system", the author specially developed this project to improve the Security of the bike. The objective of this project is to study and understand the concept of Fingerprint Module. The project uses Fingerprint Module, Relay, Buzzer, Arduino module. The project also uses buzzer for indication purpose. The bike owner has the permission to add or delete fingerprints thus allowing & disallowing people to ride the bike.. [2] The major disadvantage of this project is they are If battery low then system will not work. Also the cost of ignition system is still low since ignition system is designed for only multi purpose.

According to the Research paper in 2011 titled "A Prototype of a Fingerprint Based Ignition Systems in Vehicles, in this paper author has discussed on the Prototype of a fingerprint based ignition system of the vehicle. In this application the project will be authorized person drive bike, car, School bus etc. the theft of the vehicle will be controlled to a predefined limit. LCD is used for showing the various types of messages after start the ignition bike. The author has worked only on The fingerprint recognition software enables fingerprints of valid users of the vehicle to be enrolled in a database.



According to the Research paper in 2010 titled “A Survey of Emerging Biometric Technologies”, in this paper author has discussed on the Fingerprint processing includes two parts: fingerprint enrollment and fingerprint matching (the matching can be 1:1 or 1:N).

When enrolling, user needs to enter the finger two times. The system will process the two time finger images, generate a template of the finger based on processing results and store the template. System will search the whole finger library for the matching finger. In both circumstances, system will return the matching result, success or failure.

2. CIRCUIT DIAGRAM OF IGNITION SYSTEM

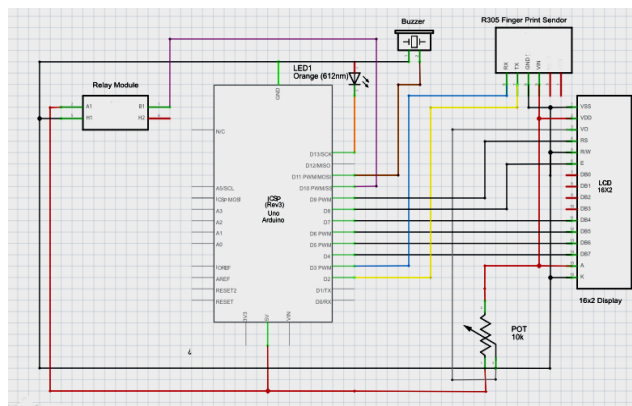

Fig -1: Circuit Diagram

2.1 WORKING /DISCRIPTION

The finger is placed on the fingerprint scanner mounted on the bike's dash board to start the bike engine. The fingerprint scanner compares the finger impression with the ones that were stored in its memory when the system was first installed on the bike. The bike owner has the permission to add or delete fingerprints thus allowing & disallowing people to ride the bike.

If the finger impression matches with those stored in "R305" finger print scanner memory then access or permission is granted and you can start the bike.

If the fingerprint does not match, the bike does not start and play buzzer for attention ie no unauthorized person can ride the bike.

3. RESULT

In this projects we have studies all the aspects that makes vehicle ignition system a compulsory as well as convenient accessory.

4. CONCLUSIONS

Fingerprint Recognition was the first biometric approach to verify the person by downloading the images of sample in the database. The image is first analyzed and then identified, extracted and stored the images in the file of database. For the identification process, first it compare the query image against with the image stored in the database and then it verified.

From the above result, it has been cleared that the use of the biometric system offers the better and more reliable resultant. Moreover, it is restricting the starting of the vehicles by unauthorized user. Only the fingerprint image

REFERENCES

- [1] Omidiora E. O. “A Prototype of a Fingerprint Based Ignition Systems in Vehicles” European Journal of Scientific Research ISSN 1450-216X Vol.62 No.2 (2011), pp. 164-171.
- [2] Karthikeyan.a “FINGERPRINT BASED IGNITION SYSTEM” International Journal Of Computational Engineering Research / ISSN: 2250–3005
- [3] Olufemi Sunday Adeoye “A Survey of Emerging Biometric Technologies” International Journal of Computer Applications (0975 – 8887)Volume 9– No.10, November 2010.