

# Smart LIFI based Parking System

**Samuvel Jakab R<sup>1</sup>, Sridhar V<sup>2</sup>, Yuwan Varshith A<sup>3</sup>, Sathis Kumar N.R<sup>4</sup>**

Student, Electronics and Communication Engineering, Agni College of Technology, Chennai, India<sup>1,2,3</sup>

Assistant Professor, Electronics and Communication Engineering, Agni College of Technology, Chennai, India<sup>4</sup>

**Abstract:** A major issue in public places like shopping malls, museums and hospitals is parking. Parking is the main service used by the people in these private units. The management of these public units invests more time and money in designing parking systems. Existing parking systems are equipped with appropriate sensors and controllers to count the parked cars automatically, but it does not indicate empty parking slots. These systems consume more power and tend to wireless interference. The proposed system, namely, Visible Light Communication based Smart Parking System introduces Visible Light Communication, a data communication technology using a low power Arduino Uno – Atmega328 microcontroller to help drivers to get real-time parking information. Real-time information on free parking slots helps drivers to save time and reduce fuel consumption. Visible Light Communication (VLC) or Li Fi or Optical Wireless technology means the wireless data transfer using LED. Wireless interference is greatly reduced by using VLC. The proposed system is suitable for multiple floor buildings, which involves data gathering from parking side modules integrated in multiple floors of the building. Parking side modules continuously collect the data and intimate the module integrated in the vehicle section. The module in the vehicle section interfaces a GSM modem to send the detected information to the user mobile. The result of the proposed system is validated in an indoor environment.

**Keywords:** LED, LI-FI, WI-FI

## I. INTRODUCTION

In today's fast-growing environment, Visible Light Technology has taken its own place in the data communication field. The communication technology which uses visible light for communication is Visible Light Communication. The visible light is what we see all around the life every day. The activities which we perform everyday relies on gathering information through our eyes. Lightings in the buildings, office appliances, road lights, traffic signals, displays and it also includes electronic home appliances such as LED TV's etc., are all examples of light communication. Now-a-days LEDs are used in most of the electronic devices. Operating characteristic of LED is fast on and off. Data can be transmitted at high speed through fast switching of LED between on and off. Problems related to infrared and radio communications are widely reduced using Visible Light Communication. The applications of VLC include Smart Lightning. Smart Building is an excellent example for VLC. Smart Lightning through VLC provides the infrastructure with illumination, data communication and control of appliances. It also reduces the power consumption and reduces wiring within the building. VLC is considered to be safe and free from hacking data. Services based on locations, Defense, Security, Aviation, Tele-health, health care, etc., are all the massive applications of Visible Light Communication. The application also includes underground communication. In the proposed project, Visible Light Communication (VLC) is the data communication technology used. The overview of the proposed system is that, the system is designed for multi-floor buildings. As the conventional radio communication technology is replaced with VLC technology, wireless interference can be greatly reduced. The developed system consists of three modules namely Parking Slot Enquiry Module, Parking Slot Monitoring Module, and Parking Slot Detector module. The Parking Slot Enquiry module is integrated in the car to send the parking query to the Parking Slot Monitoring module, which is integrated in the first floor of the parking side. The Parking Slot Detector Module, which is integrated on the second floor along with Parking Slot Monitoring module on the parking side, collects information about free parking slots and sends it to the module integrated in the car. The advantage of this system includes lower cost, reduces wireless interference, and reduces time consumption and ease to use.

## II. OBJECTIVES OF THE PROJECT

- The Visible Light Communication based Smart Parking System monitors and detects the free parking slots in the parking side and displays the detected free slots to the people who use the parking service by using the modules Parking Slot Enquiry module, Parking Slot Monitoring module and Parking Slot Detector module.
- IR Detectors are used to detect the free slots. A GSM module is also interfaced to send the free parking slot information to the mobile used by the car user. Thus, the system eliminates the time required to find out the empty parking slot and reduces fuel consumption.
- Visible Light Communication technology is used for data transmission and reception, energy consumption is also

considered to be less. The system is simple, consumes less power and reduces wireless interference

- The proposed system is suitable for multiple floor buildings, which involves data gathering from parking side modules integrated in multiple floors of the building. Parking side modules continuously collect the data and intimate the module integrated in the vehicle section. The module in the vehicle section interfaces a GSM modem to send the detected information to the user mobile. The result of the proposed system is validated in an indoor environment.

### **III. LITERATURE REVIEW**

#### **1. A PERFORMANCE ANALYSIS OF “LIGHT FIDELITY” & IT'S APPLICATION**

In today's world, the number of people suffering from various diseases are increasing, with this a doctor's capability to treat such large number of people deteriorates and also the task to monitor them regularly is painstaking. However, we can overcome this problem to a certain extent with the help of newly emerged technology of LIFI and IOT

**Published in:** 2017 International Conference on Transforming Engineering Education (ICTEE)

**DOI:** 10.1109/ICTEED.2017.8585696

**Date of Conference:** 13-16 Dec. 2017

#### **2. EFFECTIVE LIFI COMMUNICATION FOR IOT APPLICATIONS**

The need of spectrum due to the fast growth of technology in one hand and the importance of Internet of Things in another hand, made a Light Fidelity (LI-FI) as a promising technology to support the IoT in the center of attention of researchers. Communication

**Published in:** 2018 IEEE 4th International Symposium in Robotics and Manufacturing Automation (ROMA)

**DOI:** 10.1109/ROMA46407.2018.8986698

**Date of Conference:** 10-12 Dec. 2018

#### **3. APPLICATION DEVELOPMENT FOR RESERVATION BASED PARKING SLOT ALLOTMENT AND MANAGEMENT SYSTEM USING ANDROID**

Modernization is the last word for a developed community. To increase the standard of living and for better transportation means, people own vehicles. Increase vehicle in number increases the complexity of traffic and parking. Parking of motor vehicles is becoming a major problem in day-to-day life. This paper presents a design and implementation method of a smart car parking technique for less time-consuming car parking using mobile application. The system is designed to identify the empty slot automatically by a proximity sensor and to park the car at the corresponding slot for a particular time period by using RFID, GSM and ATMEGA controller.

**Published in:** 2017 International Conference on Innovations in Information, Embedded and Communication Systems (ICIIECS)

**DOI:** 10.1109/ICIIECS.2017.8275983

**Date of Conference:** 17-18 March 2017

#### **4. SMART PARKING SYSTEM FOR CARS**

Growing population in metro cities is leading to huge vehicle density, the problems for car parking has become an unending question. To avoid roadside parking and associated traffic problems centralized car parking systems are established. In this paper a centralized system is demonstrated, where in car driver is directed to select the closest traffic free path to reach the parking slot identifying the free slots. Conventional parking systems do not have any intelligent monitoring arrangement; causing wastage of time to find the slot and traffic on the way to park. Conditions are worse when there are multiple lanes and multiple parking slots

**Published in:** 2018 International Conference on Recent Innovations in Electrical, Electronics & Communication Engineering (ICRIEECE)

**DOI:** 10.1109/ICRIEECE44171.2018.9008662

**Date of Conference:** 27- 28 July 2017

#### IV. PROPOSED SYSTEM

The proposed design of smart parking system consists of a low power Arduino Uno – Atmega328 microcontroller to monitor and control the parking. To collect information about free parking slots IR detectors has to be interfaced with the Arduino Uno – Atmega328. LED's acts as Li-Fi Transmitter and Phototransistor acts as Li-Fi Receiver; which are also interfaced with the Arduino Uno – Atmega328. A GSM module is interfaced to send detected parking information to the car user. This chapter deals with the Block diagram of the project and details of each hardware component chosen in such a way that it suits best for the design of Visible Light Communication based Smart Parking System. The block diagram of the proposed system consists of three modules:

- **Parking Slot Enquiry Module**
- **Parking Slot Monitoring and Detector Module**

The module Parking Slot Enquiry module is interfaced in the car which requires parking. The modules Parking Slot Monitoring module and Parking Slot Detector module are interfaced in the parking side.

##### **Parking Slot Enquiry Module**

The Block diagram of the Parking Slot Enquiry module. Parking Slot Enquiry module is integrated on the car, to intimate the drivers about free parking slots. The module consists of an LCD to display the parking information. LED is integrated with the Arduino Uno – Atmega328 microcontroller; which acts as the transmitter. Phototransistor which acts as the receiver is also integrated with the Arduino Uno – Atmega328 microcontroller. LED transmits the data serially to the module on the parking side; whereas the phototransistor receives the data serially. Push button switch is interfaced with Microcontroller to send the query message. A GSM module is interfaced to send the detected information to the user mobile.

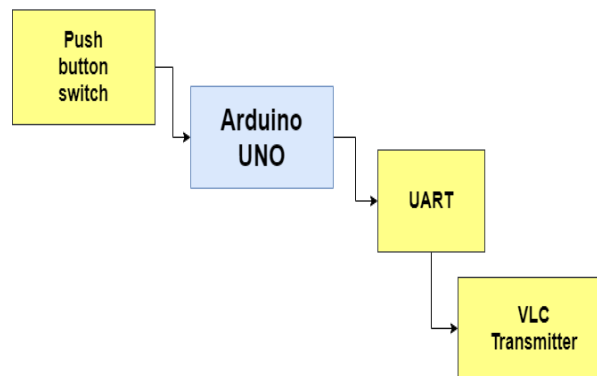

**Fig.4.1 Block diagram of Parking slot enquiry module**

##### **Parking Slot Monitoring and Detector module**

Parking Slot Monitoring and detector module is integrated on the parking side, to detect the free parking slots. The module consists of an LCD to display the parking information. LED is integrated with the ARDUINO UNO – ATMEGA328 Microcontroller. which acts as the transmitter. Phototransistor which acts as the receiver is also integrated with the ARDUINO UNO – ATMEGA328 Microcontroller. LED transmits the data serially to the module on the parking side; whereas the phototransistor receives the data serially. In this module two IR Detectors are used to detect the free parking slots. If all the Parking Slots are busy, Text is as slot full, once the slot gets free msg the user again.

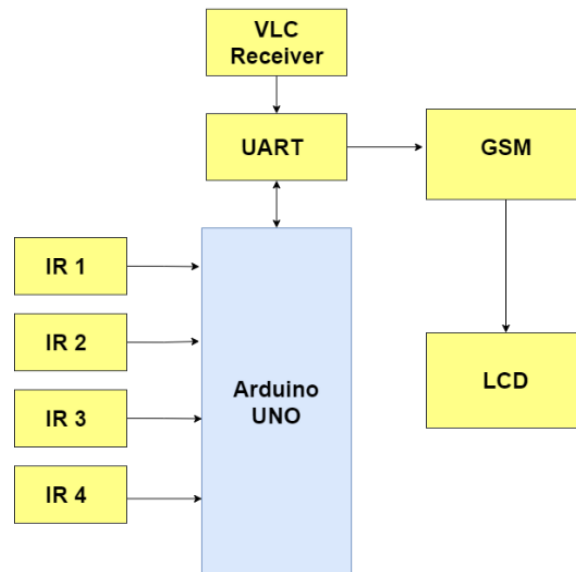

Fig.4.2 Block diagram of parking slot enquiry and detector module

**V. FLOW CHART**

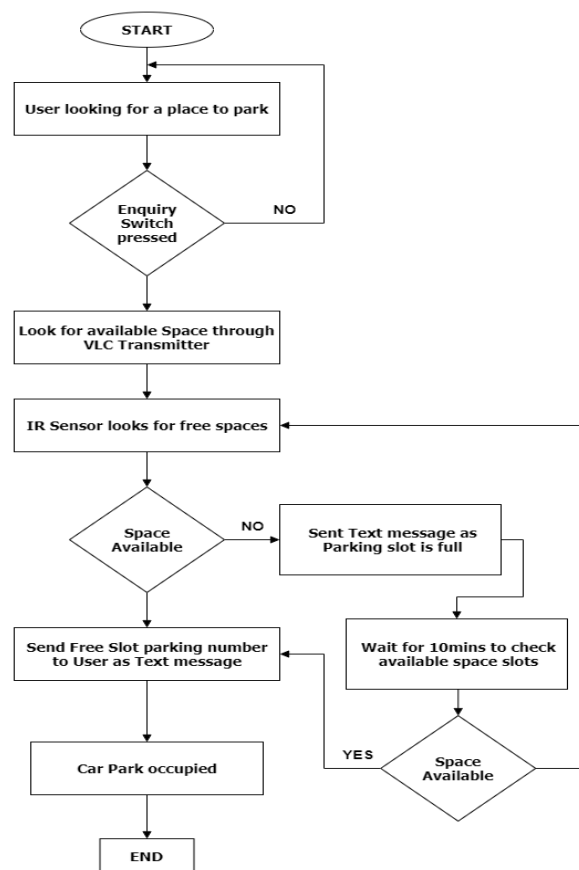

Fig. 5.1 Flow Chart

## VI. TECHNIQUES IMPLEMENTED

### LI-FI (Light Fidelity) and VLC (Visible Light Communication)

- New communication technology using Visible light.
- Visible light is only a small portion of the electromagnetic spectrum.
- Wavelength between 380nm (750 THz) to 750nm (428 THz).

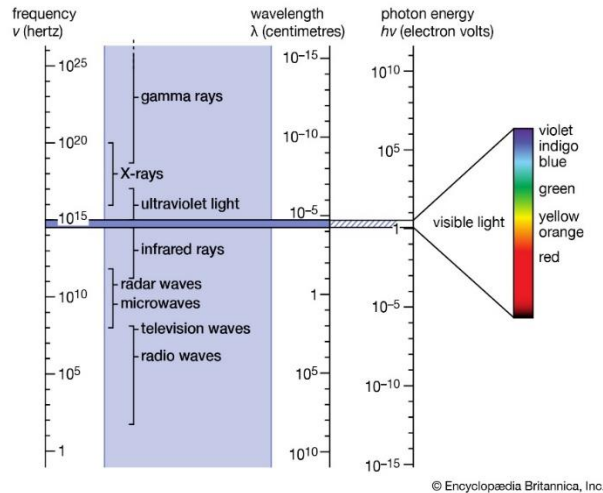

Fig.6.1 Electromagnetic Spectrum

### Why we using LI-FI instead of WI-FI??:

- It does not cause any health problems.
- No EM-interference.
- It is free.
- Fast switching.
- faster transmission of data and faster internet connections – about 100 times faster than speeds achievable by **Wi-Fi**.

### TECHNOLOGY:

#### TRANSMITTERS

- Theoretically every kind of light source can be used as transmitting device.
- More promising alternatives are fluorescent lights and LEDs.
- LEDs are the predominant choice for transmitters.

#### RECEIVERS:

- Photodiode receivers.
- CCD and CMOS sensors

#### DATA RATES ACHIEVED:

- Phosphorus LEDs can achieve up to 40 Mbps.
- By using RGB LEDs data rates can go up to 100 Mbps.
- RCLEDs (Resonant Cavity LEDs) can achieve data rates up to 500 Mbps.
- RCLEDs use Bragg reflectors to enhance the emitted light.
- Increased spectral purity when compared to conventional LEDs.

**MODULATION:**

- Modulation is used to transform the data (given as a sequence of 0s and 1s) into a series of light pulses.
- Two main alternative modulation schemes:
  1. Pulse Position Modulation (PPM) :
    - Amplitude & width of pulse is constant.
  2. Frequency Shift Keying (FSK):
    - Digital information is transmitted through frequency changes of carrier wave.

**APPLICATIONS:**

- Smart Home Network
- Commercial Aviation
- Hazardous Environments
- Hospital and Healthcare

**VII. HARDWARE IMPLEMENTATION****1. Arduino UNO****Fig.7.1 Arduino UNO**

The Arduino Uno is an open-source microcontroller board based on the Microchip ATmega328P microcontroller and developed by Arduino.cc. The board is equipped with sets of digital and analog input/output (I/O) pins that may be interfaced to various expansion boards (shields) and other circuits. The board has 14 digital I/O pins (six capable of PWM output), 6 analog I/O pins, and is programmable with the Arduino IDE (Integrated Development Environment), via a type B USB cable. It can be powered by the USB cable or by an external 9-volt battery, though it accepts voltages between 7 and 20 volts

**2. LCD Display****Fig.7.2 LCD Display**

LCD is a flat –panel display or other electronically modulated optical device that uses the light –modulating properties of liquid crystals combined with polarizers. A 16x2 LCD means it can display 16 characters per line and there are 2 such lines. In this LCD each character is displayed in 5x7 pixel matrix. The 16 x 2 intelligent alphanumeric dot matrix display is capable of displaying 224 different characters and symbols.



### 3. Push Button Switch



**Fig.7.3 Push Button Switch**

A push button switch is a small, sealed mechanism that completes an electric circuit when you press on it. When it's on, a small metal spring inside makes contact with two wires, allowing electricity to flow. When it's off, the spring retracts, contact is interrupted, and current won't flow.

### 4. Step Down Transformer

#### i. Step down voltage level



**Fig.7.4 Step-down Transformer**

The step-down converters are used for converting the high voltage into low voltage. The converter with output voltage less than the input voltage is called as a step-down converter, and the converter with output voltage greater than the input voltage is called as step-up converter. There are step-up and step-down transformers which are used to step up or step down the voltage levels. 230V AC is converted into 12V AC using a step-down transformer. 12V output of stepdown transformer is an RMS value and its peak value is given by the product of square root of two with RMS value, which is approximately 17V. Step-down transformer consists of two windings, namely primary and secondary windings where primary can be designed using a less-gauge wire with more number of turns as it is used for carrying low-current high-voltage power, and the secondary winding using a high-gauge wire with less number of turns as it is used for carrying high-current low-voltage power. Transformers works on the principle of Faraday's laws of electromagnetic induction. Step-down transformer consists of two windings, namely primary and secondary windings where primary can be designed using a less-gauge wire with a greater number of turns as it is used for carrying low-current high-voltage power, and the secondary winding using a high-gauge wire with a smaller number of turns as it is used for carrying high-current low-voltage power. Transformers works on the principle of Faraday's laws of electromagnetic induction.

#### ii. Convert AC to DC

230V AC power is converted into 12V AC (12V RMS value wherein the peak value is around 17V), but the required power is 5V DC; for this purpose, 17V AC power must be primarily converted into DC power then it can be stepped down to the 5V DC. But first and foremost, we must know how to convert AC to DC? AC power can be converted into DC using one of the power electronic converters called as Rectifier. There are different types of rectifiers, such as half-wave rectifier, full-wave rectifier and bridge rectifier. Due to the advantages of the bridge rectifier over the half and full wave rectifier, the bridge rectifier is frequently used for converting AC to DC. Bridge rectifier consists of four diodes which are connected in the form a bridge. We know that the diode is an uncontrolled rectifier which will conduct only forward bias and will not conduct during the reverse bias. If the diode anode voltage is greater than the cathode voltage then the diode is said to be in forward bias. During positive half cycle, diodes D2 and D4 will conduct and during negative

half cycle diodes D1 and D3 will conduct. Thus, AC is converted into DC; here the obtained is not a pure DC as it consists of pulses. Hence, it is called as pulsating DC power.

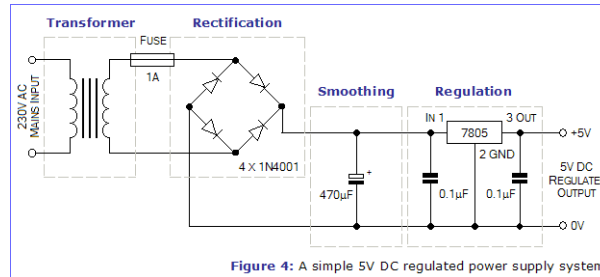

Fig.7.5 Bridge Rectifier

## 5. VLC Transmitter and Receiver

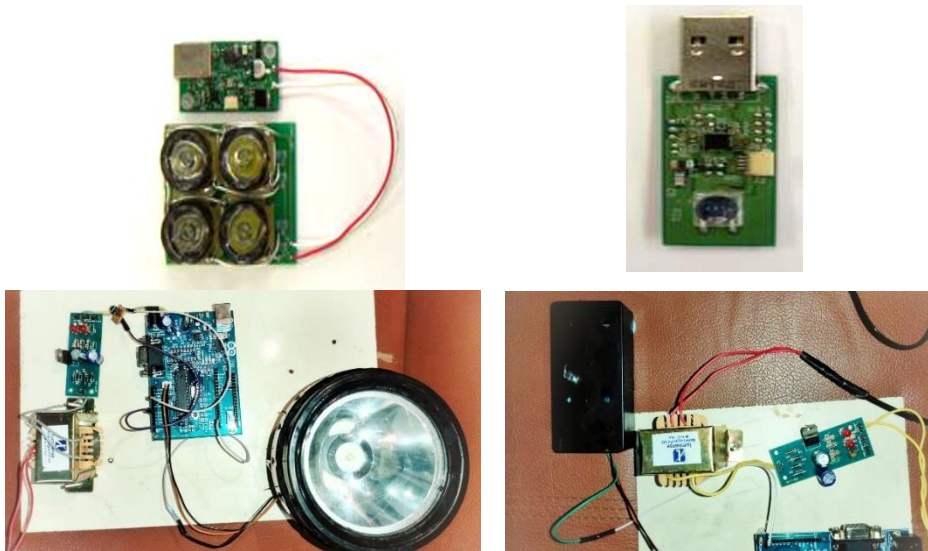

Fig.7.6 Transmitter

Fig.7.7 Receiver

### TRANSMITTERS:

- Theoretically every kind of light source can be used as transmitting device.
- More promising alternatives are fluorescent lights and LEDs.
- LEDs are the predominant choice for transmitters.

### RECEIVERS:

- Photodiode receivers.
- CCD and CMOS sensors.



## 6. IR Sensor



**Fig7.7 IR Sensor**

Infrared (IR) light is electromagnetic radiation with a wavelength longer than that of visible light, measured from the nominal edge of visible red light at 0.7 micrometers, and extending conventionally to 300 micrometers

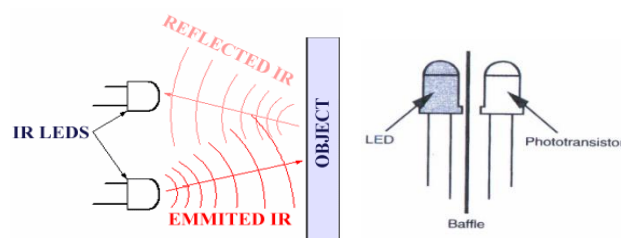

**Fig 7.9 IR Circuit Diagram**

These wavelengths correspond to a frequency range of approximately 430 to 1 THz, and include most of the thermal radiation emitted by objects near room temperature. Microscopically, IR light is typically emitted or absorbed by molecules when they change their rotational-vibrational movements.

Sunlight at zenith provides an irradiance of just over 1 kilowatt per square meter at sea level. Of this energy, 527 watts is infrared radiation, 445 watts is visible, and 32 watts is ultraviolet radiation

## 7. GSM Modem



**Fig.7.10 GSM Modem SIM 800C**

The GSM system is the most widely used cellular technology in use in the world today. Global System for Mobile Communications was designed as a second generation (2G) cellular phone technology by using a digital TDMA (time division multiple access approach).

GSM cellular technology uses 200 kHz RF channels. These are time division multiplexed to enable up to eight users to access each carrier. In this way it is a TDMA / FDMA system.

## VIII. SOFTWARE IMPLEMENTATION

### SOFTWARE

The open-source Arduino Software (IDE) makes it easy to write code and upload it to the board. This software can be used with any Arduino board.

### ALGORITHM

#### 1. Transmitter side: Switch – LI-FI Transmitter

**Step 1:** Include the required header files.

**Step 2:** Initialize an analog pin for Sensor and Potentiometer.

**Step 3:** Analog input pin A0 and A1 is attached Potentiometer.

**Step 4:** Sensor A5 pin is selected for the input of the potentiometer. Sensor value 0 is selected for variable to store the value coming from the sensor.

**Step 5:** Set the corresponding Pins to input and output. Pin 11 and 12 are set for output and pin A0, 2, 3 are set for Input pullup.

**Step 6:** Digital read pin read the value from switch and Transmit the data to LI-FI receiver.

#### 2. Receiver side: LI-FI Receiver-IR4-GSM

**Step 1:** Include the required header files.

**Step 2:** Initialize an analog pin for Sensor and Potentiometer.

**Step 3:** Analog input pin A0 and A1 is attached to Potentiometer.

**Step 4:** Initialize a variable to hold the data. Sensor Pin A5 is the input of the potentiometer and sensor values are set to 0. To store the value coming from the sensor.

**Step 5:** Set the corresponding pins to Input and Output. Pin 7,6,5,4 is input and Pin 2 is the output.

**Step 6:** Initialize the LCD module.

**Step 7:** Read the data from the analog and store it in the variable.

**Step 8:** Send the data to the LCD and user's mobile number.

## IX. EXPERIMENTAL RESULTS

The Visible Light Communication based Smart Parking System consists of three modules namely Parking Slot Enquiry module, Parking Slot Monitoring module and Parking Slot Detector module. Each module consists of an Arduino Uno – At mega32 Microcontroller, powered by 12V supply voltage. A 16x2 LCD display unit is interfaced with the three modules to display the corresponding results. In the developed system LEDs are interfaced to transmit the requested data; whereas phototransistors are interfaced to receive the transmitted data.

### Hardware Setup

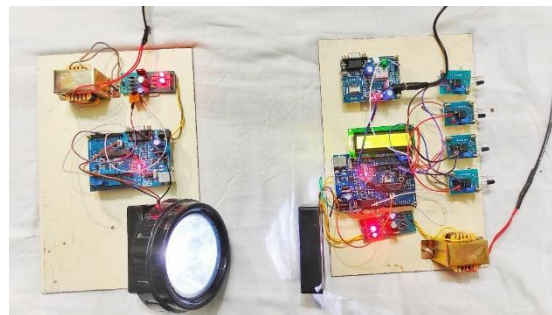

**Fig.9.1 Hardware Setup**

In this Hardware Setup, there are two modules: one is the transmitter module and the other is the receiver module. The transmitter module is integrated with the user's car's beam, and the receiver module is fixed in the parking location. The LI-FI Receiver is fixed in the parking entry to receive enquiry messages from the LI-FI Transmitter.

### Transmitter Module – (Integrated with Car’s beam)

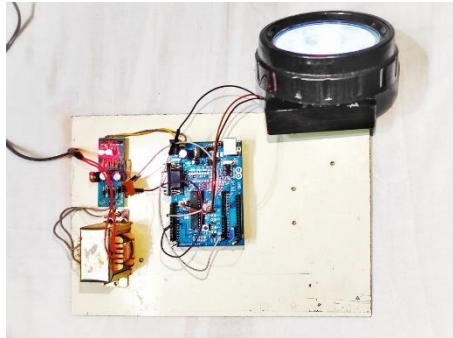

Fig.9.2 Transmitter module

### Receiver Module – (Integrated with parking location)

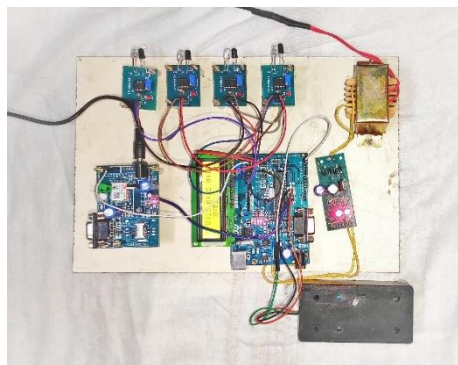

Fig.9.3 Receiver module

### Parking slot empty condition



Fig.9.4 Parking slot empty condition

In this condition, the IR Detector detects that all the parking slots in both the floors are empty. In the proposed system two parking slots are considered in both first floor and second floor. Each parking slot is provided with an IR Detector. If the signal between the IR transmitter and IR receiver is cut down, then it is assumed that a car is parked in that particular slot. The parking slots are free in both the floors.

### One parking slot is free

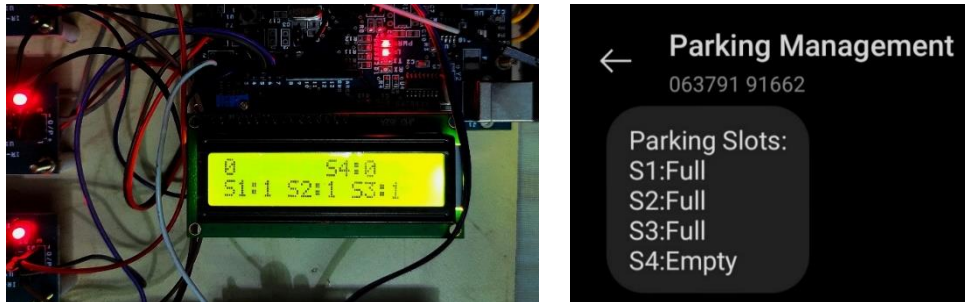

**Fig.9.5 One parking slot is free**

In this condition, the IR Detector detects that one parking slot in both the floors are empty. In the proposed system two parking slots are considered in both first floor and second floor. Each parking slot is been provided with an IR Detector. If the signal between the IR transmitter and IR receiver is cut down, then it is assumed that a car is parked in that particular slot. In this condition one parking slot in both the floors.

### Parking slot is full

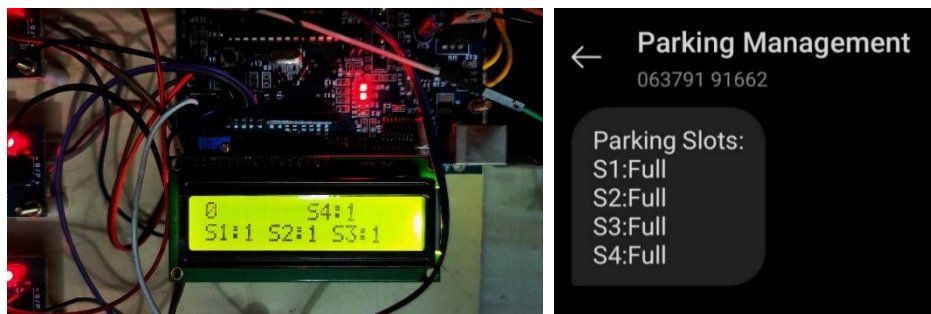

**Fig.9.6 Parking is full**

In this condition, if all the slot are busy, text it as slot full, Once get free message the user again. the IR Detector detects that no parking slot in both the floors are empty. In the proposed system two parking slots are considered in both first floor and second floor. Each parking slot is been provided with an IR Detector. If the signal between the IR transmitter and IR receiver is cut down, then it is assumed that a car is parked in that particular slot.

### GSM Modem Initialization

The GSM Modem SIM 800C initialization setup. The SIM800 C, a GSM modem is initialized through the AT Commands through software.



**Fig.9.7 GSM Modem Initialization**

The SIM slot is provided with four pins which are designed to be connected to the GSM module. The different pins are connected to SIM\_RST, SIM\_VDD, SIM\_DATA and SIM\_CLK. SIM\_VDD is the voltage supply for the SIM card which supports 1.8V or 3V SIM card. SIM\_DATA is used for data input/output.



**Fig.9.8 GSM Module SIM800 C**

### Message Sent to the phone

The parking slots detected through IR Detectors is sent to the mobile phone through GSM. The message received in the mobile phone.

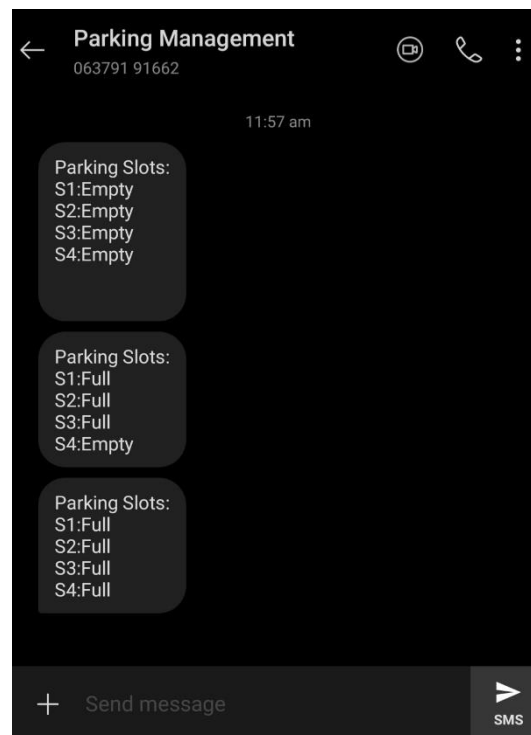

**Fig.9.9 Parking slot details message received in the user mobile**



## X. FUTURE WORK

As Visible Light Communication based Smart Parking System uses only single LED and phototransistor to transmit and receive data serially, the proposed system requires line-of-sight between LED and phototransistor. In future, the system can be implemented by using the readily market available LED bulbs which can be driven to transmit data; and also, these LED bulbs acts as the lightning system. We can also the GPS in the parking slot to direct the drivers to the parking slot location. These LED's bulbs can be interfaced to enhance the data transmission at faster rate to enable users to communicate anytime and anywhere in safer manner. Apart from these LED bulbs, power LED's can also be used. The work can also be extended by providing direction map to the available free slots. Payment for parking can also be added by automating the payment through IOT via integrating the bank details. IOT can also be used to control the IR Detectors and maintain a database of parking slots.

## XI. CONCLUSION

Thus, the Visible Light Communication based Smart Parking System monitors and detects the free parking slots in the parking side and displays the detected free slots to the people who use the parking service by using the modules Parking Slot Enquiry module, Parking Slot Monitoring module and Parking Slot Detector module. IR Detectors are used to detect the free slots. A GSM module is also interfaced to send the free parking slot information to the mobile used by the car user. Thus, the system eliminates the time required to find out the empty parking slot and reduces fuel consumption. As Visible Light Communication technology is used for data transmission and reception, energy consumption is also considered to be less. The system is simple, consumes less power and reduces wireless interference.

## REFERENCES

- [1] Emmanuel Ifada, Nasir Faruk, A. Abdulkarim (2019), "Implementation of a Data Transmission System using LI-FI Technology" Conference paper – October 2019, DOI: 10.1109/NigeriaComputConf45674.2019.8949659.
- [2] Manjusha Patil, Vasant N. Bhonge (2018), "Wireless Sensor Network and RFID for Smart Parking System" International Journal of Emerging Technology and Advanced Engineering, ISSN 2250- 2459, Vol. 3, Issue 4
- [3] Mohit Patil and Rahul Sakore (2019), "Smart Parking System Based on Reservation" International Journal Of Scientific Engineering and Research, ISSN (Online): 2347-3878, Vol. 2, Issue 6
- [4] Vanessa W.S. Tang, Yuan Zheng and Jiannong Cao (2019), "An Intelligent Car Park Management System based on Wireless Sensor Networks" 1st International Symposium on Pervasive Computing and Applications, Vol.4,
- [5] Soh Chun Khang, Teoh Jie Hong, Tan Saw Chin and Shengqiong (2019), "Wireless Mobile-based Shopping Mall Car Parking System (WMCPS)" IEEE Asia-Pacific Services Computing Conference, 978-0-7695-4305-5/10 \$25.00 © 2019 IEEE, DOI 10.1109/APSCC.2010.116
- [6] Shweta Sagar, Deeksha Lal and Seema Dahiya (2018) "Visible Light Communication" International Journal of Engineering Research and Development, e-ISSN: 2278-067X, p-ISSN: 2278-800X, Volume 11, Issue 01 (January 2018), PP.36-40
- [7] M.F. Ismail, M.O. Reza, A.A. Rokoni and M.A.R. Sarkar (2019), "Design and Development of an Advanced Vehicle Parking System" IEEE/OSA/IAPR International Conference on Informatics, Electronics & Vision, 978-1-4673-1154- 0112/\$31.00 ©2012 IEEE
- [8] John E. Gancarz, Hany Elgala and Thomas D.C. Little (2019) "Overlapping PPM for band-limited visible light communication and dimming", Journal of Solid-State Lighting (2019) 2:3, DOI 10.1186/s40539- 015-0022-0
- [9] Carlos Medina, Mayteé Zambrano and Kiara Navarro (2018), "Led Based Visible Light Communication: Technology, Applications and Challenges –A Survey", International Journal of Advances in Engineering & technology, ISSN: 22311963