

Integrated Systems for Distributed Generation Sources

Mr. Dhananjay V. Pawar¹, Sandip V. Pokharkar², Sagar N. Datkhile³, Nikhil M. Kunjir⁴

Lecturer, Department of Electrical Engineering, Bhivrabai Sawant Polytechnic, Pune, India^{1,2,3,4}

Abstract: Compact integrated system is proposed in this paper. Local energy system, load and storage devices are available on DG unit. These DG units are having their own power converter for grid interfacing. If no. of DG units increases then no. of power converter is increases. In this power converter we are using power electronics devices such as MOSFETS, IGBT, Diodes. So, no. of power devices increases switching losses, heating losses increases. THD of the system, cost increases. so, in this paper this all DG units combine together and new circuit topology is designed so that reduction in power devices, cost. In this method less THD getting in results. This paper is designed by using tool MATLAB-SIMULINK. Laboratory.

Keywords: Distributed generation (DG), Battery, Ultra-capacitor , grid , Inverters.

I. INTRODUCTION

The renewable energy sources are having the more importance worldwide. Day by day its demand gets increases it is popular in country because it is one useful for the nature and harmless. To store the energy we use the batteries and Capacitors as well. For smoothing in DC source small DG sources are used. We did not get continuous supply form these sources. To get maximum Control, we can't avoid the energy storage devices but we will reduce their capacity to get maximum control we having very less Storage devices and we can't sure for their capacity also we just take the example if we combine the capacitor and battery for provide the relevant power This energy source is not one system which is source It having many things to get and compete the requirement of local, storages and grid requirement. These things having their own Converters .This power converter process this energy and store in storage systems. But in this entities we need more no of power converter so cost of the system increases. If we consider about renewable sources, those energy generations are usually intermittent. Power converter for renewable energy sources operate below their capacity for period of time. So we need integration between renewable source and storage device. In paper power converters are used having 25% lesser power devices. This system is having the advantages are proposed as well as the operating principals.

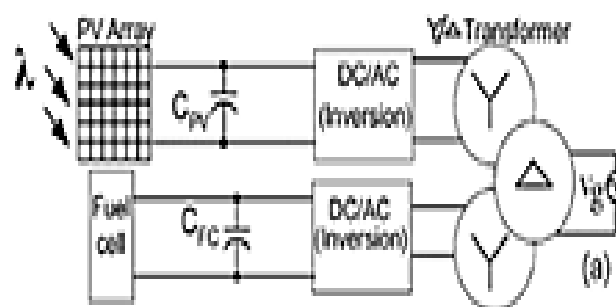

Fig.1 Conventional Topology for Two Multistage Inverters

II. NONINTEGRATED ENERGY SYSTEM

In Fig. 2 circuit diagram of nonintegrated system .In this diagram solar panel as renewable source we have used .But solar panel having variable output it depends on Weather condition. So for getting constant dc output we are using DC-DC converter .Output of DC-DC converter we are giving to three phase inverter and output of inverter is fed to grid. As well as for charging batteries, ultra capacitor we need DC-DC charge controller. In this converter and Inverter part power electronics devices such as MOSFET are used. Due to more no. of semiconductor devices switching losses, heating losses increases. More no of semiconductor devices more no of harmonics and losses as well as cost of the system increases. So for overcome above problem compact integrated system is proposed in this paper.

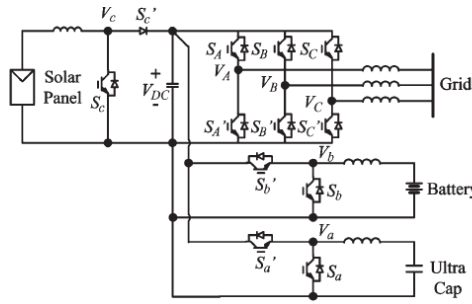

Fig.2 Example circuit layout of nonintegrated energy system.

2.1 Method of Integration

Non integrated system itself explains for integrated system .Fig no 3 shows circuit diagram of integrated system. In this diagram Inverter, input DC source, Grid, solar panel, ultra capacitor, Battery are highly interconnected with each other. In conventional method more no of semiconducting devices are used but in this proposed system less no PF power electronics devices are used for grid interconnection as well as for other DG sources. So that overall efficiency of system is increased. Due to less devices harmonics also reduced and cost of the system is minimized.

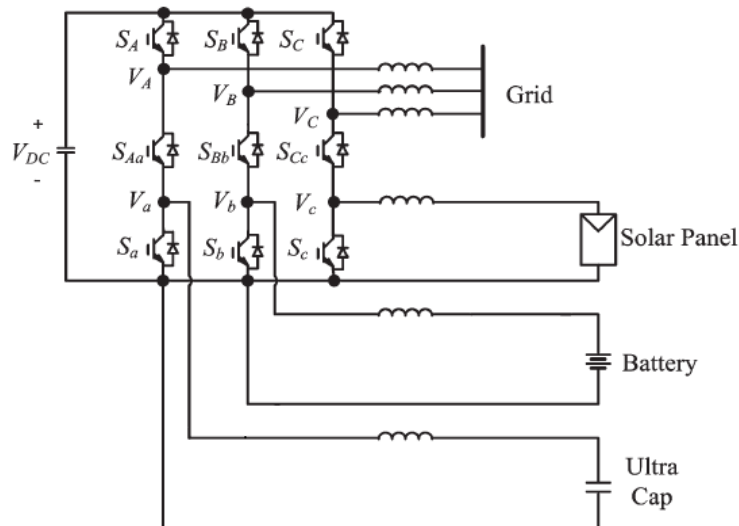

Fig. 3. Three phase Inverter having various Sources and Energy storage device

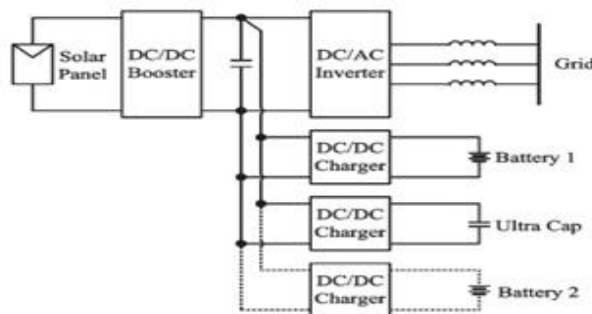

Fig.4 Block diagram of nonintegrated energy system

III.PV MODULE CHARACTERISTIC

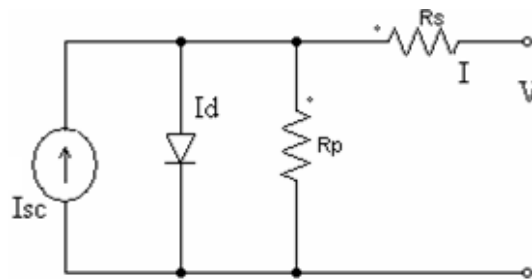

Fig. 5 Equivalent circuit diagram of a solar cell PV module

The equivalent circuit diagram of an PV module is shown in fig.5. The current source represents the current generated by light photons and its output is constant under constant temperature and constant irradiance. The diode shunt-ed with the current source determines the characteristics of I-V of an solar cell. There is a series of resistance in a current path through the semiconductor material, the metal grid, contacts, and a current collecting bus. These resistive losses are lumped together as a series resistor (R_s). Its effect becomes very noteworthy in a PV module. The loss associated with a small leakage of current through a resistive path in parallel with the intrinsic device is represented by a parallel resistor (R_p). Its effect is much less noteworthy in a PV module compared to the series resistance, and it will only become noticeable when a number of PV modules are connected in parallel for a larger system. The characteristic equation which represents the I-V characteristic of a practical photovoltaic module is given below

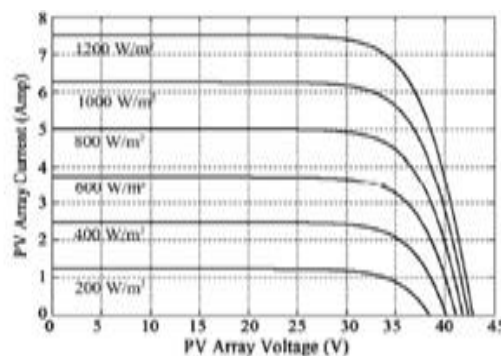

Fig.6 I-V characteristics of the solar PV array

3.1 Modulation Principles

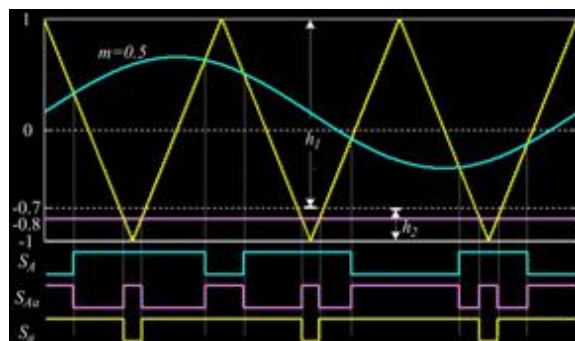

Fig. 7. Carrier and reference signal.

Fig no.7 Above circuit diagram shows phase leg connected to dc terminal is modulated using dc reference and triangular wave. Inverter phase leg connected to AC grid which is three phase is controller using sinusoidal and triangular signal. In Carrier signal two phases not are same but one carrier wave involving in one timer. So its advantage that using only one carrier signal and different reference signal shows in below.

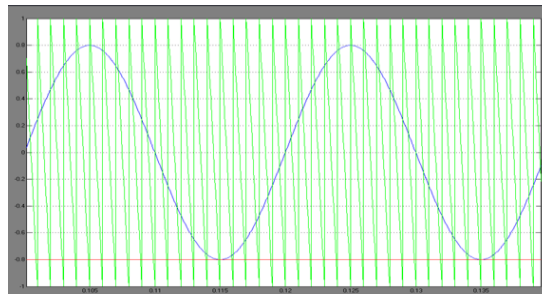

Fig .8 Single phase sinusoidal reference signal

Sinusoidal reference signal is always placed above linear reference for upper switch for avoiding problems for lower switch.restricted state of $V_A = 0\text{ V}$ and $V_a = V_{dc}$.in Fig. 7 we can see the modulation of three switches , carrier signal is divided in to h1 and h2.the upper band h1 is for upper terminal and it confirm the sinusoidal reference. Same for the h2 which is lower band and hence it confines the linear reference. Now the comparison of signals with carrier wave we are getting switching pulses to trigger MOSFET

$$\begin{aligned} SA &= 1, \text{ reference} \geq \text{carrier} \\ SA &= 0, \text{ reference} < \text{carrier} \end{aligned} \tag{1}$$

$$\begin{aligned} Sa &= 0, \text{ reference} \geq \text{carrier} \\ Sa &= 1, \text{ reference} < \text{carrier} \\ SAA &= SA \oplus Sa - (!SA) \oplus (!Sa) \end{aligned} \tag{2}$$

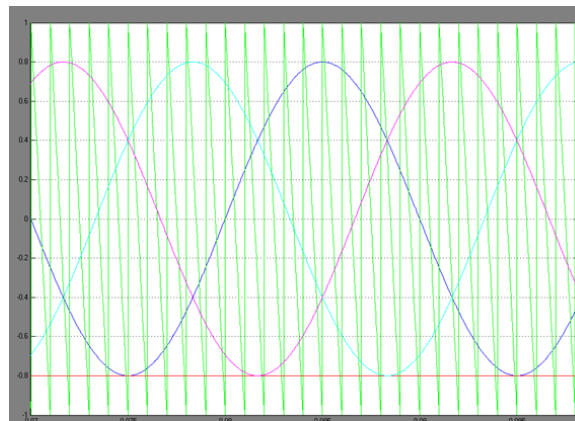

Fig.9 Three phase sinusoidal reference signal

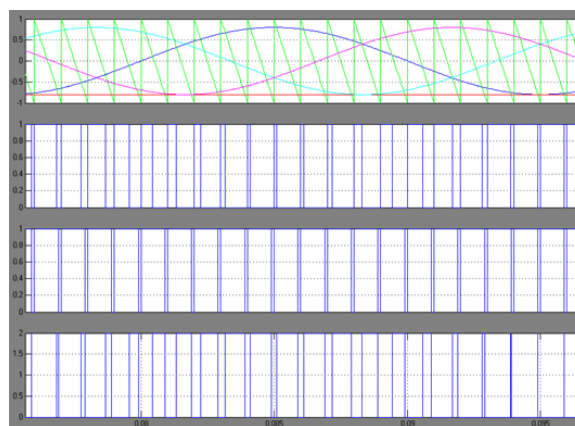

Fig.10 shows pulse pattern for switches.

3.2. Parameters and Constraints

The lower band h_2 is associated with lower terminal switch and it is connected to the dc source. The important thing for it is duty ratio for the switch. The range of variation of d and its accompanied gain

$$G_{dc} = (1/(1 - d))$$

$$(1 - 0.5h_2) \leq d \leq 1 \quad 2/h_2 \leq G_{dc} < \infty. \quad (3)$$

for interconnected DC source to the grid G_{dc} much me large. hence we have to remove the storage devices in series. And some entities are in the series, The overall system is hence simplified, having the reason behind it to keep h_2 small and G_{dc} high. Now in upper terminal band h_1 .upper terminal switch is connected to the AC grid. Its important parameter is modulation index indicates amplitude of sinusoidal signal which resulting buck gain G_{ac} . It's value is vary where the factor of 1.15 is added for representing triple insertion.

$$0 \leq M \leq 1.15 \times \frac{h_1}{2}. \quad (4)$$

The value of M is inversely proportional to the dc-link voltage

$$V_{dc}(M \propto 1/V_{dc}) \quad (5)$$

h_1 is high for lowering V_{dc} which is A_c , require M for the lowering the V_{dc} . That means $h_2 = 2 - h_1$ is low, for the proposed system, is fine hence we need G_{dc} is high gain . For the three switch method our Proposed system is Compatible which we can see in Fig. 2) In those references, V_{dc} is doubled because M is set to a maximum of only 0.5.

IV. CONTROL PRINCIPLES

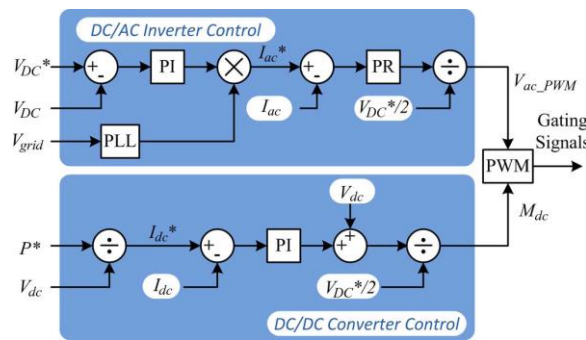

Fig.11 control principle for the integrated system controller

Fig.11 shows the control principle for the integrated system controller is designed for dc-ac converter. In fig 11 actual V_{dc} is compare with reference V_{dc}^* and the regulated output is given to the PI controller. proportional (P)-integral (I) The inner current loop, getting very quick as well as fast, which is replaced by a low-pass-filter and time lap shows the delay and capacitor charging dynamics. The P and I gains are then chosen as $K_{p1} = 0.1$ and $K_{i1} = 10$ to give enough phase margin for maintaining the overall system stability. Output of PI controller is getting current For maintaining constant DC.

$$I_m = K_p(V_{dcerror}) + K_i(V_{dcerror}) \quad (6)$$

This I_m is multiply with the sine synchronized signal. When we pass grid voltage through PLL we are getting synchronized signal. That sine signal multiply with I_m we are getting reference current I_{ac}^* . The reference signal I_{ac}^* is then fed with inner current loop and it compare with the actual AC. the error current is passed through PR controller. A P-resonant (PR) controller is used instead, whose transfer expression is written as

$$GPR(s) = K_{p2} + 2K_{i2}\omega_c s^2 + 2\omega_c s + \omega_c^2 \quad (7)$$

ω_c and ω_o are the cutoff of the fundamental frequencies, K_{p2} and K_{i2} gains of controller. The signal is first design the proper PR controller and then make the ac modulating reference for the fig. 3 we need generate switching pulse. for this timer counting is from 0 to 1 and back is used for triangular carrier, We can see in Fig. 3. The ac modulating reference should therefore be changed, whose effect is still to place the reference centrally within the upper sub band

$$h_1 V_{ac_PWM} = 0.5 V_{ac_PWM} h_1 + 1 - 0.5 h_1 \quad (8)$$

Now attention goes towards lower switch for dc-dc converter.. In this case power reference signal is created from storage device. For ex. In case of PV panel power references is created using MPPT. The calculated power reference signal is then compare with actual input voltage to generate current reference signal I_{dc} . then error voltage again passed through PI, with dc gain is use to force the steady state error. In the MATLAB we can develop the PI Controller. We

get the The final parameters are $Kp3 = 0.301$ and $Ki3 = 2131$. Here V_{dc} is the added with the output of the PI controller. then output is then divided with $V_{dc}/2$, for generate the M_{dc} is the dc modulating reference. As per Fig. M_{dc} , which placed to the lower sub band $h2$. There is for M_{dc} no dc offset needs to be added, unlike the ac reference V_{ac_PWM} . The above controller gives steady state response. To get source current is in very quick manner, The time of the lowest switch is Short, We can say from (1) and Fig. 4, needs the dc modulating reference M_{dc} to increase. For the Integrated Energy system The amount by which M_{dc} can increase is however limited to $h2$. The transient state Slow response is not experienced to increase in current, which based on the reverse reasoning, it requires the on time of the lowest switch to be lengthened. according to Fig. 4, it require lower modulating reference which do not have the restriction by the integrated system. The disadvantage is that the current is decrease of the integrated system. It's impact is not powerful when compare with maximum power point tracking, Storage Charging ,discharging also. Our proposed technique is more convincing as compare to the Nonintegrated counter part.

V. MATLAB SIMULATION

Fig. no 12 shows simulation diagram for integrated system. In this diagram we have used DC source with 350v .this dc source is fed with dc link capacitor having value 2200uf .Output of dc source is connected to power converter .we have used MOSFET as power electronic device .we need total 9 MOSFETS .Output of power converter is fed to the grid having voltage as155v ,50hz.Two dc sources is used in this paper and 1 dc load .we design non integrated and integrated model in MATLAB and results analysis is done.

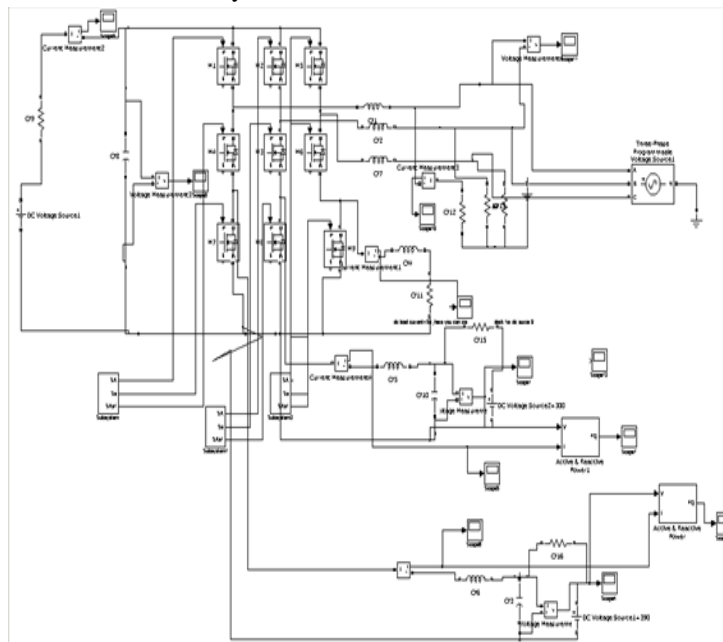

Fig.12simulation diagram for integrated system

From the model we analyze results of grid voltage ,grid current ,dc link voltage ,power of dc source 1 ,power of dc source 2 and dc load current. THD analysis is done for grid voltage and grid current.

VI.PARAMETER

Vdc	350v
Cdc	2000uf
Lf	5mh
Rf	20ohm
Rdc	7ohm
Ldc	1mh
Vdc1,Vdc2	50v
Cdc1,Cdc2	2200uf
Ldc1,Ldc2	5mh
Vgrid	155v
Fsw	10khz

VII.RESULTS

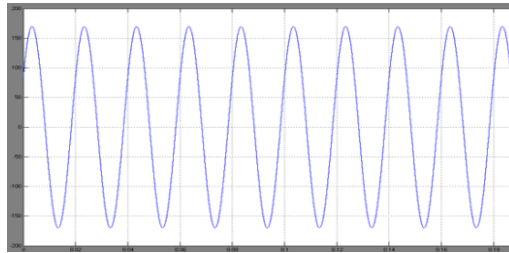

Fig.13 Grid voltage

Fig.13 is Shown the results for the grid voltage it is come nearly up to 155V as per the Table .

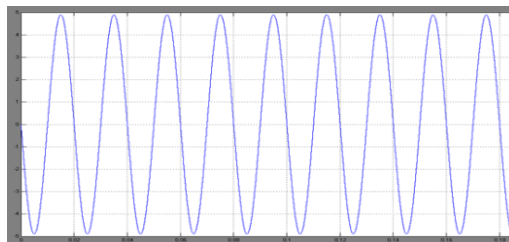

Fig.14 grid current

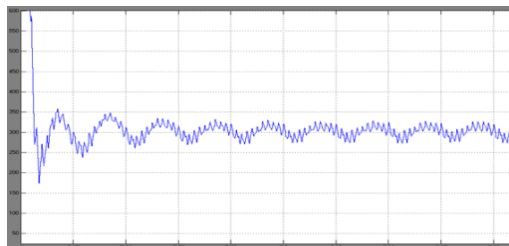

Fig15.dc link vaoltge

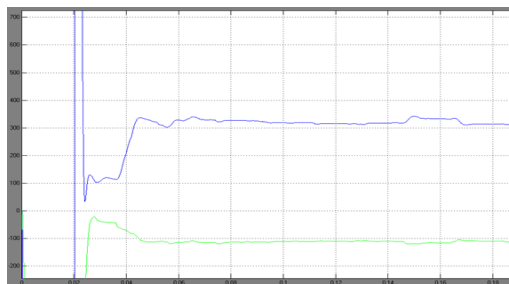

Fig16 .dc 1 source power

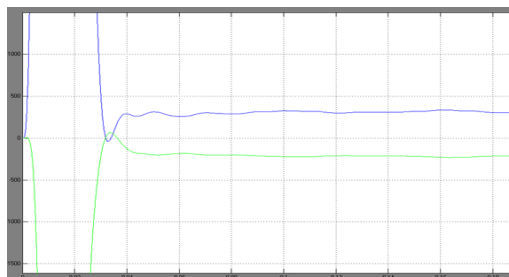

Fig17 dc 2 source power

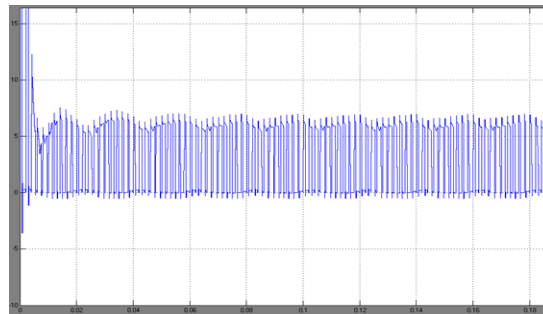

Fig.18 dc load current

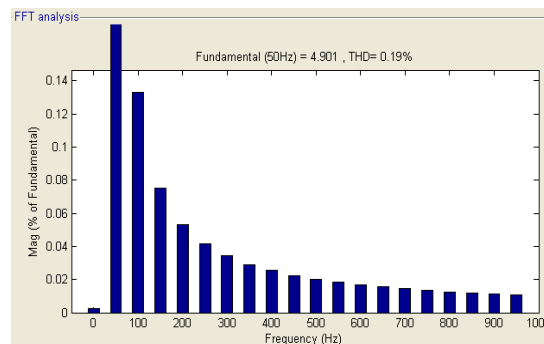

Fig19 grid current THD

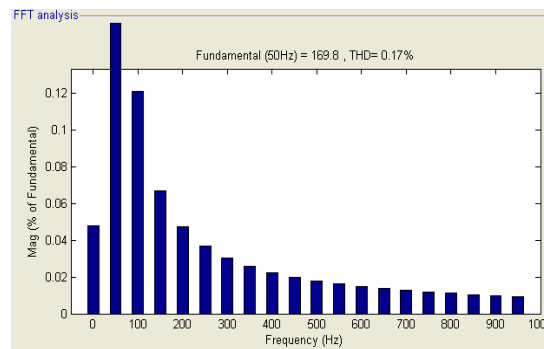

Fig.20 grid voltage THD

VIII.CONCLUSION

This paper is based on number of integrated compact system which are based on topology of Converter. From analysis in MATLAB we can conclude that we need lesser semiconducting devices so as to cost of the system is reduced and increase the efficiency. By using proper modulation technique, we can minimize some problems. We are getting less THD in grid voltage and grid current. steady state power we are getting from dc sources.

REFERENCES

- [1]. W. Li, G. Joos, and J. Belanger, "Real-time simulation of a wind turbine generator coupled with a battery supercapacitor energy storage system," *IEEE Trans. Ind. Electron.*, vol. 57, no. 4, pp. 1137–1145, Apr. 2010
- [2]. Cimuca, G.O.; Saudemont, C.; Robyns, B.; Radulescu, M.M.; , "Control and Performance Evaluation of a Flywheel Energy-Storage System Associated to a Variable-Speed Wind Generator," *Industrial Electronics, IEEE Transactions on* , vol.53, no.4, pp.1074-1085, June 2006.
- [3]. Chiang, S.J.; Chang, K.T.; Yen, C.Y.; , "Residential photovoltaic energy storage system," *Industrial Electronics, IEEE Transactions on* , vol.45, no.3, pp.385-394, Jun 1998.
- [4]. Vazquez, S.; Lukic, S.M.; Galvan, E.; Franquelo, L.G.; Carrasco, J.M.; , "Energy Storage Systems for Transport and Grid Applications," *Industrial Electronics, IEEE Transactions on* , vol.57, no.12, pp.3881-3895, Dec. 2010.
- [5]. Chunhua Liu; Chau, K.T.; Xiaodong Zhang; , "An Efficient Wind-Photovoltaic Hybrid Generation System Using Doubly Excited Permanent-Magnet Brushless Machine," *Industrial Electronics, IEEE Transactions on* , vol.57, no.3, pp.831-839, March 2010 .
- [6]. Barton, J.P.; Infield, D.G.; , "Energy storage and its use with intermittent renewable energy," *Energy Conversion, IEEE Transactions on* , vol.19, no.2, pp. 441- 448, June 2004.