

# BER Reduction in OFDM with Different Modulation and Encoding Schemes

Mohd. Ajaz Iqbal<sup>1</sup>, Maninder Singh<sup>2</sup>

M. Tech., Student, ECE Department, Haryana Engineering College, Jagadhri, Haryana, India<sup>1</sup>

Assistant Professor, ECE Department, Haryana Engineering College, Jagadhri, Haryana, India<sup>2</sup>

**Abstract:** OFDM is one of the most developing technologies in modern mobile communication. OFDM is a parallel transmission scheme, where a high – rate serial data stream is split up into a set of low – rate sub streams, each of which is modulated on a separate subcarrier. Increasing the number of parallel transmission reduces the data rate that each individual carrier must convey and that lengthens the symbol period. In present communication systems, increasing the number of users reduces the data rate that each individual carrier must convey and that lengthens the symbol period. Hence, a performance comparison of OFDM system in multipath fading and additive white Gaussian noise channels is presented. The comparison proceeds in two steps. First, design simple OFDM system. Second, a binary modulating signal is transmitted over the system and the bit error rate in multipath fading and additive white Gaussian noise channels is observed. Then first compare the performance of different modulation schemes such as Quadrature Amplitude Modulation and Quadrature Phase Shift Keying with these systems and get the best modulation schemes with less BER. Then with the combination of modulation schemes analyze the different encoding schemes such as Cyclic Redundancy Code and Reed – Solomon encoding with these systems. After that redesign the OFDM system with best encoding and modulation schemes.

**Keywords:** OFDM, BER, CRC, RS

## I. INTRODUCTION OF OFDM

OFDM is very similar to the well-known and used technique of FDM. OFDM uses the principles of FDM to allow multiple messages to be sent over a single radio channel. It is however in a much more controlled manner, allowing an improved spectral efficiency.

A simple example of FDM is the use of different frequencies for each FM radio stations. All stations transmit at the same time but do not interfere with each other because they transmit using different carrier frequencies. Additionally they are bandwidth limited and are spaced sufficiently far apart in frequency so that their transmitted signals do not overlap in the frequency domain. At the receiver, each signal is individually received by using a frequency tunable band pass filter to selectively remove all the signals except for the station of interest. This filtered signal can then be demodulated to recover the original transmitted information.

OFDM is different from FDM in several ways. In conventional broadcasting each radio station transmits on a different frequency, effectively using FDM to maintain a separation between the stations. There is however no coordination or synchronization between each of these stations. With an OFDM transmission the information signals from multiple stations is combined into a single multiplexed stream of data. This data is then transmitted using an OFDM ensemble that is made up from a dense packing of many subcarriers.

All the subcarriers within the OFDM signal are time and frequency synchronized to each other, allowing the interference between subcarriers to be carefully controlled. These multiple subcarriers overlap in the frequency domain, but do not cause Inter-Carrier Interference due to the orthogonal nature of the modulation. Typically with FDM the transmission signals need to have a large frequency guard-band between channels to prevent interference[5]. This lowers the overall spectral efficiency. However with OFDM the orthogonal packing of the subcarriers greatly reduces this guard band, improving the spectral efficiency as shown in Figure 1 below.

All wireless communication systems use a modulation scheme to map the information signal to a form that can be effectively transmitted over the communications channel. A wide range of modulation schemes has been developed, with the most suitable one, depending on whether the information signal is an analogue waveform or a digital signal.

Some of the common analogue modulation schemes include Frequency Modulation, Amplitude Modulation, Phase Modulation, Single Side Band, Vestigial Side Band, Double Side Band Suppressed Carrier. Common single carrier modulation schemes for digital communications include, Amplitude Shift Keying, Frequency Shift Keying, Phase Shift Keying and Quadrature Amplitude Modulation.

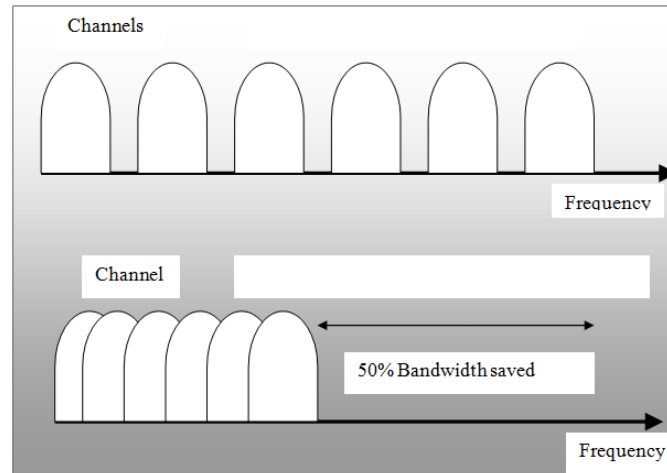

Figure 1. Concept of OFDM signal (a) Conventional Multi-carrier technique  
(b) Orthogonal Multi-carrier modulation technique.

Each of the carriers in a FDM transmission can use an analogue or digital modulation scheme. There is no synchronization between the transmission and so one station could transmit using FM and another in digital using FSK. In a single OFDM transmission all the subcarriers are synchronized to each other, restricting the transmission to digital modulation schemes. OFDM is symbol based and can be thought of as a large number of low bit rate carriers transmitting in parallel. All these carriers transmit in unison using synchronized time and frequency, forming a single block of spectrum. This is to ensure that the orthogonal nature of the structure is maintained. Since these multiple carriers form a single OFDM transmission, they are commonly referred to as ‘subcarriers’, with the term of ‘carrier’ reserved for describing the RF carrier mixing the signal from base band. There are several ways of looking at what make the subcarriers in an OFDM signal orthogonal and why this prevents interference between them.

## II. SYSTEM MODEL OF OFDM

An OFDM system has the three main parts: transmitter, channel and receiver. The basic components of an OFDM transmitter are channel coding, QPSK modulator, sub-carrier assignment i.e. OFDM baseband modulator and single carrier modulator shown in Figure 1. Since OFDM is preferably used for the uplink in a multiuser environment, low-order modulation such as QPSK with Gray mapping is preferred. However, basically high-order modulation (64-QAM) can also be employed. The sub-carrier assignment can be fixed or dynamic. In practice, in order to increase the system robustness a dynamic assignment of sub-carriers (i.e., frequency hopping) for each user is preferable. For pulse shaping, rectangular shaping is usually used which results for K users in an OFDM-type signal at the receiver side. In summary, where only one sub-carrier is assigned to a user, the modulator for the user could be a single-carrier modulator [4]. If several carriers are used for a given terminal station, the modulator will be a multi-carrier (OFDM) modulator.

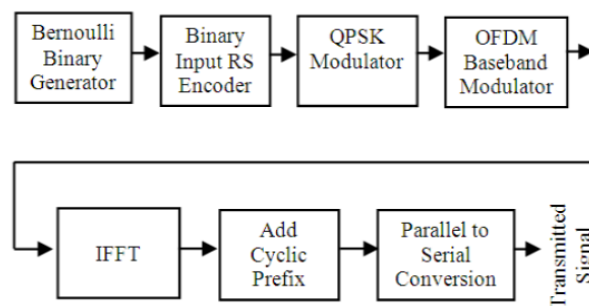

Figure 1. OFDM Transmitter.

Parallel to serial converter uses the Unbuffer block which unbuffers an  $M_i$ -by- $N$  frame-based input into a 1-by- $N$  sample-based output. That is, inputs are unbuffered row-wise so that each matrix row becomes an independent time-sample in the output. The rate at which the block receives inputs is generally less than the rate at which the block produces outputs. In the unbuffer first the data is stored at a memory location in serial form and then comes out from

other side of the unbuffer as a parallel data. The out coming data depends upon the first in first out method. Then the parallel data converted into serial form by using this unbuffer block. So simply unbuffer block acts as a temporary memory and gives output data one digit at a time to convert it serially.

At the receiver the main components are the OFDM baseband demodulator, QPSK demapping, channel decoder (with soft decisions) are used for receiving the transmitted signal and then processed this signal to get the original transmitted data. But this received signal is not same as that of the transmitted signal. The received signal is the approximation of transmitted signal by hard decision methods. For this purpose OFDM baseband demodulator and QPSK demodulation are used. For error detection and correction purpose we used channel decoder. In this model we used Reed – Solomon detector for correction of errors.

Similarly In serial to parallel converter we uses the Buffer block redistributes the input samples to a new frame size, larger or smaller than the input frame size. Buffering to a larger frame size yields an output with a slower frame rate than the input, as illustrated below for scalar input.

OFDM overcomes most of the problems with both FDMA and TDMA. OFDM divides the available bandwidth into many narrow band channels. The carriers for each channel are made orthogonal to each other, allowing them to be spaced very close together. The orthogonality of the carriers means that each carrier has an integer number of cycles over a symbol period. Due to this, the spectrum of each carrier has a null at the centre frequency of each of the other carriers in the system. This results in no interference between the carriers, allowing them to be spaced as close as theoretically possible. This overcomes the problem of overhead carrier spacing required in FDMA. Each carrier in an OFDM signal has a very narrow bandwidth (i.e. 1 kHz), thus the resulting symbol rate is low. This will give the signal a high tolerance to Multipath delay spread, because the delay spread must be very long to cause significant inter-symbol interference [5].

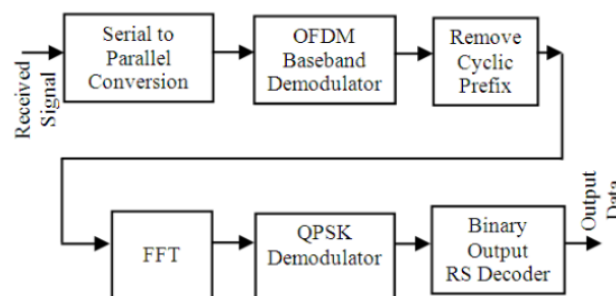

Figure 2. OFDM Receiver.

### III. OFDM PERFORMANCE ANALYSIS

First the OFDM system is analyzed with different modulation and encoding schemes. The four modulation techniques including 4 – QAM, 16 – QAM, 32 – QAM and QPSK are analyzed and the Bit Error Rate of OFDM system with these modulation schemes is calculated to check the system capacity and system robustness. Analysis was done by observing the simulation result and tabulating the analysis results to make it more convenient to be read. In the performance analysis of OFDM system the transmitted signal, received signal, scatter plots and bit error rate of the systems are analyzed.

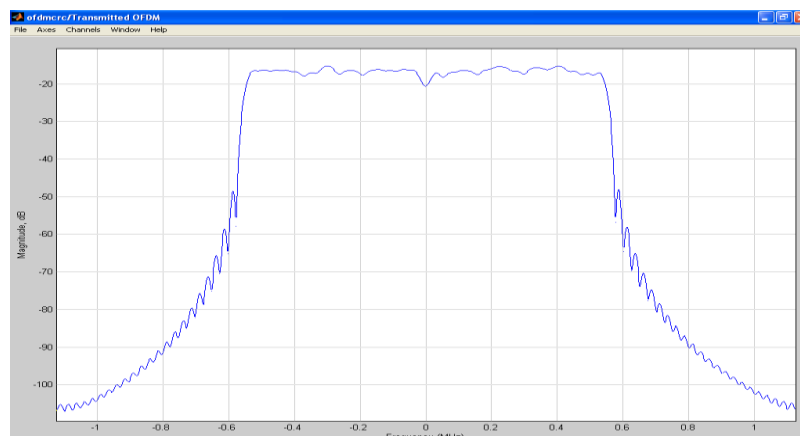

Figure 3. Transmitted Signal of OFDM System

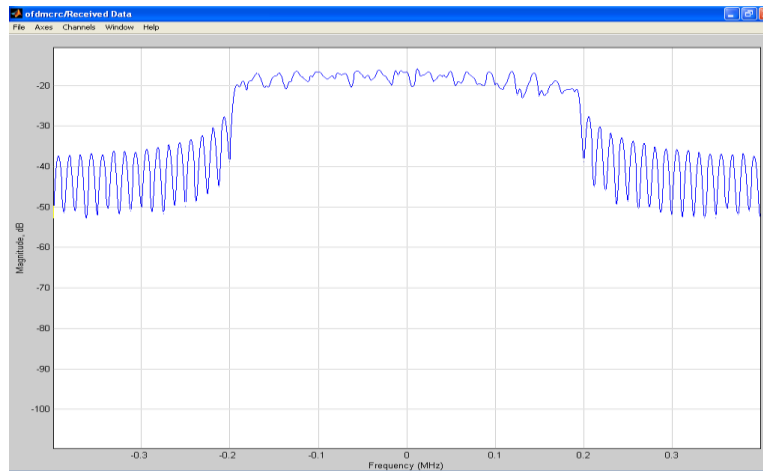

Figure 4. Received Signal of OFDM System

The Figure 3 and 4 shows the transmitted and received signal of OFDM system. To plot these signals spectrum scope is used. The Spectrum Scope block computes and displays the periodogram of the input. From the plot of transmitted and received signal it is clear that the received signal so much distorted as comparison to transmitted signal due to channel. The Scatter Plot Scope displays constellation diagram of a modulated signal, to reveal the modulation characteristics, such as pulse shaping or channel distortions of the signal. The scatter plot also shows the strength of the signal at any point in the coverage area. The constellation diagram of OFDM system with different modulation schemes are plotted by using scatter plot scopes. The Figure 5 – 8 shows the constellation diagrams of OFDM system with quadrature phase shift keying modulation, 4 – quadrature amplitude modulation, 16 – QAM and 32 – QAM respectively. It is clear that QPSK modulation is better for OFDM system as compare to QAM modulation schemes. Because in QAM modulation as the modulation index increases, the fading effect increases which is clear from Figure 5, in this figure due to large effects of distortion the constellation points are not clear or shown at some points.

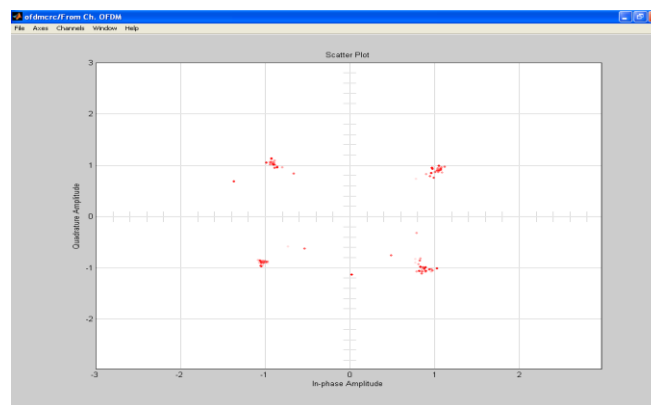

Figure 5. Constellation Diagram of OFDM System with QPSK Modulation

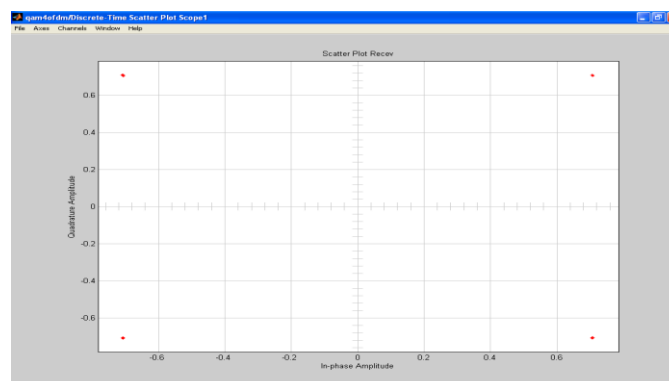

Figure 6. Constellation Diagram of OFDM System with 4 – QAM Modulation

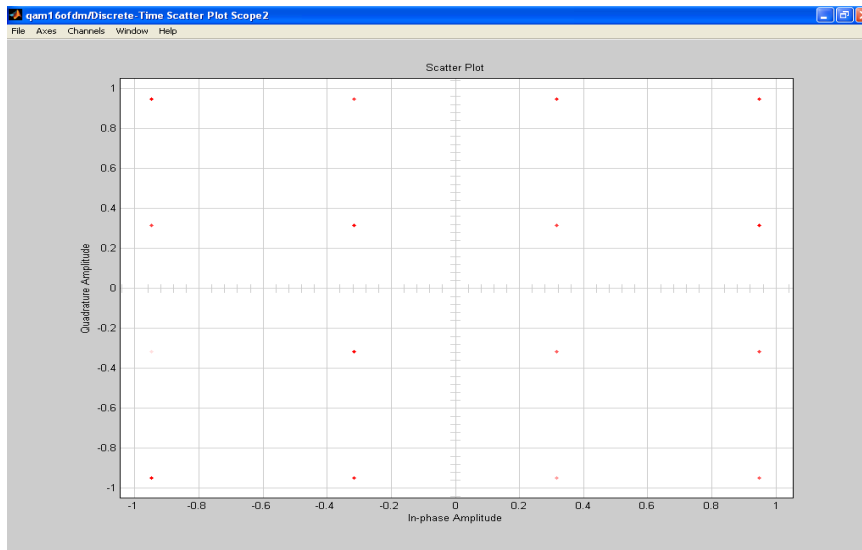

Figure 7. Constellation Diagram of OFDM System with 16 – QAM Modulation

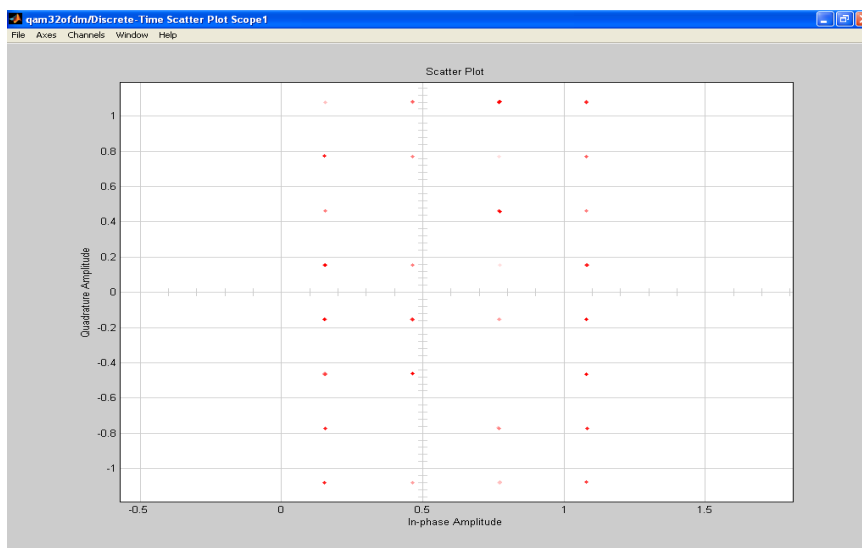

Figure 8. Constellation Diagram of OFDM System with 32 – QAM Modulation

The simulation results are plotted in term of the performance of OFDM system, that is transmitted, received signal and constellation diagrams. Now the Bit Error Rate of OFDM system is analyzed. First calculate the BER for the OFDM system with different modulation schemes such as 4 – QAM, 16 – QAM, 32 – QAM and QPSK modulation. The BER is calculated with error rate calculation block. In this block the transmitted and received signals are compared to calculate the BER. Table 1 shows the BER of OFDM with these modulation schemes.

Table 4.1. BER of OFDM with Different Modulation Schemes

Sr. No.	Modulation Scheme	Total Number of Bits	Error Bits	Bit Error rate
1.	4 – QAM	191808	143902	0.7502
2.	16 – QAM	190656	178683	0.9372
3.	32 – QAM	189888	183937	0.9686
4.	QPSK	550000	274700	0.4996

So, it is clear that QPSK modulation has less bit error rate as compare to other modulation schemes. Now by using QPSK modulation analyze the different encoding schemes for the OFDM system such as Cyclic Redundancy Code and Reed – Solomon encoding. Now compute the bit error rate by using these encoding schemes. Table 2 shown the BER of OFDM system different encoding schemes.

Table 4.2. BER of OFDM with Different Encoding Schemes

Sr. No.	Encoding Scheme	Total Number of Bits	Error Bits	Bit Error rate
1.	CRC Encoding	137500	1095	0.007964
2.	RS Encoding	137500	630	0.004582

From this table it is clear that while analyzing the different encoding schemes of OFDM system with QPSK modulation, the Reed – Solomon encoding is well suited for it. By analyzing the OFDM system with different Signal to Noise Ratio, the bit error rates are calculated. Now plot these bit error rates with respect to various signal to noise ratio. The Figure 9 shows the bit error rate plot of OFDM system with CRC encoding in respect of various signal to noise ratio. Figure 10 shows the bit error rate rate plot of OFDM system with RS encoding in respect of various signal to noise ratio. Note that the encoding schemes are analyzed with best modulation scheme i.e. QPSK modulation at various signal to noise ratio of channel.

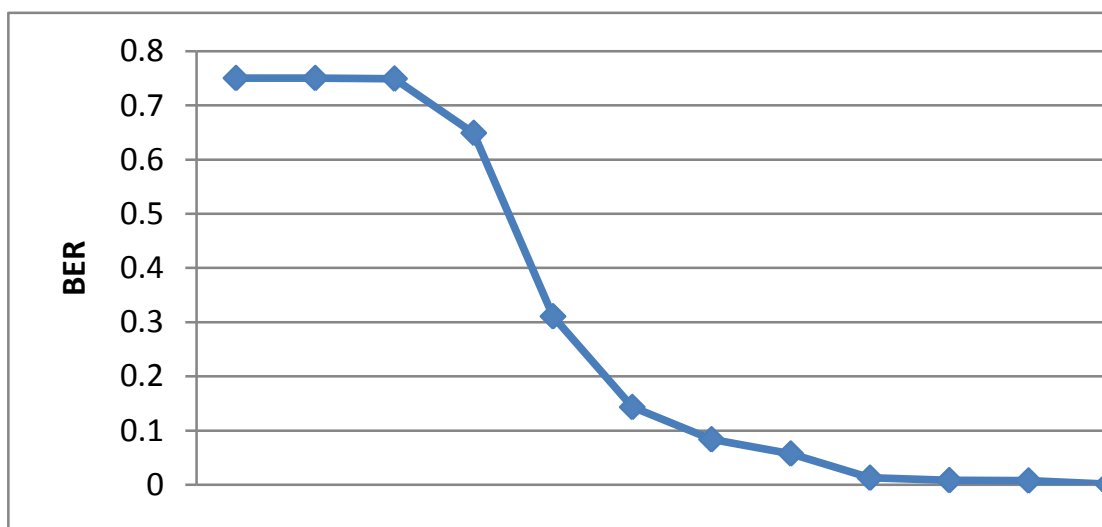

Figure 9. BER Plot of OFDM system with CRC Encoding

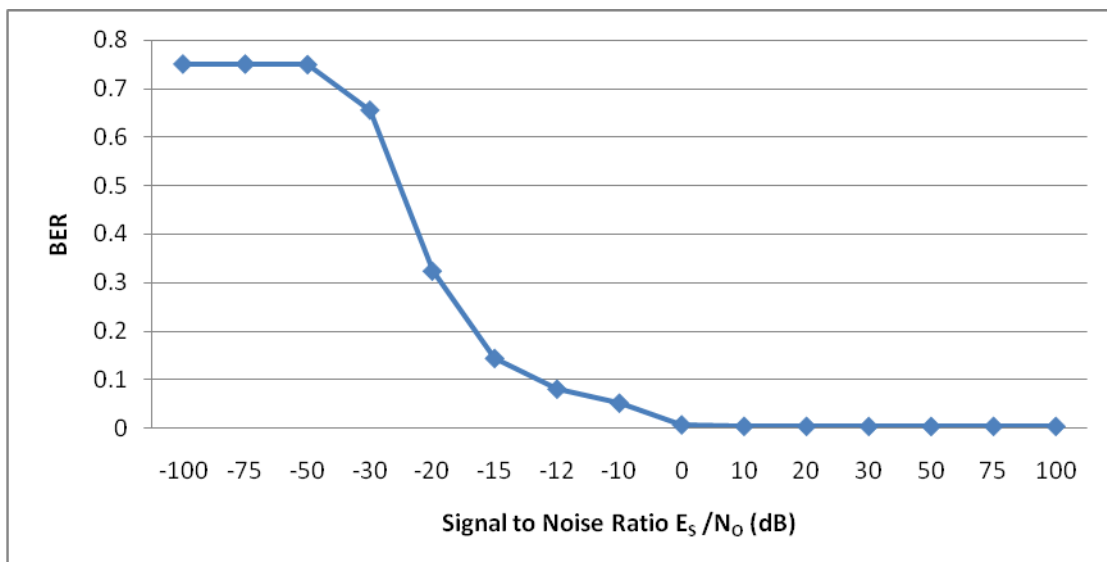

Figure 10. BER Plot of OFDM system with RS Encoding

Now from these results it is clear that from the different modulation schemes of OFDM, the QPSK modulation is best with 49.96% error without encoding scheme. Analysis of different encoding schemes of OFDM with QPSK modulation shows that Reed – Solomon encoding is well suited for OFDM system with 0.4582% error.

**IV. CONCLUSION**

There are many air interface technologies in modern mobile communication. The well known modern interface technologies is Orthogonal Frequency Division Multiplexing (OFDM) System. OFDM is a frequency – division multiplexing scheme utilized as a digital multi-carrier modulation method. A large number of closely – spaced orthogonal sub - carriers are used to carry data. OFDM system is designed to withstand with interference and fading in communication channel. Channel coding and modulation is needed for a system in order to sustain in any type of environment especially in multipath fading channel. A performance comparison of OFDM systems in Additive White Gaussian Noise and Multipath Fading channels has been presented. The comparison proceeds in two steps. First, OFDM system is analyzed for best coding (modulation and coding) schemes. A comparable bit rate is transmitted over system and different waveforms and scatter plots has been studied. On comparing the waveform of transmitted signal and received signal of both the OFDM system, it is clear that OFDM system with QPSK modulation has less distortion as compare to other modulation methods. So OFDM system can handle more number of users more efficiently. The constellation diagrams also shows that in OFDM system as the modulation index increases the fading of signal increases. In a communication system there are two main features one is efficiency of the system and other is data transmission rate of the system. OFDM has less BER i.e. 0.4582% with QPSK as modulation and Reed-Solomon as encoding scheme.

**REFERENCES**

- [1]. Anibal Luis Intini, "Orthogonal Frequency Division Multiplexing for Wireless Networks", pp.16-20, 2000.
- [2]. K. Fazel & S. keiser, "Multi Carrier and Spread Spectrum Systems" 1<sup>st</sup> ed., England: John Wiley and Sons Limited, pp. 25 – 27, 2003.
- [3]. OFDM tutorial, Covering Next Generation Computing Communication Technologies, [www.wave-report.com/tutorials/OFDM.htm](http://www.wave-report.com/tutorials/OFDM.htm)
- [4]. K. Fazel & S. keiser, "Multi Carrier and Spread Spectrum Systems" 1<sup>st</sup> ed., England: John Wiley and Sons Limited, pp. 95 – 98, 2003.
- [5]. OFDM Communications by Mohammed Agila University Ofplymouth Department of Comm. & Electronic Engineering.
- [6]. Zhiqiang Wu, Zhijin Wu, David A., Weigandt and Carl R. Nassar, "High-Performance 64-QAM OFDM via Carrier Interferometry
- [7]. Spreading Codes," IEEE Trans., pp. 557-561, 2003.
- [8]. Maninder singh, Rajiv Kumar, Vinod Kumar, Sarla Kumari and Kapil Sirohi, "Comparison of CDMA and OFDM Using Simulink", International Journal of Wireless Communication and Simulation, Volume 2, Number 1(2010), pp. 39–50.
- [9]. Maninder Singh and Prabhjot Kaur, "Performance Analysis of OFDM and UWB Systems on Basis of BER Using Simulink", International Journal of Engineering Research and Technology. ISSN 0974-3154 Volume 3, Number 3 (2010), pp. 711 – 719.
- [10]. Sandeep Sachdeva, Maninder Singh and Dr. Ajat Shatru Arora, "Reduction of Error for Load Forecasting using Fuzzy Programming and OFDM Transmission", SGI Reflections-International Journal of Science, Technology and Managment, ISSN-0976-2140, 2010.
- [11]. Jim Martin, Bo Li, Will Pressly, James Westall, "WiMAX Performance at 4.9 GHz," IEEEAC paper, Ver. 4, 2010, pp. 1-8.
- [12]. Matan Mandelbrod, "An Deadline and Minimal overhead scheduling algorithm for the wimax logical scheduler," IEEE European Wireless Conference, 2010, pp. 7-13.
- [13]. Muhammad Nadeem Khan, Sabir Ghauri, "The WiMAX 802.16e Physical Layer Model," Wireless, Mobile and Multimedia Networks IET International Conference, 2008, pp. 117-120.
- [14]. Jim Martin, Bo Li, Will Pressly, James Westall, "WiMAX Performance at 4.9 GHz," IEEEAC paper, Ver. 4, 2010, pp. 1-8.
- [15]. Muhammad Nadeem Khan, Sabir Ghauri, "The WiMAX 802.16e Physical Layer Model," Wireless, Mobile and Multimedia Networks IET International Conference, 2008, pp. 117-120.