

# Low Cost Portable Emission Tester using Bluetooth and Android Application

Supreeth.R<sup>1</sup>, Spandana.H.R<sup>2</sup>, Sneha.V<sup>3</sup>, Vineet Singh<sup>4</sup>

Student DSATM, VTU Karnataka, India<sup>1,2,3,4</sup>

**Abstract:** Emissions of many air pollutants have been shown to have a variety of negative effects on public health and the natural environment. With the ever increasing population and the need for automobiles for transportation, the number of vehicles have increased considerably which has led to increase in the emission of air pollutants such as CO, CO<sub>2</sub>, Hydrocarbons, SO<sub>2</sub>, etc., which may cause grievous problems to living beings and environment. One solution to this problem is frequent monitoring of the gases in the environment. In India, the present emission monitoring system is available only at emission testing centers located either in petrol bunks or few other places. The model we have designed can be handed over to the traffic police for continuous and instant monitoring of emission levels of vehicles. The present standard device is not portable and involves wired connections unlike our design which is portable, rechargeable and wireless. These features make our design easier to use than the traditional device. Also, our new model is comparatively cheaper than the existing device with the same level of accuracy. Unlike the present emission testing device our model uses an android application to monitor emission levels and does not require any paper work. Moreover, we express our distress in the present emission monitoring system which involves multiple malpractices by manipulating the recorded emission levels for bribe. This can be eliminated by our device which includes instant and real-time monitoring of emission levels of vehicles already certified.

**Keywords:** Emission Tester, Bluetooth, android app, COPD

## LITERATURE REVIEW

Environmental issues are caused by harmful human activities on the biophysical environment. This paper addresses one of the major environmental issues which is air pollution and steps to monitor and check the same. Environmental protection is a practice of protecting the natural environment at individual, organizational or government levels, for the benefit of the environment and all living beings. In this paper we develop a model which can monitor the emission levels of automobiles wirelessly and record the real time values. Monitoring of emission levels from time to time is vital to check and reduce air pollution caused by emission of fatal gases like CO<sub>2</sub>, CO, Methane, SO<sub>2</sub>, etc., by automobiles into the atmosphere which can cause devastating effects to the environment and living beings. Increase in carbon emissions causes green house effect and further leading to global warming. Increase in the levels of air pollutants can lead to bronchitis, asthma, emphysema or COPD (Chronic Obstructive Pulmonary Disorder) and also lung cancer. Recently due to increase in air pollution in New Delhi, India has led to the formation of thick smog leading to many fatal diseases. This forced the government in New Delhi to implement the „Odd/Even“ scheme. Regular and efficient methods of monitoring the vehicular emission levels may have prevented this condition. The present emission monitoring system is almost outdated. It is only available at emission testing centres, is not portable, expensive, involves using long wires and also requires paperwork. So we have developed a device named electronic nose which is of low cost, has almost the same accuracy, portable, wireless, instant monitoring device and can be used anywhere, anytime by individuals who intend to monitor the emission levels. It is our distress to tell you that many malpractices are taking place in the present emission testing scenario. Our model enables instant and real time monitoring and verification of emission data by the traffic police. This eliminates the manipulation of the real emission data. Since our model is equipped with Bluetooth, the data can be transmitted wirelessly to the output device unlike the existing system. Also we have developed an android application which statistically and graphically displays the accurate data of the respective vehicles and has a provision to enter the vehicle registration number as well. Any android device can be used to monitor the emission levels with the android application installed in it. The real time values and graphical data can be stored in the SD card along with the peak values of the individual gases. Our device has been calibrated according to the industry standards and can also be scaled according to the new standards. If this device is used to monitor the emission levels by traffic police on road, rigorous monitoring of emission levels can be achieved and required actions can be taken against the defaulters. This would prevent major catastrophes mentioned earlier. There is a saying “Little drops of water make the mighty ocean”. So as responsible citizens, let’s contribute and help save our mother nature.

### EXISTING EMISSION SYSTEM

The block diagram of the existing emission testing system is as shown in Figure (1).

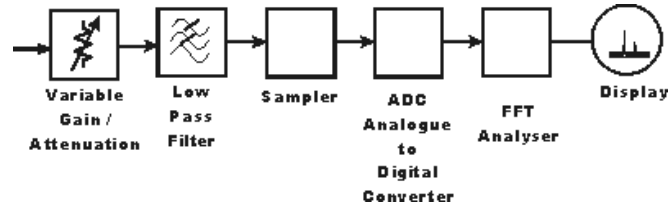

Fig 1:Block diagram of existing emission testing system

Figure (2) shows a photograph of one of the emission testing centres. As seen in the figure, the existing device is large and has wired connections between the sensing and output devices, making it a non-portable device. This is one of the major short comings in the existing system. Our device is capable of wireless monitoring, is light weight, compact and portable. These features make it possible for the traffic police to monitor emission levels instantaneously.



Fig. 2:Photograph of an emission testing centre

The below report reflects the emission readings of a particular tested vehicle on a particular date and time and is valid for 6 or 12 months and therefore the traffic police department has to accept this report without verification. But, by using our model, traffic police can monitor or verify the emission data instantaneously, thereby reducing the possible malpractices and also increasing transparency. We use an android application which displays the emission data and a soft copy can be stored in the SD card of the device, thereby eliminating the need to print result of the emission test.



Fig.3Emission report of a vehicle

III. BLOCK DIAGRAM OF ELECTRONIC NOSE

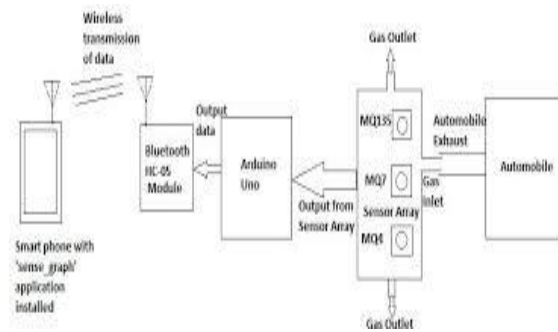

Fig .4 General block diagram of electronic nose

The block diagram of the electronic nose is as shown in figure (4). It consists of an array of three sensors- MQ-4 , MQ-135 and MQ-7 for sensing hydrocarbons (HC), Carbon-dioxide (CO<sub>2</sub>), Carbon monoxide (CO) and Alcohol(C<sub>2</sub>H<sub>6</sub>O) respectively. These sensors are arranged in an array to record the emission parameters simultaneously. Figure (5) shows MQ-4, Figure (6) shows MQ-7 figure(7) shows MQ-135, figure(8) shows MQ-3 respectively.



Figure (5) : MQ-4



Figure (6):MQ-7



Figure(7):MQ-135



Figure(8)shows MQ-3

Figure (9) shows the circuit connections of a general MQ sensor. This connection is the same for all three sensors. The sensed data is now transmitted to a microcontroller for processing. We have used Arduino UNO as the microcontroller.

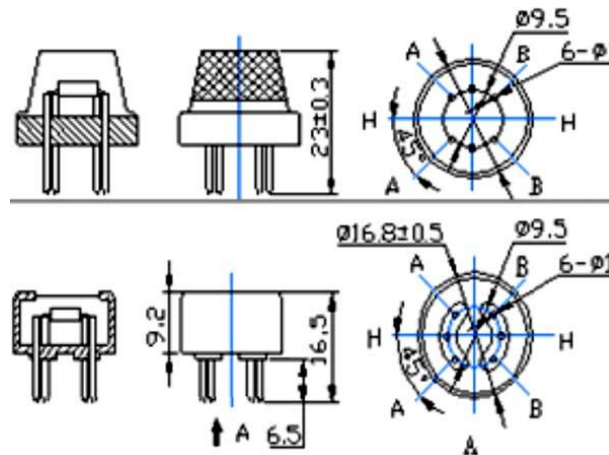

Figure (9):General circuit connections of MQ sensor.

The analog input pins are connected to the respective analog output pins of the MQ sensors. And the analog real-time data is processed by the Arduino UNO containing the ATmega328P microcontroller. The processed data is now transmitted through the Bluetooth wirelessly to the android smart phone with the application installed in it. Figure (10) shows the HC-05 Bluetooth module and figure (11) shows the android application named „PORTABLE EMISION“ developed by us for monitoring and storing the emission data.

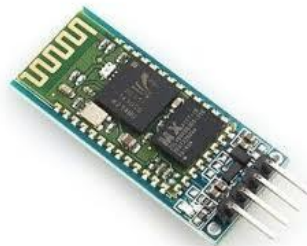

Figure (10) :HC-05 Bluetooth module

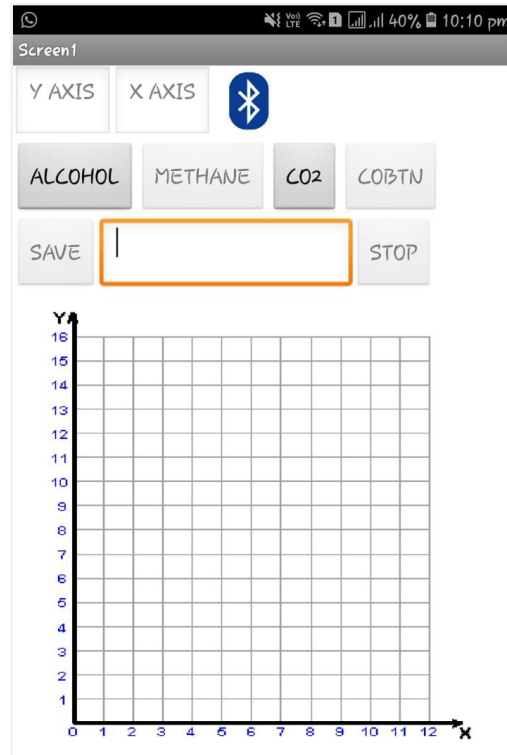
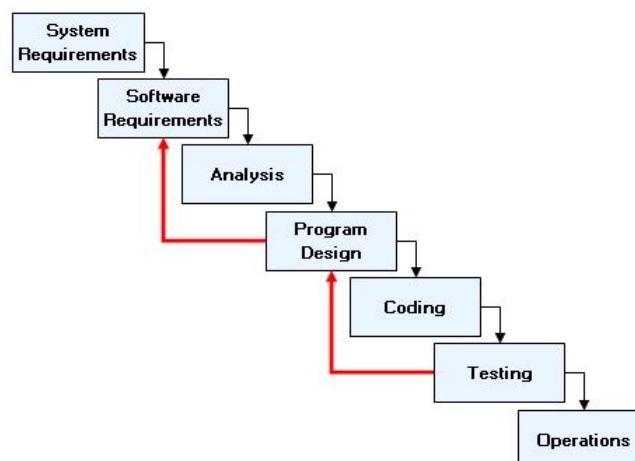

Figure (11):android application

#### IV.WORKING

##### A. Embedded System

Design to design the embedded system for our project, we have followed the iterative waterfall model of embedded system design. Figure (13) shows the flowchart of iterative waterfall model. Basically, our requirements are MQ-135, MQ-4 , MQ-7 and MQ-3 which are CO<sub>2</sub>, HC,CO and ALCHOL gas sensors respectively placed in an array called “sensor array”.



Figure(13:) Iterative waterfall model of embedded system design.

We have used Arduino UNO as the microcontroller to process the data output from the sensor breakout board. The analog output from the MQ sensor array is amplified using LM-393 and there is also provision for sensitivity adjustment. The analog output from the respective MQ sensors with breakout is given to analog ports A0, A1 and A2 of the Arduino UNO respectively.

A Bluetooth module HC-05 is used to wirelessly transfer serial data to the smart phone with android application installed in it. The range of the HC-05 Bluetooth is approximately 10 metres (30 feet). By placing the device near the exhaust of the automobile, one can monitor the emission readings on the Smartphone using our android application. A provision is given in the smart phone application to enter the registration number of the vehicle whose emission is being monitored. A graph of time v/s amplitude of the emissions (CO, CO<sub>2</sub> and HC) is plotted. CO and CO<sub>2</sub> are represented in % vol and HC is represented in ppm according to the present standards in India. Also a provision is made to display the peak values of these gases

**B. Calibration**

In India, the present measurement units for vehicular emissions are % vol for CO and CO<sub>2</sub> and ppm for HC.

So, our device was calibrated according to the present industry standards of measurements and our device faithfully matches the accuracy of that of the present device. The threshold values of these gases placed by the government is as shown in Table I and electronic nose is capable of issuing a warning in case the emission levels of a vehicle being monitored is higher than the threshold value.

S.No	Vehicle type	Present		Proposed	
		CO %	HC (ppm)	CO %	HC (ppm)
1	2 Wheelers ( 2/4 stroke) & 3 wheelers ( Pre year 2000)	4.5	-	4.5	9000
2	2 Wheelers ( 2-stroke) & 3 wheelers ( Post year 2000)	4.5	-	3.5	6000
3	2 & 3 Wheelers ( 4 stroke) ( Post year 2000)	4.5	-	3.5	4500
4	4 wheeler vehicles ( Post year 2000) ( Petrol/ CNG/LPG)	3.0	-	3.0	1500
5	Bharat Stage-II compliant Passenger cars/CNG Buses/ LPG (Fitted with 3 way closed loop catalytic converter)	3.0	-	0.5	750

TABLE 1

**CONCLUSION**

As we can see, the compact and accurate report generated by the electronic nose and displayed wirelessly using „PORTABLE EMISION“ android application. This report is saved in the SD card along with the vehicle number. Table II shows the emission results of few vehicles obtained using the electronic nose. We have designed a device named the “Electronic Nose” which is portable, low cost, wireless, rechargeable, compact and easy to use so that monitoring of emission levels of automobiles becomes easier thereby keeping a check on vehicular emissions and its grievous effects on the environment and living beings. The use of android application instead of other output devices can revolutionize the current system of monitoring the emission data.

**REFERENCES**

- [1]. Portable Low Cost Electronic Nose for Instant and Wireless Monitoring of Emission Levels of Vehicles Using Android Mobile Application,author Vishesh.S.
- [2]. CEO-KONIGTRONICS.
- [3]. The green house effect- facts on climate change- <http://climatechange.gc.ca/default.asp?lang=En&n=1A0305D5-1>
- [4]. The odd/even scheme in New Delhi to tackle air pollution - <http://timesofindia.indiatimes.com/city/delhi/Odd-even-schemerolls-out-in-Delhi/articleshow/50402441.cms>
- [5]. MQ-4 gas sensor data sheet with specifications- <https://www.sparkfun.com/datasheets/Sensors/Biometric/MQ-4.pdf>
- [6]. MQ-7 gas sensor data sheet with specifications- <https://www.sparkfun.com/datasheets/Sensors/Biometric/MQ-7.pdf>
- [7]. MQ-135 gas sensor data sheet with specifications- <https://www.olimex.com/Products/Components/Sensors/SNSMQ135/resources/SNSMQ135.pdf>
- [8]. [Arduino UNO (USA only) and Genuino UNO (outside USA) specifications- <https://www.arduino.cc/en/Main/ArduinoBoardUno>
- [9]. ATMEL 8-Bit Microcontroller with 4/8/16/32KBytes IN-SYSTEM Programmable Flash DATASHEET- [http://www.atmel.com/images/Atmel-8271-8-bit-AVRMicrocontroller-ATmega48A-48PA-88A-88PA-168A-168PA-328328P\\_datasheet\\_Complete.pdf](http://www.atmel.com/images/Atmel-8271-8-bit-AVRMicrocontroller-ATmega48A-48PA-88A-88PA-168A-168PA-328328P_datasheet_Complete.pdf)
- [10]. HC-05 Bluetooth module data sheet along with specifications <http://www.electronic60norte.com/mwfls/pdf/newBluetooth.pdf>.