



Induction Generator Based Hybrid Power Generation System for Aircraft

Amjith S¹, Ananthu Vijayakumar²

PG Scholar, Dept. of Electrical and Electronics Engineering, Sree Buddha College of engineering, Pattoor, India¹

Assistant Professor, Dept. of Electrical and Electronics Engineering, Sree Buddha College of engineering, Pattoor, India²

Abstract: Induction machines are the widely used machines in many industrial applications. Enlistment machines are generally utilized as a part of enterprises because of its ease and least upkeep. In more electric aircraft (MEA), both ac and dc electric power with different voltage levels is required for different airplane loads. This paper introduces an enlistment generator-based ac/dc crossover electric power age framework for MEA. In the proposed system design, a fast enlistment starter/generator and a low-speed acceptance generator are introduced on the high pressure (HP) and low pressure (LP) spools of the motor, separately. In creating method of activity, the bigger part of the steady voltage variable recurrence ac power is produced by the HP generator while the dc control request is shared by both HP and LP generators. A control conspire is produced to manage the ac stack voltage and organize dc control age between the two generators. The proposed induction generator based ac/dc hybrid generation system outcomes in reduced hardware requirement compared with both ac and dc primary generation systems.

Keywords: Aircraft, distributed power generation, generators, induction motors, power generation control..

I. INTRODUCTION

The developing trend toward more electric architecture for airplanes is planned to replace mechanical, hydraulic, and pneumatic systems with electrical systems as possible. It is commonly considered that the more electric aircraft (MEA) would prime to lower fuel consumption and emissions, reduced maintenance, and feasibly lower costs [1]–[4]. Improvements of on-board electrification have augmented the electric power demand of the aircraft. A substantial raise of generation capacity is essential to supply the additional loads. In contemporaneous MEA systems (e.g., Boeing 787, Airbus A380), the wound-field synchronous generator (SG)-based ac primary generation system [5], [6] can provide the frequency insensitive loads straight from the SG terminals. The constant voltage variable frequency (CVVF) ac load voltage is controlled by controlling the field current of the SG through an external brushless exciter. This exciter involves of a permanent magnet (PM) machine and a diode rectifier attached on the generator shaft. By adjusting the excitation of the field winding, the ac source voltage can be regulated with flexible shaft speed. However, in the SG-based ac primary generation system, the complex rotor structure marks the torque to inertia ratio of SG lower than other type of electric machines [1]. Moreover, the rotating diode bridge structure limits the top speed of the generator shaft. If the synchronous permanent magnet machine is used as a starter/generator, separate field and armature voltage controls are necessary during its motoring operation.

In MEA systems, the effect of electrical power off take can occasionally have significant impact on the dynamics and control of the aircraft engine [7]. For instance, through the transition from cruise to descent phase, the aircraft engine power is transiently reduced while maintaining high electrical power request. This transition creates a possibility of engine instability and may require significant electric load shedding. This issue can be resolved by installing an extra generator on the low pressure (LP) spool of the engine and distribution the electrical power withdrawal between the high pressure (HP) and LP spools [4]–[7]. In order to parallel the two generators operated at dissimilar frequencies, a dc primary generation system with power electronic converters is favoured as an innovative more electric architecture [8], [9]. PM generator is favoured in this twin spool twin-generator architecture owing to its high-power density and self-excited ability [8]–[10]. A high-speed starter/generator and a low-speed generator are positioned directly on the HP and LP spool of the engine, individually. In the engine starting development, the PM starter/generator on HP spool can run as a motor to start the engine using ground power supply. During the flight mission, the power generated from the two generators are rectified and transferred to a ± 270 -V dc power bus. This category of system presents high power factor and high efficiency, but undergoes from excessive current flow during fault condition because of the use of PM



generators [10]. While multiphase fault-tolerant PM generators have been inspected to limit the short-circuit fault current [11]–[13], using PM generator to fulfil the overload current necessity of main engine generator in aerospace application is still challenging. Furthermore, mounting the PM generator near to the gas turbine engine may seriously affect the system reliability since most PM materials are weak to demagnetization under very high temperature. Finally, compared to the SG based ac primary generation system design, the CVVF power demanded by frequency insensitive loads (e.g., thermal mat, wing de-icing system, galleys, etc.) in dc primary generation system is first converted to dc power by the active rectifier of the generator, and inverted back to ac power through dedicated inverters. This two-stage ac–dc–ac conversion enhances extra losses and further hardware to the system. In Boeing 787, under cursing condition, the power spent by the frequency insensitive ac loads is near to 50% of the overall electrical power consumption [8]. Using induction machine as main engine generator in aircraft application is rarely reported in literature [14]–[16]. In medium power applications (50–150 kW), the power density of induction generator (IG) is comparatively higher than wound-field SG, but lower than PM generator [17]. Nonetheless, the concern of excessive fault current owing to the PM excitation for airborne applications can be simply addressed by using IGs. In addition, the internal impedance of IG is the lowest among all type of generators. From the generation system architecture point of view, since neither ac nor dc primary generation system is able to meet all the power requirements with optimized performance in terms of volume, weight, efficiency, reliability, and cost. Hence, in this paper, an IG-based ac/dc hybrid generation system is proposed to combine the advantages and address the shortcomings of both systems. In this paper, the configuration of the proposed induction generator based ac/dc hybrid generation system for MEA is presented. A steady-state analysis is carried out to clarify the proposed twin-spool twin-generator ac/dc hybrid generation technique.

II. BLOCK DIAGRAM DESCRIPTION

In the proposed system, as shown in fig. 1, a high-speed open-end winding squirrel-cage induction starter/generator and a low speed conventional wye-connected squirrel-cage IG are attached to the HP and LP spools of the engine, correspondingly.

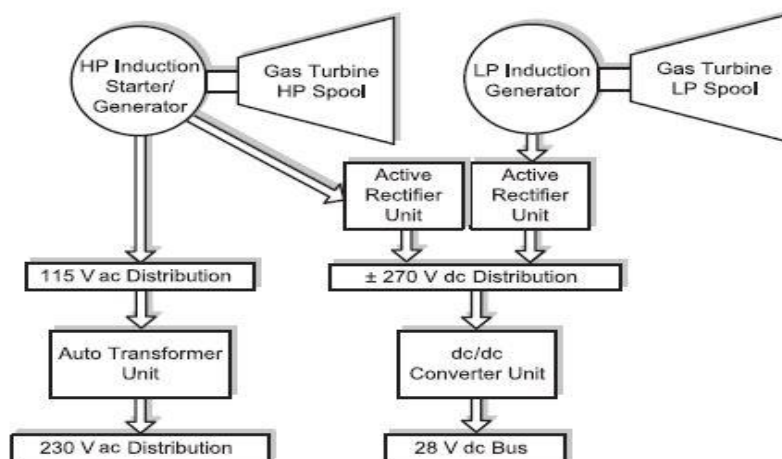

Fig.1. Block diagram of proposed system

In generating mode of operation, the HP generator is in charge of generating all of the CVVF power, though the dc power demand is shared by both HP and LP generators. The proposed ac/dc hybrid generation architecture can supply CVVF power directly from one end of the generator winding terminals without external exciter, and generate dc power on the other side of the generator winding terminals through an inverter/rectifier part. From the generation system style approach, compared to dc primary generation system, the undesired ac–dc–ac conversion is avoided by applying ac/dc hybrid generation on HP spool in the proposed scheme, while the merits of the twin-spool twin-generator dc primary generation architecture have been kept. As associated to the ac primary generation system, the application of IG eliminates the external exciter, while the twin-spool twin-generator architecture improves the overall generation performance. As a result, the overall hardware requirement of the proposed system is reduced compared to both ac and dc primary generation structures. An inverter/rectifier unit and frequency insensitive ac loads are coupled to each end of the HP spool open-end winding IG terminals. An active rectifier unit is connected to the LP spool wye-connected IG. The dc output end of the inverter/rectifier unit and the active rectifier unit are paralleled to the dc bus. In most of the



MEA applications, also generating electric power, the main engine generator is used as a starter for aircraft engine. A dc power supply from the APU generation system or ground power supply is generally available for this process. In the engine starting type of operation, the entire LP spool generation subsystem is deactivated. The ac loads are disconnected from the HP generator, and the ac load-side generator terminals are shorted to transform the open-end IG on HP spool into a wye-connected induction motor. Additional circuit breakers are necessary to implement this transformation. Using the dc power supply, the converted induction motor can be driven by the inverter/rectifier unit to start the aircraft engine. Once the engine shaft touches its idle speed, the proposed system initiates to operate in generator mode. In this mode of action, the ac load-side terminals of the HP generator are linked to the CVVF loads and the wye connected IG on LP spool is activated. All the CVVF power is generated only by the HP generator, although the power demand of the dc loads is shared between both the HP and LP generators. The dc-bus capacitor will be fully charged at the start of the generator mode of operation. In the proposed ac/dc hybrid generation system, as a substitute of using a conventional wye-connected IG and connecting the CVVF loads in parallel with the inverter/rectifier unit [19], the CVVF loads, and the HP shaft open-end winding IG, and the inverter/rectifier unit are connected in series. Compared to the conventional shunt connected configuration [19], the series connected inverter/rectifier unit needs higher current ratings. But, the open-end winding generator configuration can increase the output voltage of the generator [20], [21], from which the current rating of the generator can be reduced for the same amount of power generation demand. As a result, the size and weight of the generator can be greatly reduced compared to the shunt connected configuration.

III. MODELLING OF INDUCTION MACHINE

Mathematical modelling equations of induction machine is given below, Stator and rotor voltage equations are,

$$V_{qs} = R_s i_{qs} + \frac{d\phi_{qs}}{dt} + \omega_e \phi_{ds} \quad (1)$$

$$V_{ds} = R_s i_{ds} + \frac{d\phi_{ds}}{dt} + \omega_e \phi_{qs} \quad (2)$$

$$V_{qr} = R_r i_{qr} + \frac{d\phi_{qr}}{dt} + \omega_e \phi_{dr} \quad (3)$$

$$V_{ds} = R_s i_{ds} + \frac{1}{\omega_b} \frac{d}{dt} F_{ds} - \frac{\omega_e}{\omega_b} F_{qs} \quad (4)$$

$$V_{qs} = R_s i_{qs} + \frac{1}{\omega_b} \frac{d}{dt} F_{qs} + \frac{\omega_e}{\omega_b} F_{ds} \quad (5)$$

$$V_{dr} = R_r i_{dr} + \frac{1}{\omega_b} \frac{d}{dt} F_{qr} + \frac{(\omega_e - \omega_r)}{\omega_r} F_{dr} \quad (6)$$

$$V_{qr} = R_r i_{qr} + \frac{1}{\omega_b} \frac{d}{dt} F_{dr} - \frac{(\omega_e - \omega_r)}{\omega_r} F_{qr} \quad (7)$$

Where V_{ds} , V_{qs} , V_{dr} and V_{qr} are the stator and rotor d axis voltages and q axis voltages respectively. R_s and R_r are stator and rotor resistance, ω_e is the angular speed and ω_r is the rotor speed. i_{ds} , i_{qs} , i_{dr} , and i_{qr} are the stator and rotor d axis currents and q axis currents respectively. F_{ds} , F_{qs} , F_{dr} and F_{qr} are the flux linkages. Flux linkage expressions are,

$$\frac{d}{dt} F_{qs} = \omega_b [V_{qs} - \frac{\omega_e}{\omega_r} F_{ds} + \frac{R_s}{X_{ls}} (F_{mq} - F_{qr})] \quad (8)$$

$$\frac{d}{dt} F_{ds} = \omega_b [V_{ds} - \frac{\omega_e}{\omega_r} F_{qs} + \frac{R_s}{X_{ls}} (F_{md} - F_{ds})] \quad (9)$$

$$\frac{d}{dt} F_{dr} = \omega_b [V_{qr} - \frac{\omega_e - \omega_r}{\omega_r} F_{dr} + \frac{R_r}{X_{lr}} (F_{mq} - F_{qr})] \quad (10)$$

$$\frac{d}{dt} F_{qr} = \omega_b [V_{dr} - \frac{\omega_e - \omega_r}{\omega_r} F_{qr} + \frac{R_r}{X_{lr}} (F_{md} - F_{dr})] \quad (11)$$

Where F_{md} and F_{mq} are the mutual flux linkages of d axis and q axis respectively. MATLAB model of induction machine is shown in fig 2.

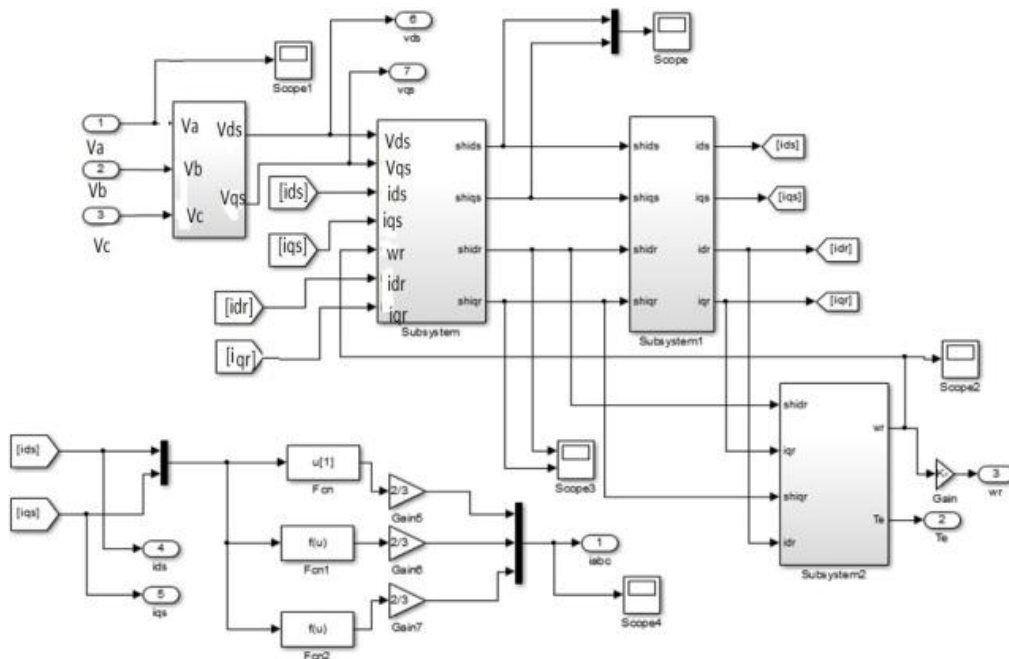

Fig. 2. MATLAB model of induction machine

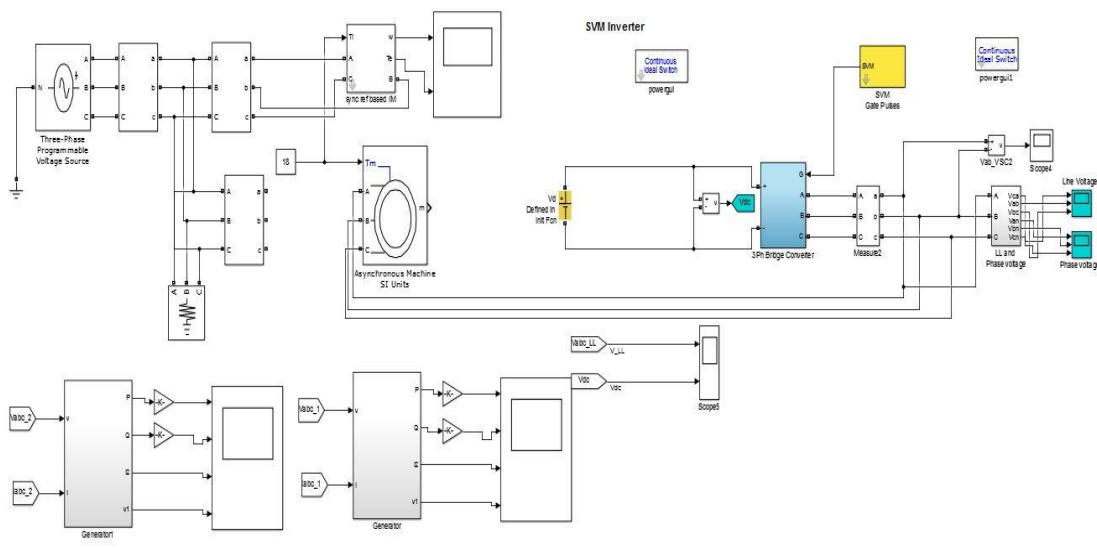

Fig. 3. MATLAB model of proposed system

It is also mentioned as hill climbing or P & O method, since it depends on the growth of power against voltage which is under the maximum power point, and the drop above that particular point. Perturb and observe method probably will result in top-level efficiency. Fig 3 represents the proposed system model of IG based hybrid power generating system for aircraft.



TABLE I GENERATOR 1 PARAMETERS

TABLE I

Parameter	Value	Parameter	Value
Output voltage	115 V	Stator resistance, R_s	0.01373 Ω
Stator current	492 A	Stator inductance, L_s	0.0499 H
Rated speed	11060 rpm	Magnetizing inductance	2.9 mH
Frequency	368 Hz	Nominal power	85 kW

GENERATOR 2 PARAMETERS

Parameter	Value	Parameter	Value
Output voltage	115 V	Stator resistance, R_s	1.405 Ω
Stator current	350 A	Stator inductance, L_s	0.0058 H
Rated speed	3150 rpm	Magnetizing inductance	3 mH
Frequency	105 Hz	Nominal power	60 kW

IV. MATLAB/SIMULINK RESULTS AND DISCUSSIONS

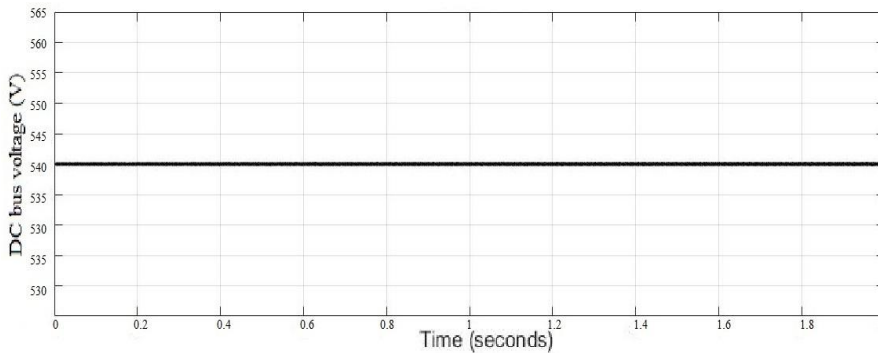

Fig. 4. DC bus voltage regulation characteristics of the proposed system

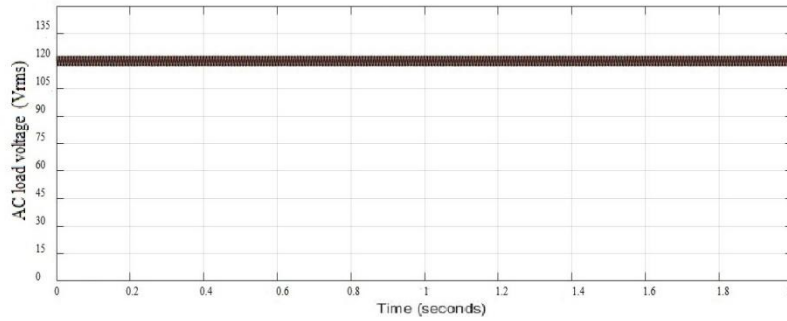

Fig. 5. AC load voltage regulation characteristics

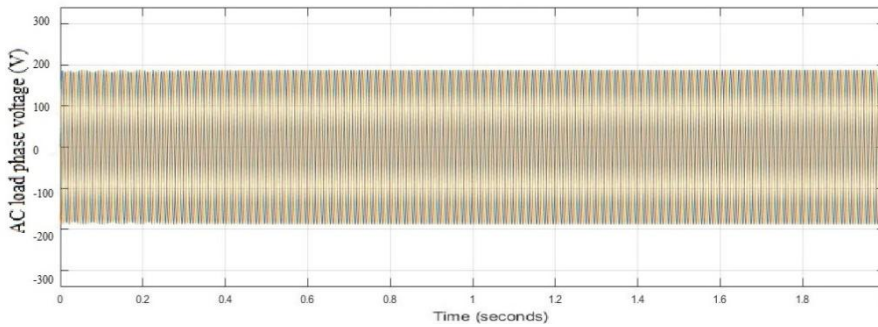

Fig. 6. AC load phase voltages

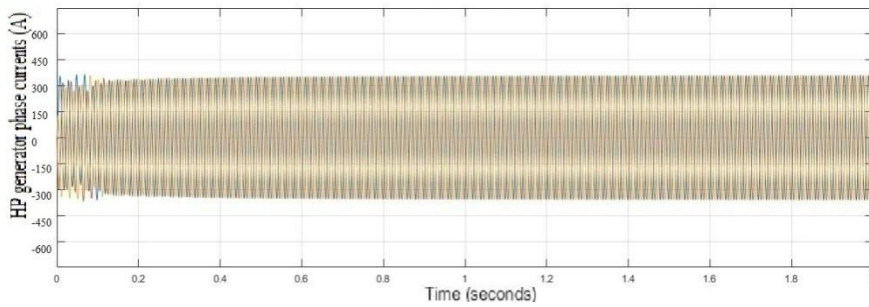

Fig. 7. Phase current characteristics of the HP generator

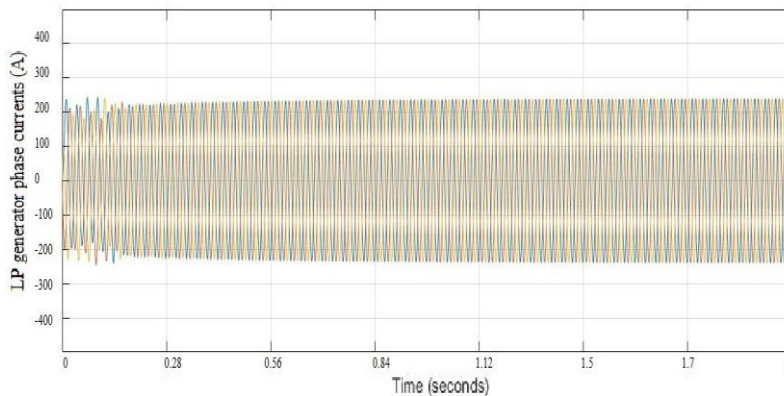

Fig. 8. Phase current characteristics of the LP generator

Based on the complete non-linear dynamical mathematical model, numerical simulations have been conducted after successive step changes on the load coupled to the induction machine. A 85 kW, 11060 r/min IG and a 60 kW, 3150 r/min IG are used on HP and LP spools, respectively. The proposed architecture includes HP generator, the inverter/rectifier unit, and 115 V balanced resistive ac load; as well as the LP generator, the active rectifier unit, and



540 V dc loads on the main dc bus. Currently, airborne electrical power system does not have an official voltage regulation standard for 540-V dc bus. The closest available standard (MIL-STD-704F) is for 270-V dc bus and limits the voltage variation so as not to exceed $+10\% - 20\%$ in steady state. Assuming the voltage variation limitation in MIL-STD-704F is doubled for the 540-V dc bus, the voltage variation allowed for the dc voltage regulation for the proposed system would be $+20\% - 40\%$. The transient voltage limitation of the proposed system is assumed to be doubled for the same reason. The dc-bus voltage waveform is shown in Fig. 4, the assumed voltage limit of the 540-V dc bus is illustrated as red lines. The ac load voltage waveform of the planned system is shown in Fig. 5, the steady-state and transient voltage limit for a variable frequency 115-V ac distribution in MIL-STD-704F. The ac load phase voltages are shown in fig. 6. The current waveforms of the HP and LP generators in the proposed system are shown in Figs. 7 and 8.

V. CONCLUSION

The proposed Hybrid System along with the 3 Phase Induction Machine is modeled using MATLAB/SIMULINK.. An IG-based ac/dc hybrid generation system for MEA is presented. The application of IG addresses the difficult of excessive fault current due to the PM excitation in PM generator-based generation system. The proposed ac/dc hybrid generation design supplies CVVF power directly from generator terminals without external exciter. As a result, the hardware requirement is reduced compared to both dc and ac primary generation systems. Both dc and ac output voltages of the system can be well regulated with generator speed, ac and dc side load, and dc power output command variation.

REFERENCES

- [1] H. AbuRub, M. Malineowski, and K. Al-Haaddad, *Power Electronics for Renewable Energy Systems, Transportation and Industrial Applications*, Hoboken, NJ, USA: Wiley, 2014.
- [2] L. Faleireo, "Summary of the European power optimized aircraft (POA) project," in *Proc. 25th Int. Congr. Aeronautical Sci.*, 2006, pp. 1–7.
- [3] B. Bhangu and K. Rajashekara, "Electric starter generators: Their integration into gas turbine engines," *IEEE Ind. Appl. Mag.*, vol. 3, no. 2, pp. 14–22, Mar./Apr. 2014.
- [4] K. Muehlbauer and D. Gerlingg, "Two-generator-concepts for electric power generation in more electric aircraft engine," in *Proc. 19 Int. Conf. Elect. Mach.*, 2010, pp. 1–7.
- [5] W. U. Ferenando, M. Barnees, and O. Maarjanovic, "Direct drive permanent magnet generator fed AC-DC active rectification and control for more-electric aircraft engines," *IET Elect. Power Appl.*, vol. 25, no. 11, pp. 10–37, Jan. 2011.
- [6] C. R. Averye, S. G. Bulrow, and P. H. Meelleor, "Electrical generation and distribution for the more electric aircraft," in *Proc. 2007 42nd Int. Univ. Power Eng. Conf.*, Sep. 5–6, 2007, pp. 1007–1013.
- [7] M. J. Provoest, "The more electric aero-engine: A general overview from an engine manufacturer," in *Proc. 2002. Int. Conf. Power Electron., Mach Drives (Conf. Publ. No. 487)*, 2002, pp. 246–261.
- [8] G. A. Whyeatt and L. A. Chick, "Electrical generation for more-electric aircraft using solid oxide fuel cells," U.S. Department of Energy, Washington, DC, USA, Contract DE-AC05-76RL01831, 2012.
- [9] M. J. Cullen, "Permanent magnet generator options for the more electric aircraft," in *Proc. Int. Conf. Power Electron., Mach Drives (Conf. Publ. No. 487)*, 2002, pp. 241–246.
- [10] W. Jiabin, K. Atallah, and D. Howe, "Optimal torque control of fault tolerant permanent magnet brushless machines," *IEEE Trans. Magn.*, vol. 39, no. 5, pp. 2962–2965, Sep. 2003.
- [11] G. Jacek, B. C. Mecroow, and J. A. Haylock, "A comparative study of permanent magnet and switched reluctance motors for high-performance fault-tolerant applications," *IEEE Trans. Ind. Appl.*, vol. 33, no. 4, pp. 889–895, Jul./Aug. 1996.
- [12] C. Mecrowe, A. G. Jacks, J. A. Haylock, and J. Coles, "Fault-tolerant permanent magnet machine drives," *Inst. Electr. Eng. Proc-Elect. Power Appl.*, vol. 153, pp. 437–443, 1996.
- [13] C. Mecrow et al., "Design and testing of a four phase fault-tolerant permanent-magnet machine for an engine fuel pump," *IEEE Trans. Energy Convers.*, vol. 29, no. 6, pp. 671–679, Dec. 2004.
- [14] F. Khatounian, E. Monmassoen, F. Berthereau, E. Delaleau, and J. P. Louis, "Control of a doubly fed induction generator for aircraft application," in *Proc. 29th Annu. Conf. IEEE Ind. Electron. Soc.*, Nov. 2–7, 2003, vol. 3, pp. 2711–2716.
- [15] I. Alan and T. A. Lipoe, "Starter/generator employing resonant-converter fed induction machine. I. Analysis," *IEEE Trans. Aerosp. Electron. Syst.*, vol. 36, no. 5, pp. 1309–1338, Oct. 2000.
- [16] Y. Jia, U. R. Prasanna, and K. Rajashekara, "An open-end winding induction generation system for frequency insensitive AC loads in more electric aircraft," in *Proc. 40th Annu. Conf. IEEE Ind. Electron. Soc.*, Oct. 29–Nov. 1, 2014, pp. 410–419.
- [17] D. W. Novotny and T. A. Lipo, *Vector Control and Dynamics of AC Drives*, Oxford, U.K.: Oxford Univ. Press, 1996.
- [18] Y. Jia and K. Rajashekara, "An induction generator based AC/DC hybrid electric power generation system for more electric aircraft," in *Proc. 2015 IEEE Ind. Appl. Soc. Annu. Meeting*, Addison, TX, USA, 2015, pp. 1–8.
- [19] R. C. Bansale, "Three-phase self-excited induction generators: an overview," *IEEE Trans. Energy Convers.*, vol. 21, no. 3, pp. 293–299, Jun. 2005.
- [20] H. Stemmler and P. Gugenbach, "Configurations of high-power voltage source inverter drives," in *Proc. 1993 5th Eur. Conf. Power Electron. Appl.*, Brighton, U.K., 1993, vol. 5, pp. 7–15.
- [21] T. Kawabata, E. C. Ejiogeu, Y. Kawabata, and K. Nishiyama, "New open winding configurations for high-power inverters," in *Proc. IEEE Int. Symp. Ind. Electron.*, Guimaraes, Portugal, 1997, vol. 3, pp. 457–464.