



Three Way System Hybrid Vehicles Solar, Lithium-Ion Battery and Dynamo Mechanism

Deepika Lavanya N¹, Pooja Shree C.P², Raveena Elizabeth³, Vandana G⁴

Student, Dept of Electrical and Electronics Engg, Sri Venkateshwara College of Engineering, Bengaluru, India ^{1,2,3,4}

Abstract: To meet the modern day requirements of never ending fuel demand of vehicles. In present trend the scenario is mainly based on IC engines, which makes use of the crude oils. It is agreeable that it is lighter, compact and the ignition time is less and more convenient. But the main criterion which leads to the limiting the usage of such engines is the depletion of fossil fuels in present trend and in a motto of futuristic thought. This leads to the alternative thought of using three way system hybrid vehicles. This paper mainly focuses on the implementation of an ideology to minimize IC engines utility and enhance the usage of renewable sources along with the dynamo mechanism to generate back up power and usage of lithium-ion battery for more and better enhancement in back up power utility. As it is comparatively environmentally safe and can be a better choice in the future generation.

Keywords: IC engine, lithium-ion battery, dynamo mechanism, renewable resources.

I. INTRODUCTION

In this fast and speedy world, the growth what the countries are achieved and some yet to achieve the main criteria to satisfy is to meet the required power demand. In such a critical time when all the resources are about to exhaust over a course of time, raise in the temperature due to global warming and so many other issues. These parameters lead the researchers to mainly focus on renewable resources.

Many researchers and development took place in the field of electricity. But one of the major concerns is with the consumption of fuel i.e., fossil fuel and the gas produced. Due to combustion is CO₂ which is again harmful to human as well as environment. These many concerns or parameters made the researchers to the invention of hybrid electric vehicles (HEV).

HEV are the type of vehicles which along with the usage of the engine, makes use of electric motors and batteries as backups. This can be seen in fig1.

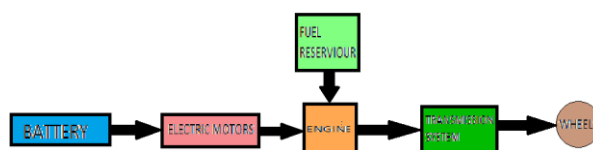

Fig.1 block diagram of HEV

According to law of conservation of energy, energy can neither be created nor be destroyed, but can be converted from one form to another. Hence in this presentation mainly focuses on the maximum usage of the energy created by the usage of PV cells, Li-ion batteries and a dynamo as a backup source.

II. LITERATURE SURVEY

After the world changing invention of electric motors by Michael Faraday in 1821 along with the invention of commutator type DC electric motor capable of turning machine, by British scientist William Sturgeon in 1832. Since then many revolutionary ideas began to evolve.[3]

One of such innovative idea was of electric locomotive which was built for the first time in 1837 by chemist Robert Davidson. His idea was powered by non-rechargeable batteries. In 1895 for the first time an electric locomotive was run on the lane, i.e., of the Baltimore Belt line in the USA. This was of 6.4km stretch.[3]

All these developments took before the invention of battery. By the end of 19th century large production of re-chargeable batteries triggered the implementation and usage of HEV.



But once the cheap oil was made widely available along with the invention of IC engines, people started to choose IC engine vehicle over the electric vehicle. This comparison could be tabulated as shown in table 1.

TABLE 1 Comparison of IC engine and Electric Vehicle

Specifications	IC engine	Electric vehicle
Specific energy	9000WhKg ⁻¹	30WhKg ⁻¹
Efficiency	20	90
Useful energy	1800Whkg ⁻¹	27Whkg ⁻¹

This even depends on the size and weight of the battery used and the overall size of the vehicle of the installation. This can be easily understood by the help of fig2.

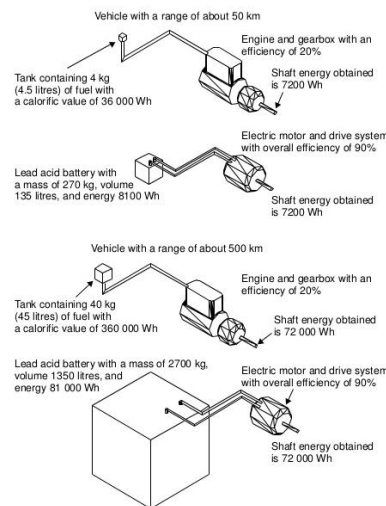

Fig. 2 advantage of using IC engine over electric vehicle [3]

The concept of hybrid vehicles arose while searching for the drawback of the electric vehicle over IC engine. Hybrid vehicle is due to use of renewable sources along with the usage of IC engine.

In 1990 ferdiandprosche developed first ever hybrid electric vehicle. By this time only trains could achieve a great success due to the less maintenance required for it. Towards the end of 20th century and the beginning of 21st century japan was the country to achieve tremendous change in this field. These fist implemented in the form bullet trains. [3]

The biggest change in the field of HEV is with the invention of the lithium ion battery.

This paper intends to learn from the drawbacks and to implement a vehicle which is eco friendly, cheap and which uses renewable resources the most. Hence a notable observation to be done that why people started to prefer IC engines over electric vehicles.[3] An easy way to comply with the conference paper formatting requirements is to use this document as a template and simply type your text into it.

III.BASIC PRINCIPLE

Basic principle is the way that any device or an invention works. Since we are making use of three different devices, individual principle is as given in the further part.

A. Solar cells (PV cells)

Photovoltaic modules, commonly called solar modules are the key components used to convert sunlight into electricity. Solar modules are made of semiconductors that are very similar to those used to create integrated circuits for electronic equipment. The most common type of semiconductor currently in use is made of silicon crystal. Silicon crystal is laminated into n-type and p-type layers. Stacked on top of each other, light striking the crystals induces the “photovoltaic effect” which is the cause of the generation of electricity. The electricity produced is in the dc (direct current) form hence it’s easy to be stored in the batteries.

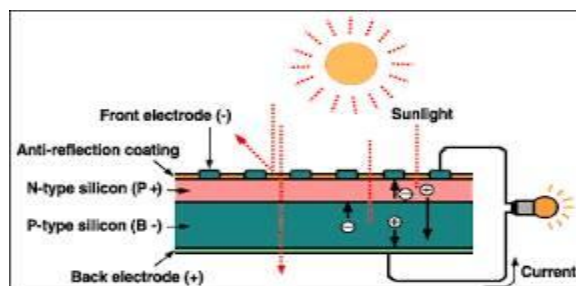

Fig. 3 cross section of PV cell. [11]

Highly pure silicon crystals are used to manufacture solar cells. The crystals are processed into solar cells using the melt and cast method. The cube shaped casting is then cut into ingots, and then silicated into ingots, and then sliced into very thin wafers. A pn junction is formed by placing p-type and n-type semiconductor next to one another. The p-type which consists of fewerelectrons attracts the surplus electron from the n-type to stabilize itself. Thus the displacement of electrons produces electricity.

When sun hits the semiconductor and electron springs up and it attracted toward the n-type semiconductor. This causes more negatives in the n-type semiconductors and more positives in the p-type, thus generating a higher flow of electricity. This is the photovoltaic effect. [14]

B. Lithium ion batteries

Two or more electrochemical cells, electrically interconnected, each of which contains two electrodes and an electrolyte. Li ion batteries are secondary batteries. Secondary batteries are one which can be recharged. The battery consists of an anode of Li, dissolved as ion into a carbon. The cathode material is made up from Li liberating compounds, typically the 3 electro active oxide materials.

- Li- cobalt oxide(LiCO_2)
- Li-manganese oxide(LiMn_2O_4)
- Li-nickel oxide(LiNiO_2)

The traditional batteries are based on galvanic action but Li-ion is secondary batteries which depend on an "intercalation" mechanism. This involves the insertion of lithium ions into the crystalline lattice of the host electrode without changing its crystal structure.

These electrodes have two key properties. One is the open crystal structure, which allow the insertion or extraction of Li-ions and the second is the ability to accept compensating electrons at the same time. Such electrodes are called intercalation hosts.

Chemical reaction is as given below

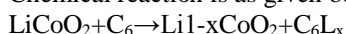

Lithium ion is inserted and exerted into the lattice structure of anode and cathode during charging and discharging. During discharging current flows through external circuit and light glows. During charging no electrons flows in the opposite directions, in this case Li in positive electrode material is ionized and moves from layer to layer and inserted into the negative electrodes. [15]

C. Dynamos

Dynamo in other way is called as electric generator. Generator is one which produces dc with the use of commutator. The dynamo uses rotating coils of wire and magnetic fields to convert mechanical rotation into a pulsing direct electric current through faraday's law of induction. A dynamo machine consists of a stationary structure, called the stator, which provides a constant magnetic fields and a set of rotating windings called the armature which turn within that field. The motion of the wire within the magnetic field causes the field push on the electrons in the metal, creating an electric current in the wire.

Requirement of commutator is when we require dc. When the loop of wire rotates in a magnetic field, the potential induced in it reverses with each half turn, generating an alternating current.

These individual components and utilisation of all of them together is the main theme of this paper. [8]

IV. OVERALL BLOCK DIAGRAM

In this section the overall design of our hybrid vehicle has been describe in the format of block diagram.

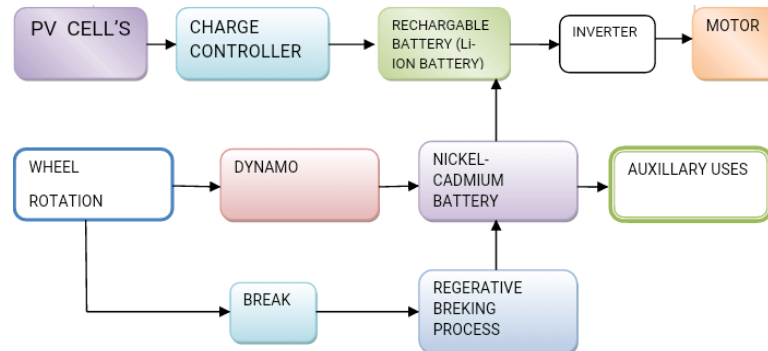

Fig.4 overall block diagram of three way HEV

In this the main component is PV cell. PV cell is a component which makes use of the sunlight in order to generate electricity. The reason for this use is mainly that it's a renewable energy source and can be obtained as long as possible. But the main drawback is that it's not a continuous process. That means that under unfair conditions or in the night time it's not able to generate electricity. Hence an alternate should be ready if it's for a long distance or so.

When the sun rays fall on the PV cell due to the photons the electrons or holes get displaced, that is the motion of charges depending on the type of the materials used to dope. This displacement of electrons causes the electricity. This current mainly depends on the temperature. As temperature varies current varies. This is as given in the equation.

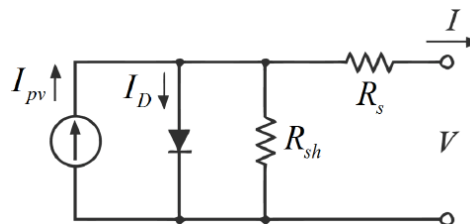

Fig.5 equivalent circuit of PV cell. [12]

$$I = I_{ph} - I_s \left(\exp\left(\frac{q(V + R_s I)}{NKT}\right) - 1 \right) - \frac{V + R_s I}{R_{sh}} \quad [10]$$

Where I = output current in amps

I_{ph} = photo current due to incident of light and is a function of temperature.

q = charge in coulombs; 1.6×10^{-19}

K = Boltzmann constant; 1.38×10^{-23}

V = cell output voltage

R_s = series resistance in ohms

R_{sh} = shunt resistance in ohms

T = temperature in kelvins

The output of this PV cell is in dc form. Hence it can be stored and can be used when required.

The charging is controlled using charge controller and its output is given to the lithium ion battery. Hence the selection of type of lithium ion battery becomes the main criteria.



Fig.6 Subaru G4 vanadium lithium ion battery. [13]

Choosing a battery should be decided by the size, weight, capacity are some considerations to be done. Subaru G4e is an electric vehicle developed in Japan makes use of vanadium lithium ion battery. The greatest advantage of this type of batteries is that it gives 200km of range. It takes 8 hours to charge from home ac power supply. A quick charge to 80% in just 15 minutes added a special feature to these vehicles. This battery size is of a brick block and can be placed underneath the passenger compartment. It's capacity of 346V.

As the output of the battery is a dc and should be converted to ac before it reach the motor side as it's the one which produce propulsion. The inverter is as shown below.

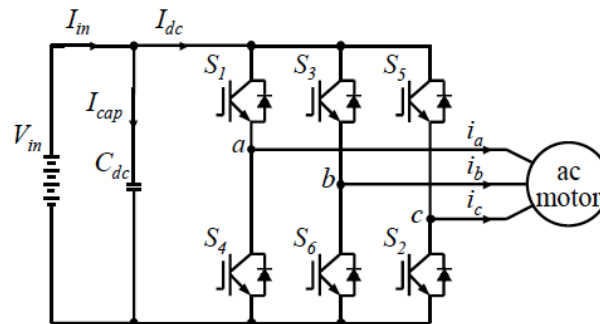

Fig.7 circuit of an inverter.[16]

Each section produces an alternating source. The output of all the side becomes a 3-phase and can be connected to the motor for further use.

The hybrid vehicle what we chose is parallel type. In this the IC engine and the motor are connected in parallel. Hence from either of the medium can be used to cause propulsion in the vehicle.

As mentioned earlier that alone solar can't be depended. Hence we need to choose an alternate. This can be fulfilled by the use of dynamos. This makes use the rotation of the wheels to generate electricity. This alone can't withstand the entire source. The backup part is obtained when brakes are applied, or in traffics, while climbing hills etc the excess energy which was supposed to be a waste is regenerated as heat. Hence this process is called regenerative braking.

The part of the battery output is connected to the li-ion battery as well as for other auxiliary uses.

V. SIMULATIONS

Since the PV cell is the main part as it's the one which generates main energy when there's no fuel to start. Hence we shall simulate the PV cell in the first place.

PV cell is implemented in the MATLAB software. This is implemented in the bases the respective equations.

The main equation is eq (1). The entire solar array is compressed in a subsystem. Inside the subsystem the respective equation's implementation is done inside.

This is as shown below.

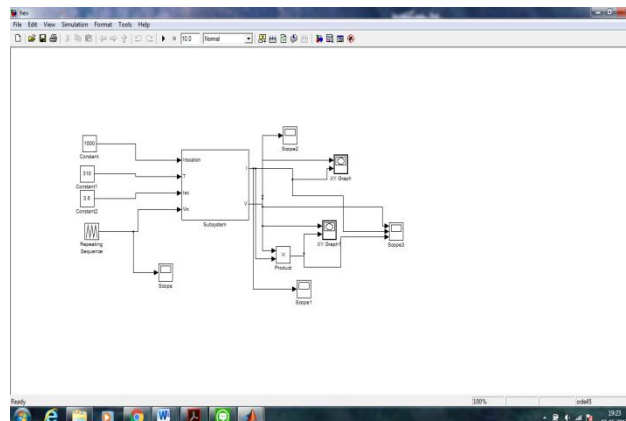

Fig. 8 circuit in MATLAB for PV cell

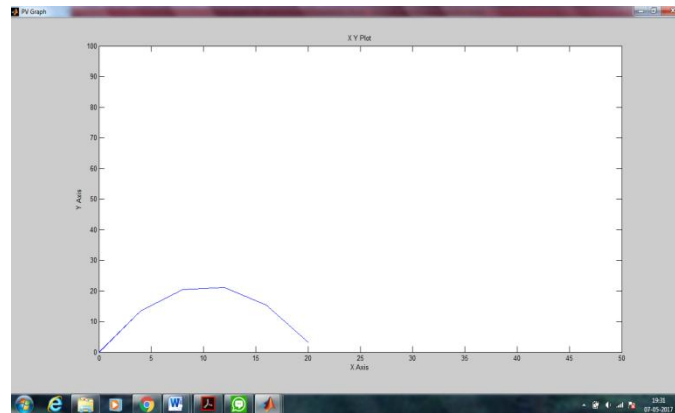

Fig. 9 PV characteristics of solar cell

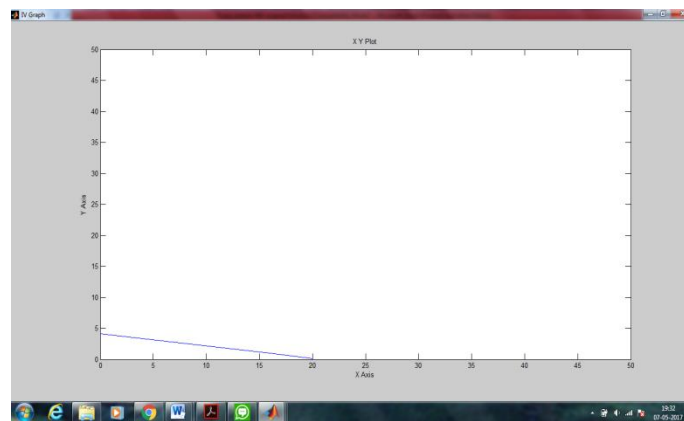

Fig. 10 IV characteristics of solar cell

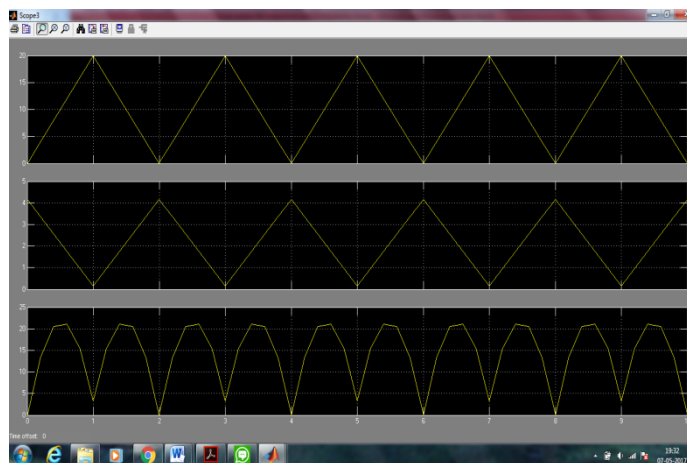

Fig. 11 waveforms of voltage, current and power

Voltage obtained from the PV cell is 20 volts.

Respected current I_{sc} is 3.8A

Hence from both the values we obtain the maximum power of 25W(for one cell).

In an solar panel consisting of 36 cells. Thereby we obtain the power of $25 \times 36 = 900W$.

From the simulations we can make out that the current is completely dependent on the temperature. Hence we obtain the maximum temperature by the afternoon and will be there for some time. Till that the maximum power is obtained. But the variations in dc should be maintained constant.



VI. COMPARISON OF NICKEL CADMIUM BATTERY AND LITHIUM ION BATTERY

TABLE 2 Comparison of nickel cadmium battery and lithium ion battery.[17]

DETAILS OF COMPARISON	NICKEL CADMIUM BATTERY	LITHIUM –ION BATTERY
ENERGY DENSITY		
<ul style="list-style-type: none"> Nominal cell voltage Voltage operating range Wh/kg Wh/L Size of 1KWh battery Weight of a 1KWh battery 	2.0V 1.8-2.1V 35-40 70 14liters 25kg	3.7V 3.2-4.1V 140-150 400 2.5liters 6.7kg
TEMPERATURE		
<ul style="list-style-type: none"> High temp survival /life reduction Low Temp (partial functionality) 	OK to 25C (77F) To -40C	OK to 60C(140F) To-25C
CHARGING		
<ul style="list-style-type: none"> Over chargeability Protection circuitry Constant charging rate in terms of C Recharging time duration Temp range of charge 	Tolerant(forms H2 gas) Inexpensive 0.007C rate 10 x the capacity -40C to +27C	Intorent - ventus Custom,expensive Crate(10x faster) 1 x the capacity -20 to +55
OPERATION		
<ul style="list-style-type: none"> Cycles At 10% discharge At 50% discharge At95% discharge	1750 500 250	4000+ 1000 500
COST		
<ul style="list-style-type: none"> Cell cost Maintenance cost Operating cost Air conditioning Service interval Replacement time frame 	Comparatively low High Required 6months 2years	Comparatively high Low Not required 12months 5-7 years

VII. ADVANTAGES OF LITHIUM- ION BATTERY

- a) High voltage in lithium ion battery over lead acid battery
- b) Greater energy density per unit weight
- c) Lighter /smaller providing more portability, less storage space, could even eliminate storage boxes
- d) Tolerates higher temperature, no air conditioning required
- e) Faster recharge time, and more time between recharges
- f) Higher turnaround charge efficiency
- g) More discharge cycles
- h) Deeper discharge tolerance
- i) State of health and state of charge can be readily and remotely monitored
- j) Longer time between service
- k) Replacement timeframe



VIII. DISADVANTAGES OF LITHIUM -ION BATTERY

- a) Li-ion protection circuitry is custom and expensive
- b) High maintenance cost
- c) Presence of high voltage may can be lethal
- d) It is not that robust as some other rechargeable batteries

IX. ADVANTAGES OF THREE WAY HYBRID VEHICLES

- a) Environment friendly- hybrid vehicle reduces carbon-di-oxide release and reduces the fuel dependency that will affect the climate.
- b) Financial benefits: - hybrid cars are supported by many credits and incentives that help to make them affordable, lower annual tax bills and exemption in the form of less amount of money spent on the fuel.
- c) Less dependence on fossil fuels:-a hybrid car is much cleaner and requires less fuel to run which means less emission and less dependence on fossil fuel.
- d) Regenerative breaking system:-each time you apply brake while driving a hybrid vehicle helps you to charge a battery for a little.
- e) Build from lighter vehicles:-hybrid vehicles are built from light materials which mean less energy is required to run.
- f) Use of solar panel gives efficient amount of energy to run the vehicle.
- g) Use of lithium ion rechargeable battery is another advantage .it limits the use of fossil fuel to run the vehicle.
- h) Use of dynamo gives a significant amount of energy, which can be used for axillary lighting purpose.

X. DISADVANTAGES OF THREE WAY HYBRID VEHICLES

- a) Can be expensive .This is one of the major disadvantages.
- b) Use of extra batteries can eat up the extra spaces in the vehicle.
- c) There is increase in weight which accounts in reducing the efficiency.
- d) As there is dual engine maintenance cost may increase
- e) Presence of high voltage batteries may cause damage in case of accidents.

All technologies have their advantages and disadvantages and hence 3 ways hybrid vehicle is no way different .hence as we know its benefits,it is possible to be able to work around them and utilize the technology.

FUTUTE SCOPE OF HYBRID VEHICLE

- a) In the present trend the future is mainly concerned on hybrid vehicles .it is estimated that by 2030 there would be a complete reduction in gasoline based vehicle and hence 3 way hybrid vehicle is best remedy.
- b) It is very eco-friendly vehicle and hence it is a better option for the future.
- c) Government of India have undertaken fame project just to promote hybrid vehicle innovation.
- d) As gasoline deposit is decreasing day by day use of 3 ways system hybrid vehicle is better option.

XI. CONCLUSION

From the above all sections and by the simulations, advantages , disadvantages, futerscope, and mainly the future availability of the resources we can conclude that by some other modifications we can obtain even better efficiency as well as the maximum power.

PV cells: from the simulations what we have obtained shows that the maximum power obtained can be of nearly 25W. This is for single cell and when calculated for the entirepanel reaches for 900W.

Lithium ion battery: this from the inspiration of Subaru company product as it posses certain attractive features we had taken this battery.

Dynamos: this has added an extra power by taking the rotational energy into account. Thereby increasing the efficiency of the car with respect to the mileage.

Though the cost is a bit high, keeping in the mind of future problems as well as the ecological problem we need to compromise with it.



REFERENCES

- [1] Patel Abhishek, concept and theory on three way hybrid vehicle with the present emerging technology.
- [2] C.C.Chan, Fellow, IEEE, Alain Bouscayrol Member, IEEE, "Electric Hybrid, and Fuel cell vehicles Architectures and modeling", IEEE transactions on vehicles technology, vol-59, no 2 February 2010
- [3] "Electric Vehicle Technology Explained"- James Larminie, Oxford Brookes University, Oxford, UK, John Lowry, Acenti Designs Ltd., UK
- [4] M.S Spina, R.J. De La Vega, S.R. Rossi, G. Santillan, R.C. Leegstra, C. Verucchi, F.A. Gachea, R.E. Romero, G.G. Acosta, "Some issues on the design of the solar vehicle based on hybrid energy system", International Journal of energy eng 2012
- [5] "Low cost hybrid solar car concept" International conference on current research in engineering science and technology [ICCREST] 2016
- [6] Battery university, POPE STASET SCIENTA
- [7] Nissan Motor corporation electric vehicle lithium ion battery technology.
- [8] T. Allen Prasad, Lokesh Ramesh, "Powering the Electric Cars with Dynamos", ISOR Journal of Mechanical and Civil Engineering (ISOR-JMCE), ISSN: 2278-1684 Volume 3. Issue 2(Sep-Oct 2012), PP 01-05, www.iosrjournals.org
- [9] "A detailed modeling of photovoltaic module using MATLAB " National Research Institute of Astronomy and Geophysics NRIAG Journal of Astronomy and Geophysics
- [10] XuanHieu Nguyen and Minh Phuong Nguyen "Mathematical modeling of photovoltaic cell/module/arrays with tags in Matlab/Simulink", Nguyen and Nguyen Environ Syst Res (2015) 4:24 DOI 10.1186/s40068-015-0047-9
- [11] https://www.google.co.in/search?q=pv+cell+design&source=lnms&tbm=isch&sa=X&ved=0ahUKEwjp7aPMId7TAhVErI8KHSWgDRgQ_AUIBigB&biw=1366&bih=638#imgrc=nqsljOqsZqw2JM:
- [12] https://www.google.co.in/search?q=pv+cell+design&source=lnms&tbm=isch&sa=X&ved=0ahUKEwjp7aPMId7TAhVErI8KHSWgDRgQ_AUIBigB&biw=1366&bih=638#tbm=isch&q=solar+cell+equivalent+circuit&imgrc=xr5WLduqmarTkM:
- [13] https://www.google.co.in/search?q=pv+cell+design&source=lnms&tbm=isch&sa=X&ved=0ahUKEwjp7aPMId7TAhVErI8KHSWgDRgQ_AUIBigB&biw=1366&bih=638#tbm=isch&q=+vanadium+lithium+ion+battery&imgrc=DABVYIKe-JLybM:
- [14] <https://science.nasa.gov/science-news/science-at-nasa/2002/solarcells>
- [15] <http://sustainable-nano.com/2013/10/15/how-do-lithium-ion-batteries-work/>
- [16] https://www.google.co.in/search?q=inverter+circuit+for+motor&source=lnms&tbm=isch&sa=X&ved=0ahUKEwjmjCIx-DTAhXCOI8KHRf_AVoQ_AUIB&biw=1366&bih=638#imgrc=JayafiGkImm9HM:
- [17]]Lan-Rong Dung 1,*, Hsiang-Fu Yuan 2,*, Jieh-Hwang Yen 2, Chien-Hua She 3 and Ming-Han Lee 1." A Lithium-Ion Battery Simulator Based on a Diffusion and Switching Overpotential Hybrid Model for Dynamic Discharging Behavior and Runtime Predictions", Received: 14 October 2015; Accepted: 7 January 2016; Published: 18 January 2016 Academic Editor: K. T. Chau