

# Instantaneous Buck Boost Converter with better Transient effect for battery Power Applications using Micro-Controller

Akshay.P<sup>1</sup>, Divya K Pai<sup>2</sup>

Student, Electrical & Electronics Department, St. Joseph Engineering College, Mangaluru, India<sup>1</sup>

Assistant Professor, Electrical & Electronics Department, St. Joseph Engineering College, Mangaluru, India<sup>2</sup>

**Abstract:** A transitional grouping mode of control is introduced using microcontroller for the buck boost converter. A constant output voltage is obtained by applying an input voltage from 8V to 14V along with increase in saturation. The price, efficiency, decrease in wrinkle in the waveform and voltage across the load can be superior. By introducing combination A and B between the three modes with better transient response which reduces the distortions in the output voltage. By using all the transitional combination mode, a ripple content will be decreased and efficiency can be better in the regulated output voltage.

**Keywords:** Combination Mode, Efficiency, Micro Controller, Saturation, Transitional.

## I. INTRODUCTION

Obtaining a constant output voltage from a variable input along with increase in saturation is a very ordinary power-handling crisis, mainly for handy applications (power-driven by battery) like mobile set, personal digital assistants (PDAs), WI-FI modems (Wireless Fidelity), and advanced cameras. While the battery supply is either charged or discharged, the supply can increase, decrease or becomes equal to the output voltage. For a small size application, it is necessary to control the output voltage of the converter with high accuracy and operation. As a result, a transaction between the price, efficiency, and output transients must be measured. For a space controlled applications, a ordinary power-handling crisis power-driven by a battery is a regulation of voltage at the load is in the midrange of a variable input battery supply.

The use of a buck and boost converter can be lined out for an voltage applied in the range that is higher and lower than the voltage at the load unless it is cascaded. The use of this cascaded combination in converters that can result in cascaded losses and price. As a result, this method is rarely used. In such variety of power requirements, the changeover of dc voltage from one stage to other is normally capable by a process chopper circuits. For a power supplies with low-voltage-range, the essential points of concerns are wrinkles in the output waveform, efficiency, gap, and the price. For such power supplies the above said concerns are usually not implemented because of their lower efficiency, greater size, and price factors.

At the time of transition from boost mode to the buck mode, the spikes in the output voltages is the most difficult problem that makes the converter to reduce its efficiency. Price, size, switching speed, efficiency, and flexibility every things required to be known while designing such power supplies.

## II. MODELLING OF BUCK-BOOST CONVERTER

### A. Disadvantages of a common Buck-Boost Converter

A major difficulty related with the common buck-boost converter is the converter output is reversed. anyways it can be reversed, but it requires a transformer, that gets added to a price and space and sacrifice the converter efficiency.

### B. Demerits by Using SEPIC Converter

The single ended primary inductance converter is a familiar buck-boost topology it needs additional components but produces a constant output. It has restricted efficiency and needs either two inductors or a transformer.

Thus, improve the size and price. Using of such components will result in losses, so it degrades the converter efficiency.

**III. INSTANTANEOUS BUCK-BOOST CONVERTER**

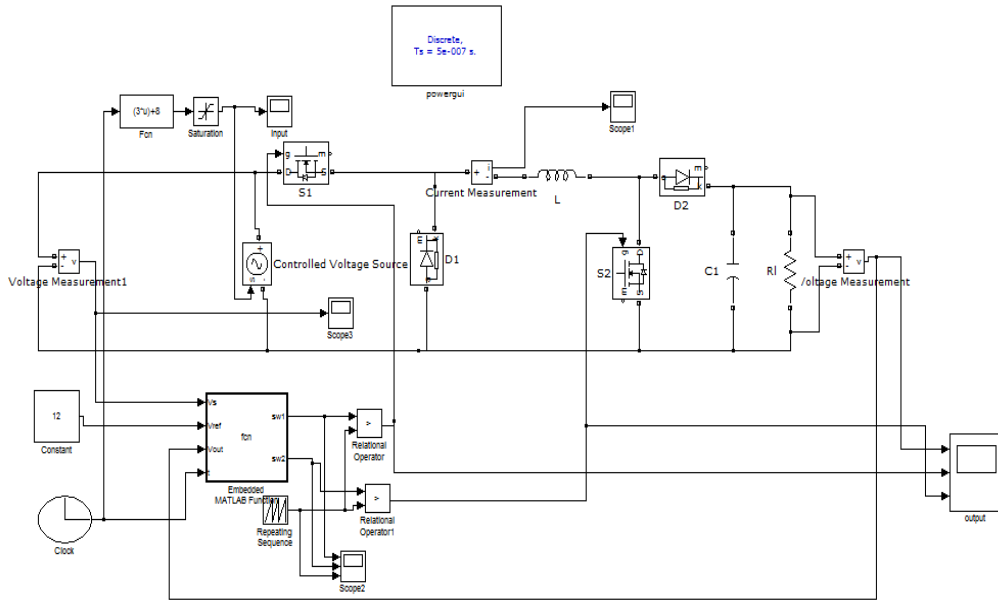

Fig.3 Instantaneous buck–boost converter

The circuit diagram of an Instantaneous buck–boost converter is shown in figure.3 In this circuit for the operating mode two MOSFET switches and diodes are used. The MOSFET switches used is IRF540 and diodes used is 1N5817, correspondingly. The Micro Controller is being implemented using a 8051. The operational modes works on the mode selection commands, applied from Micro Controller. The converter output is always a positive. Here there are 3 working cases of MOSFET switches. Case1:When MOSFET switch 1 is ON and switch 2 is completely OFF it will be operating in a Buck mode. Case2: When MOSFET switch 1 as well as switch 2 both are ON it will be operating in a Buck-Boost mode. Case3: When MOSFET switch 2 is ON and switch 1 is ON or OFF it will be operating in a Boost mode. In this Method the constant output voltage is to set to 12V. The inputs are given as a variable input ranging from 8V to 14V. The input voltage which is higher than the constant output voltage 12V, The converter operates in a Buck mode with Switch 1 ON. The input voltage becomes equal to the reference voltage 12V the converter operates in a Buck-Boost mode with both the switches 1 & 2 are ON. The input voltage which is lower than the reference voltage 12V, the converter operates in Boost mode with the switch 2 ON.

**IV. SIMULATION RESULTS**

**A. Transition from boost to buck mode.**

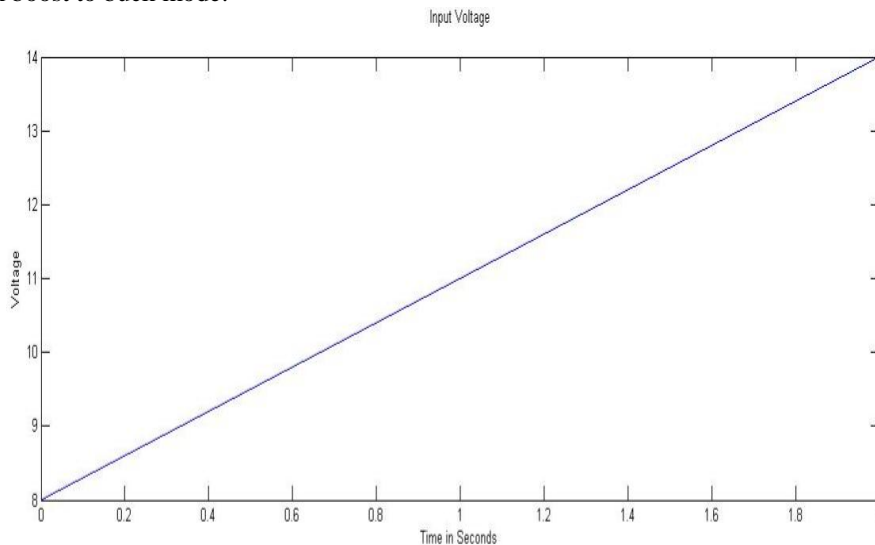

Fig.4.1 Input voltage

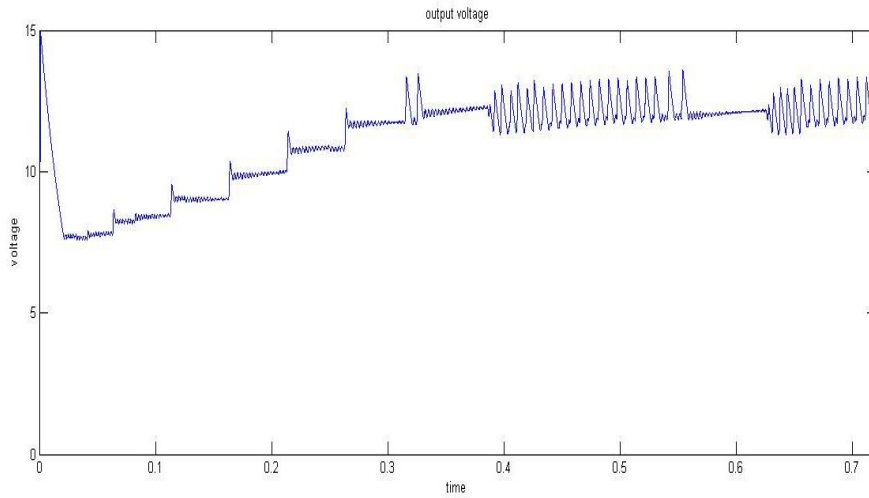

Fig.4.2 Output voltage of transition from boost to buck mode

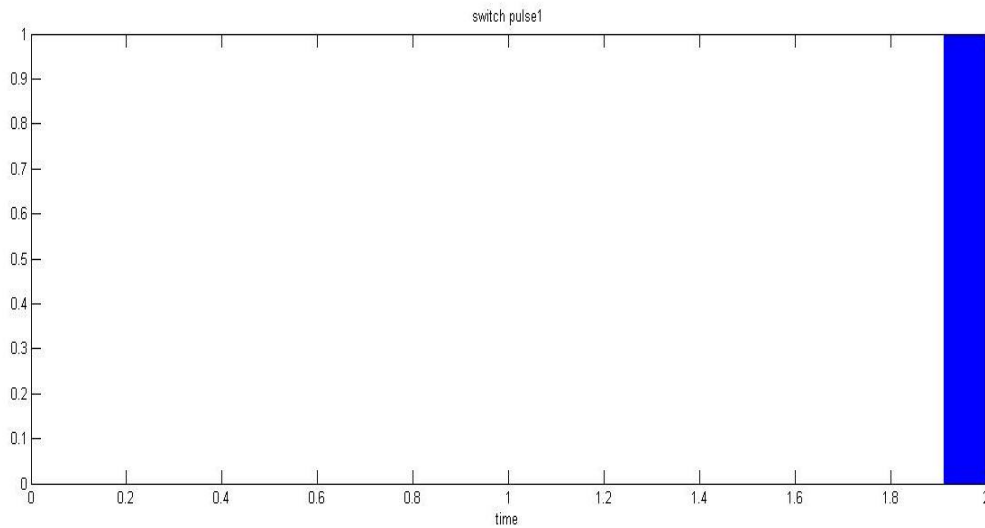

Fig 4.3 Pulse for Switch 1

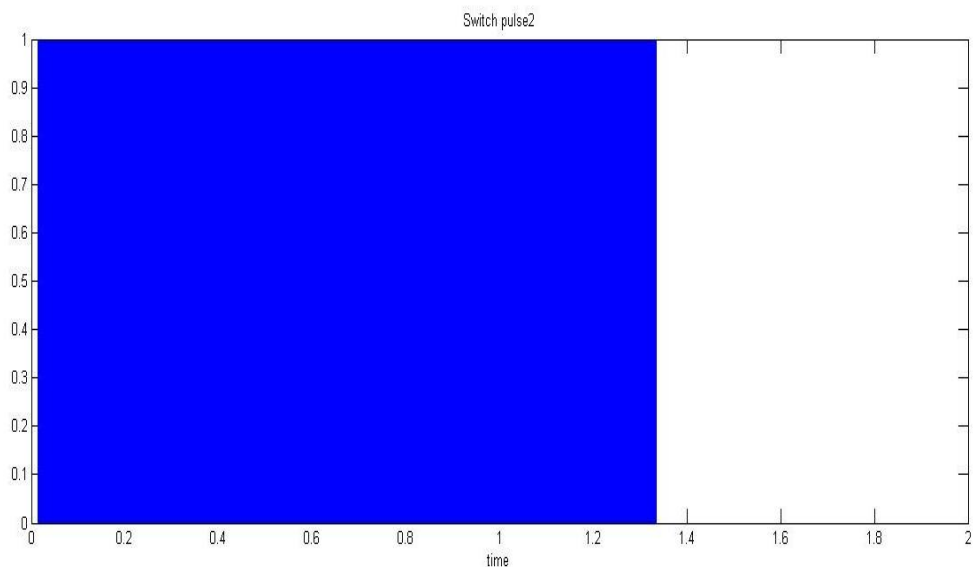

Fig 4.4 Pulse for switch 2

The above figure 4.1 shows Input voltage for direct transition from boost to buck mode from 8v to 14v which is a rise in saturation. In figure 4.2, there is a ripple in the output voltage of about 12%-14% at the time of direct transition from boost to buck mode. At the time of this mode of operation, the both MOSFET switches 1 & 2 will be operating at the same time, The boost-buck mode, in the centre is ignored to save the converter efficiency. Pulses in the switch 2 is boost operating mode till the 1.35A. Switch 1 is kept permanently ON. After the boost mode it works as a buck mode with 100% duty cycle and there will be pulses for switch 1 which works as a pure buck mode till the end.

### B. Transition from boost to buck-boost and then to buck mode.

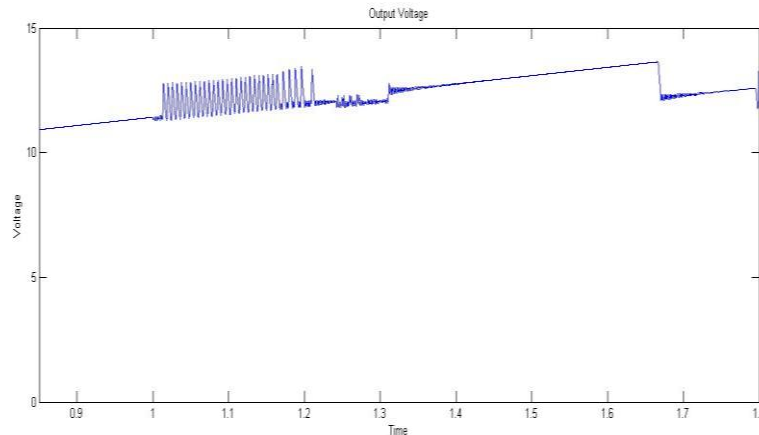

Fig.4.5 Output Voltage of Transition from boost to buck-boost and then to buck mode with switch pulses

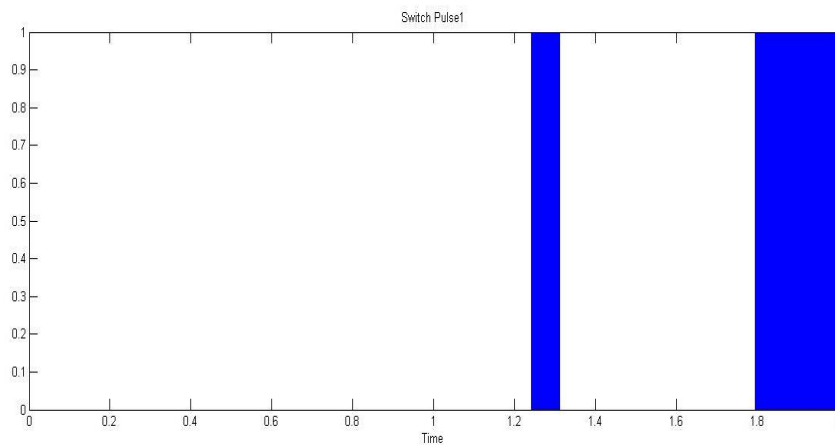

Fig 4.6 Pulse for switch 1

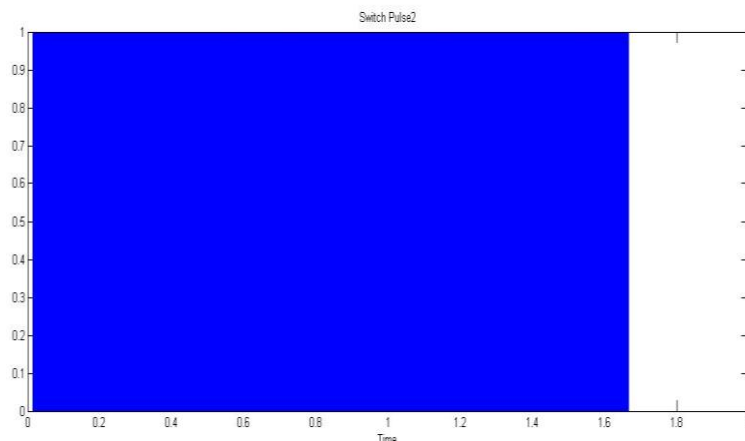

Fig 4.7 Pulse for switch 2

The above figure shows the transition from boost to buck–boost and then to buck mode with switch pulses and same input voltage is applied with rise in saturation from 8v to 14v. In this mode of operation in switch 2 there will be pulses which acts as boost mode till 1.25A. Pulses with both the switches from 1.25A to 1.32A acts a Buck-Boost mode with input voltage equal to output voltage. In switch 2 there will be again pulses acting as a boost operating mode. In this transitional mode also Switch 1 is kept permanently ON. After the boost mode it works as a buck mode with 100% duty cycle and there will be pulses for switch 1 which works as a pure buck mode till the end.

#### IV. CONCLUSION

A transition of instantaneous buck–boost converter is being shown with a greatly enabling control scheme of PWM. This future controller system is able to control a constant output voltage for a variable input voltage, depending on the charge position of a battery power. The system introduced in this paper is very different in getting better efficiency at a equal instant which reduces the wrinkles in the constant output waveform for an instantaneous Buck-Boost converter when the pure transition is required from the boost to buck mode.

#### ACKNOWLEDGMENT

I wish to express my sincere gratitude to my Guide Mrs. Divya K Pai for her valuable guidance and suggestions hence improving myr knowledge. I am indebted to our respected Principal, Dr. Joseph Gonsalvis, beloved Director Rev. Fr. Joseph Lobo and the Management of St. Joseph Engineering College, Vamanjoor, Mangalore for having provided all the facilities that helped us in timely completion of the this paper. Finally I would like to thank all the staff members of Electrical & Electronics Dept of St. Joseph Engineering college.

#### REFERENCES

- [1]. A. Chakraborty, A. Khaligh, A. Emadi, and A. P faelzer, "Digital combination of buck and boost converters to control a positive buck-boost converter," in Proc. IEEE Power Electron. Spec. Conf., Jun. 2006, vol. 1, pp. 1-6.
- [2]. A. Chakraborty, A. Khaligh, and A. Emadi, "Combination of buck and boost modes to minimize transients in the output of a positive buck-boost converter," in Proc. IEEE 32nd Ind. Electron. Annu. Conf., Paris, France, Nov. 2006, pp. 2372-2377.
- [3]. R. W. Erickson, Fundamentals of Power Electronics, 4th ed. Norwell, MA: Kluwer, 1999.
- [4]. B. Sahu and G. A. Rincon-Mora, "A low voltage, dynamic, non inverting, synchronous buck-boost converter for portable applications," IEEE Trans. Power Electron., vol. 19, no. 2, pp. 443-452, Mar. 2004.
- [5]. B. Bryant and M. K. Kazimierzuk, "Derivation of the buck-boost PWM DC-DC converter circuit topology," in Proc. Int. Symp. Circuits Syst., May 2002, vol. 5, pp. 841- 844.
- [6]. Y. Zhang and P. C. Sen, "A new soft-switching technique for buck, boost, and buck-boost converters," IEEE Trans. Ind. Appl., vol.39, no. 6, pp. 1775-1782, Nov./Dec. 2003.
- [7]. C. Jingquan, D. Maksimovic, and R. Erickson, "Buckboost PWM converters having two independently controlled switches," in Proc. IEEE 32nd Power Electron. Spec. Conf., Jun. 2001, vol. 2, pp. 736-741.
- [8]. D. Adar, G. Rahav, and S. Ben-Yaakov, "A unified behavioral average model of SEPIC converters with coupled inductors," in Proc. IEEE Power Electron. Spec. Conf., Jun. 1997, vol. 1, pp. 441-446.
- [9]. W. M. Moussa, "Modeling and performance evaluation of a dc/dc SEPIC converter," in Proc. IEEE Appl. Power Electron. Conf., Mar. 1995, vol. 2, pp. 702-706.