

# Quasi-Z-Source Solar Inverter Fed BLDC Drive using ANFIS MPPT Control

Dr.T.Govindaraj<sup>1</sup>, K.Hemalatha<sup>2</sup>

Professor and Head, Department of EEE, Muthayammal Engineering College, Rasipuram, Tamilnadu, India <sup>1</sup>

PG Scholar, Power Electronics and Drives, Muthayammal Engineering College, Rasipuram, Tamilnadu, India <sup>2</sup>

**Abstract:** The major players in renewable energy generation are photovoltaics (PV), wind farms, fuel cell, and biomass. These distributed power generation sources are widely accepted for microgrid applications. However, the reliability of the microgrid relies upon the interfacing power converter. This paper proposes an artificial-intelligence-based solution to interface and deliver maximum power from a photovoltaic (PV) power generating system in standalone operation. BLDC motor is connected at the output side which acts as a load and efficiently utilizes the power obtained from solar using ANFIS. The qZSI acts as the interface in between the PV dc source and the BLDC motor. ANFIS promises the maximum power delivery to the load based on maximum power point tracking (MPPT). The proposed ANFIS-based MPPT offers high efficiency and accuracy. The closed loop control regulates the speed of the BLDC motor for different load conditions and also maintains regulated voltage and current. The effectiveness of this proposed method is verified using matlab/simulink software.

**Key words:** quasi-Z-source inverter (qZSI), Adaptive neuro fuzzy inference system (ANFIS), Solar power generation.

## I. INTRODUCTION

THE WORLD pays growing attention to the renewable, clean, and practically inexhaustible energy sources such as Photovoltaic (PV) [3], wind, tidal, Geothermal energy. Among these PV energy is a main and appropriate renewable energy, owing to the merits of clean, quiet, pollution free, and abundant. Photovoltaic (PV) installations are a familiar reference in this landscape, ranging from small (less than 5 kW) residential plants to larger (thousands of kilowatts) grid-connected PV fields. Maximum power point tracking (MPPT) is used here to get the maximum possible power from photovoltaic device [7],[11]-[16]. Solar cells have a complex relationship between solar irradiation, temperature and total resistance that produces a non-linear output efficiency which can be analyzed based on the I-V curve as shown in the Fig. 1. It is the purpose of the MPPT system to sample the output of the cells to obtain maximum power for any given environmental conditions. For MPPT control commonly used techniques are Perturb and Observe (PO), Incremental Conductance Technique (ICT), and constant voltage where these techniques suffers with the oscillation of power output around the maximum power point and increased computation time even under steady state illumination. Thus this paper proposes ANFIS techniques to determine the maximum power capability of a PV module for variable solar irradiance and temperature conditions. The ANFIS integrates the neural network and fuzzy logic [9], thus this synergy offers the most powerful artificial intelligence technique.

Artificial intelligence (AI)-based methods are increasingly used in renewable energy systems due to the flexible nature of the control offered by such techniques. The AI techniques

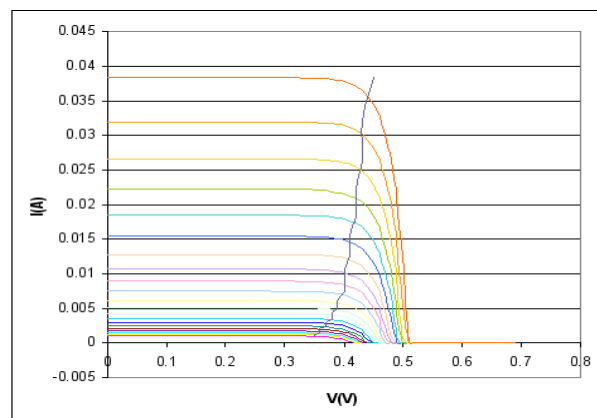

Fig. 1. Solar I-V curve

are highly successful in nonlinear systems due to the fact that once properly trained they can interpolate and extrapolate the random data with high accuracy. Voltage and current are taken as the input to the ANFIS[4] controller. In contrast, the presented technique utilizes the weather information as the input to the ANFIS where BLDC[2][10] motor is driven from the output of qZSI[1][5]. The proposed

technique of using ANFIS-based MPPT offers highly precise and fast control with robust operation and is highly suitable for standalone operation in PV generation systems.

## II. SYSTEM ANALYSIS

In existing system the conventional inverter is oversized to cope with the wide PV array voltage changes because a PV panel presents low output voltage with a wide range of variation based on irradiation and temperature, usually at a range of 1 : 2 hence to interface the low voltage output of an inverter to the load, a bulky low frequency transformer or boost dc/dc converter is used where both requires galvanic isolation. Galvanic isolation increases the cost and size of whole system with reduced efficiency. It also uses perturb and observe, Incremental conductance methods are used to track maximum power point which suffers by oscillations to track maximum power point where accurate MPP cannot be achieved through this. The output has been given to the grid alone without any isolated load condition such as three phase load.

Quasi-Z-source inverter (qZSI) topology has been introduced recently to overcome some of the shortcomings of the Z-source inverter. The qZSI offers several advantages over the Z-source inverter such as continuous input current, reduced components rating, higher reliability, and simple control strategy. This topology of the inverter is identified as one of the most suitable power conditioning interface between the PV generation system and the grid. This paper presents an improved power circuit topology of qZSI where one capacitor of the quasi-Z-source network is replaced by storage batteries, thus flexible power conditioning functionalities can be achieved. In the proposed structure, the load can be isolated or it can be a micro grid or a full scale grid. Given the condition that the battery is within its valid charge or discharge status, MPPT can be accomplished by sending the captured extra power – to the battery, or the output power can be maintained for period of time by extracting absent power – from the battery. It is much important for large-scale PV systems interfacing the power grid, where stable and sustainable energy supply is always demanded, while contrastively PV cell's output power varies accordingly with temperature and solar irradiation.

The objectives to be achieved by the proposed control system are

1. Maximum power point tracking using ANFIS
2. The ANFIS for giving voltage output crisp value corresponding to the maximum power delivery from the PV panels
3. Desired stable output power to the BLDC motor.
4. Flexible power conditioning functionalities achievement.
5. The load can be isolated or it can be a micro grid or a full scale grid.

There are two control variables for the qZSI control system, i.e., the shoot-through duty and modulation index Both control variables should cooperate to achieve the above set goals.

## III. ANFIS BASED CONTROL OF BLDC

In the proposed system Adaptive neuro fuzzy inference system is used to track the maximum power from solar PV panel and this obtained power is used to run the BLDC motor [2] through quasi Z source inverter. Closed loop control is achieved using PIC so that speed of the BLDC motor can be maintained constant even under load changing condition.

### A. BLOCK DIAGRAM OF PROPOSED CONTROL SCHEME

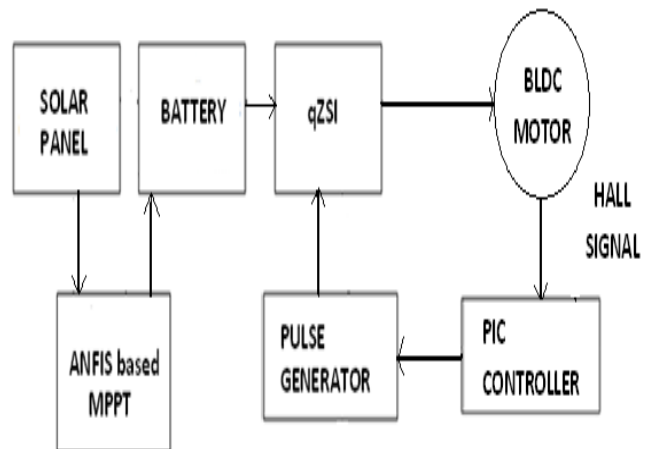

Fig. 2. Block diagram of proposed system

It consist of solar panel, battery, qZSI, ANFIS MPPT controller, BLDC with hall sensor and pulse generator to control the operation of BLDC motor as shown in the Fig.2. where ANFIS technique places a major role in tracking maximum power and helps to supply constant input to quasi Z source inverter. Solar panel is used as the input source, it absorbs energy from sunlight and converts it into electricity. Battery is used to store the energy. There are many methods to track maximum power but the proposed ANFIS based MPPT offers an extremely fast dynamic response with high accuracy. By hybrid learning procedure it can construct an input-output mapping based on both human knowledge i.e., in the form of fuzzy if-then rules and stipulated input output data pairs. In the simulation, the ANFIS architecture is employed to model nonlinear functions and yields



remarkable results. DC output from the battery is given to quasi Z source inverter. qZSI is a new promising power conversion technology perfectly suitable for interfacing of renewable (i.e., photovoltaic, wind turbines) and alternative (i.e., fuel cells) energy sources. This paper presents an improved power circuit topology of qZSI, its advantages are

1. Boost-buck function by the one-stage conversion.
2. Continuous input current (input current never drops to zero, thus featuring the reduced stress of the input voltage source, which is especially topical in such demanding applications as power conditioners for fuel cells and solar panels).
3. Excellent reliability due to the shoot-through withstanding capability.
4. Low or no in-rush current during start up.
5. Low common-mode noise.

**B. BRUSHLESS DC MOTOR**

In the brushless DC motor, polarity reversal is performed by power transistors switching in synchronization with the rotor position. Therefore, BLDC motors often incorporate either internal or external position sensors to sense the actual rotor position, or the position can be detected without sensors. Commutation provides the creation of a rotation field. It is necessary to keep the angle between stator and rotor flux close to 90° for a BLDC motor to operate properly. Six-step control creates a total of six possible stator flux vectors. The stator flux vector must be changed at a certain rotor position.

TABLE I  
Emf generation according to the hall signal

ha	hb	hc	emf-a	emf-b	emf-c
0	0	0	0	0	0
0	0	1	0	-1	+1
0	1	0	-1	+1	0
0	1	1	-1	0	+1
1	0	0	+1	0	-1
1	0	1	+1	-1	0
1	1	0	0	+1	-1
1	1	1	0	0	0

The rotor position is usually sensed by Hall sensors. The Hall sensors generate three signals that also comprise six states. Each of Hall sensors' states corresponds to a certain

stator flux vector. All Hall sensor states with corresponding stator flux vectors. The switching states of qZSI is shown in the table.

TABLE II  
Switching states of Qzsi

emf-a	emf-b	emf-c	Q1	Q2	Q3	Q4	Q5	Q6
0	0	0	0	0	0	0	0	0
0	-1	+1	0	0	0	1	1	0
-1	+1	0	0	1	1	0	0	0
-1	0	+1	0	1	0	0	1	0
+1	0	-1	1	0	0	0	0	1
+1	-1	0	1	0	0	1	0	0
0	+1	-1	0	0	1	0	0	1
0	0	0	0	0	0	0	0	0

Since a permanent magnet rotor is used in a BLDC the speed control can be implemented by varying the average voltage across the stator windings. This tends to change the value of the average stator current. However for a given load torque the average stator current has to be ideally fixed. Hence the back EMF induced in the stator windings has to change such that the stator current remains constant. For a constant field the speed will be changed. Thus increasing the applied stator voltage increases the motor speed and vice-versa. Variation in the motor voltage can be achieved using several techniques which can be broadly divided in to sensed control and sensor less control. Here sensor control is used with the use of hall sensor. Usage of semiconductor switches is preferred due to their low loss, high frequency operation and the allowance for electronic control. This is apart from the other advantages like space and cost saving. The typical inverter drive system for a BLDC motor is shown in Fig. 3

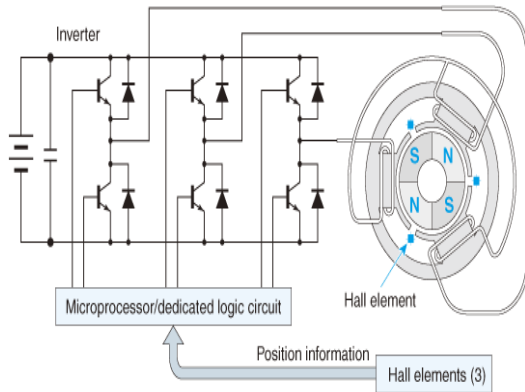

Fig. 3. Typical inverter drive system for a BLDC motor

As seen from Fig. 3. the output stage consists of a three-phase inverter composed of switches that could be MOSFETs or IGBTs. Here IGBTs are used. Brushless-dc machine operation requires rotor position information to allow for appropriate solid state switch firing. For sensored control, three leading technologies are commonly used to fulfil the position information requirement. These technologies are hall-effect sensors, resolvers, and optical encoders. The most commonly used sensor type is a Hall Effect sensor. They are low cost and provide position resolution to within thirty electrical degrees, which is sufficient to operate a BLDC machine. The major advantages of BLDC motor are

1. It has 3 times longer life than brushed motor
2. Spark free operation is possible with safe and less radio interference
3. Electronic and frictional noise are absent
4. No brush friction, so power consumed is 28% less than brushed motors, based on the same output
5. No commutator or brushes to wear out.

### C. PROPOSED CIRCUIT

The circuit diagram of qZSI fed BLDC motor with ANFIS technique. Here the ANFIS and qZSI places a major part, where output from inverter is effectively utilized for driving a BLDC motor, and further control of motor is done with the help of gate pulse generation by pulse generator accordingly, through hall sensor placed at the rotor side. It effectively senses the rotor position and hall signals are converted to emf by decoder. According to the value of emf fed, the gating signal produced by pulse generator differs and hence speed of the motor can be controlled.

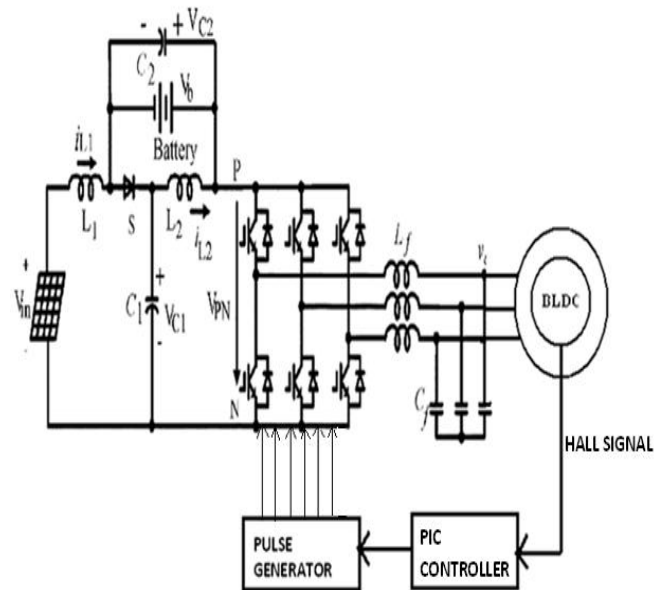

Fig. 4. Circuit diagram of proposed scheme

This topology of the inverter is one of the most suitable power conditioning interface between the PV generation system and the load. In order to capture the maximum solar energy, MPPT is necessary to draw the maximum power PMPP from the PV panels in PV applications, which is commonly implemented by regulating the PV voltage to follow a time-variant reference the voltage of the maximum power point VMPP.

The value of VMPP is continuously tracked by ANFIS. On the other hand, the output power is another concern of the PV system. For an isolated load condition, the output voltage of the qZSI is regulated and the output power is determined by corresponding load demands. While for a grid-interactive condition, the output power of the qZSI can be regulated by controlling the current injected to the grid accordingly.

### IV. PRINCIPLE OF OPERATION

The output power to loads along with the power absorbed or released by energy storage battery here, should be matched to maintain a stable and sustainable operating approach, and it is the battery that provides an energy buffer zone for both input and output sides of the PV system. Given the condition that the battery is within its valid charge or discharge status, MPPT can be accomplished by sending the captured extra power to the battery, or the output power can be maintained for period of time by extracting absent power – from the battery. The second case is of essential importance for large-scale PV systems interfacing the power grid, where stable and sustainable energy supply is always demanded, while contrastively PV cell's output power varies accordingly with

temperature and solar irradiation. With the proposed topology, the state-of-charge (SOC) of the battery is taken into consideration with the following concerns. To choose a proper shoot-through duty ratio for regulating to, and the battery is charged or discharged through a desired current, which is determined by the power difference of input and output together with the battery voltage, and also is limited by the maximum acceptable value according to the battery. Once the battery has been adequately charged, the voltage of the battery in the circuit should be regulated as little current charging the battery any longer. In this situation MPPT may not be achieved because the energy buffer zone is unable to absorb extra power. If the battery is exhausted where the battery voltage drops below one threshold and there is still a shortage of power from PV panels, load shading needs to be executed. For all the above-mentioned statuses, a sufficient dc bus voltage should be kept for a valid output. In order to satisfy this requirement, MPPT may be sacrificed for the sake of an adequate voltage boost.

$$VC1 = \frac{(1-D)V_{pv}}{1-2D} \quad (1)$$

$$VC2 = \frac{(D)V_{pv}}{1-2D} \quad (2)$$

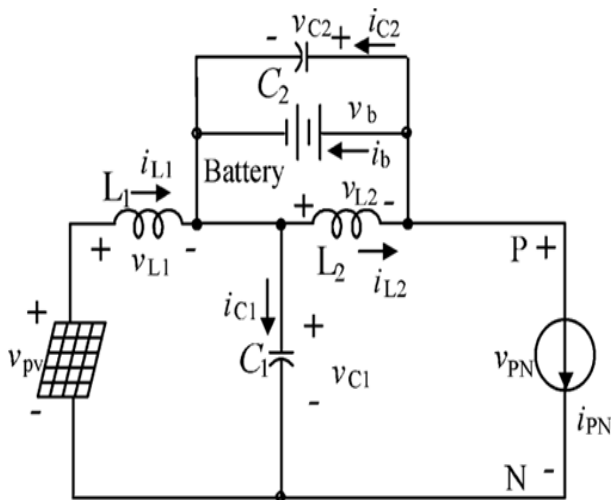

Fig. 4. Equivalent circuit of qZSI with battery

$$iL1 = \frac{D \cdot ib + (1-D) \cdot iPN}{1-2D} \quad (3)$$

$$iL2 = \frac{(1-D) \cdot ib + (1-D) \cdot iPN}{1-2D} \quad (4)$$

The dc-link peak voltage  $V_{PN}$  could be derived from the sum of two capacitor voltages, from equation (1) and (2)

$$V_{PN} = VC1 + VC2 \quad (5)$$

The relationship between two inductor currents  $iL1$  and  $iL2$  the current flowing into the battery  $ib$  is shown as

$$iL2 - iL1 = ib \quad (6)$$

The average power relationship of the system during one switching cycle is derived as follows:

The PV output power could be calculated by

$$P_{pv} = V_{pv} \cdot i_{pv} = iL1 \cdot V_{pv} \quad (7)$$

The power of battery can be calculated by

$$P_{battery} = V_b \cdot i_b = i_b \cdot VC2 \quad (8)$$

The load power can be expressed by

$$P_{load} = V_{pn} \cdot i_{pn} \\ = (1 - D)V_{pn} \cdot i_{pn}$$

The power relationship in the system can be derived as

$$P_{pv} - P_{load} = P_{battery} \quad (10)$$

The qZSI can buck or boost input dc voltage, it can handle wide variation of the input voltage, particularly for the PV system, and produce a desired voltage for the isolated load or for the grid in a single stage. This feature results in the reduced number of switches involved in the power electronics of the PV system and, therefore, the reduced cost and the improved system efficiency and reliability. When the solar irradiance is low and the PV panel produces low voltage, the qZSI boosts the voltage, which helps to avoid redundant PV panels for higher dc voltage or unessential inverter overrating. As mentioned previously, it is able to handle the shoot-through state; therefore, it is more reliable than the conventional VSI. Additionally, for the qZSI, there is a common dc rail between the source and inverter, which is easier to assemble and causes less EMI problems

In the proposed control strategy, a closed-loop control of the input voltage  $V_{mpp}$  is combined with the trained ANFIS to implement the MPPT control. In general, the battery voltage depends on its SOC, instead of its current, and has a little change in a suitable range of the SOC. At constant temperature, the change of solar irradiation will result in a great change of PV current at the maximum power point (MPP), when compared to the resultant change of PV voltage. The MPPT control could ensure a stable peak dc-link voltage with little variation at a constant temperature. On the other hand, the change of temperature will result in a great change of PV voltage at the MPP, when compared to the resultant change of PV current, which will make the peak

dc-link voltage change greatly. In the load side, the closed-loop control is employed to keep the output voltage magnitude and frequency constant regardless of the change in the input conditions. The outputs of the solar irradiance and temperature transducers are current/voltage signals which are logged in real time using standard data loggers. These data are then be transferred to the PC for further processing or implementation of real-time control system using the ANFIS controller.

## V. SIMULATION AND RESULTS

To validate the proposed control scheme, the simulated model is developed in Matlab/Simulink for the whole system. The PV cell temperature varies from 10 C to 70 C in a step of 6 C and the solar irradiance varies from 50 to 1000 W/m in a step of 50 W/m . By varying these two environmental factors a set of data is generated in simulation which is used to train the ANFIS network for the purpose of MPPT. The training is done offline using Matlab tool box. The overall neuro-fuzzy structure shown in Fig. 6 is a five-layer network. The structure shows two inputs of the solar irradiance and the cell temperature, which is translated into appropriate membership functions. These membership functions are generated by the ANFIS controller based on the prior knowledge obtained from the training data set. The membership function's shape varies during the training stage and the final shape obtained after the completion of the training. Considering a real situation, the solar irradiance varies from a certain minimum value to the maximum value and then goes down to another minimum value. A similar pattern is also suitable for the PV cell temperature.

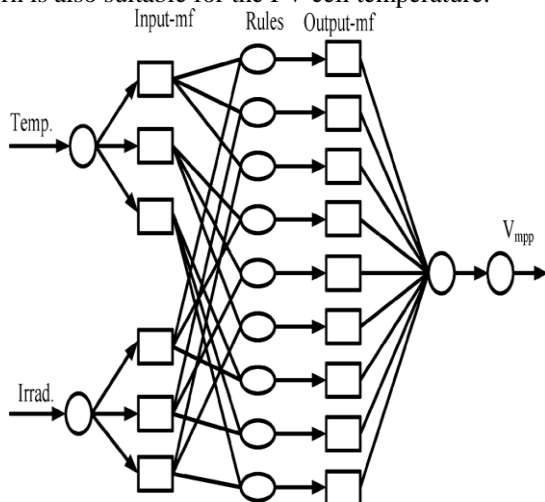

Fig.6. ANFIS based MPPT structure

To simulate a real time scenario, the solar irradiance and temperature is varied accordingly

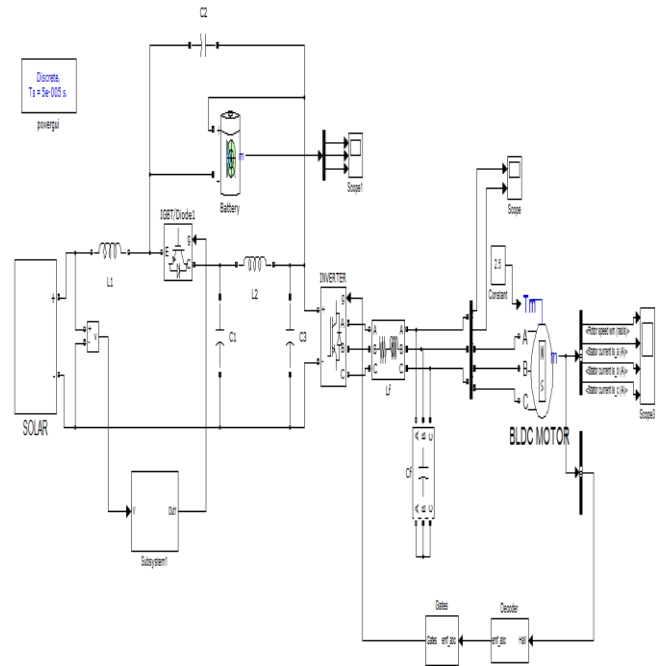

Fig. 7. Simulation circuit diagram

### A. Resultant waveform Input voltage and current

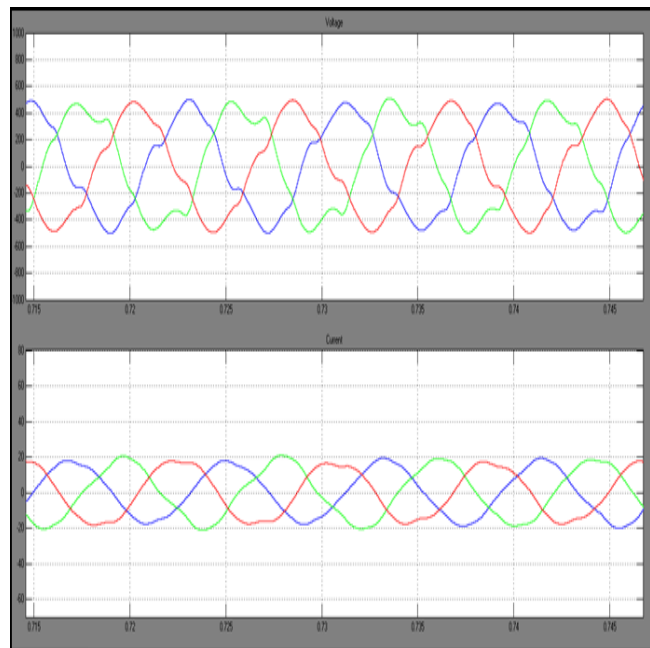

Fig. 8. Waveform of input voltage and current

### Output current

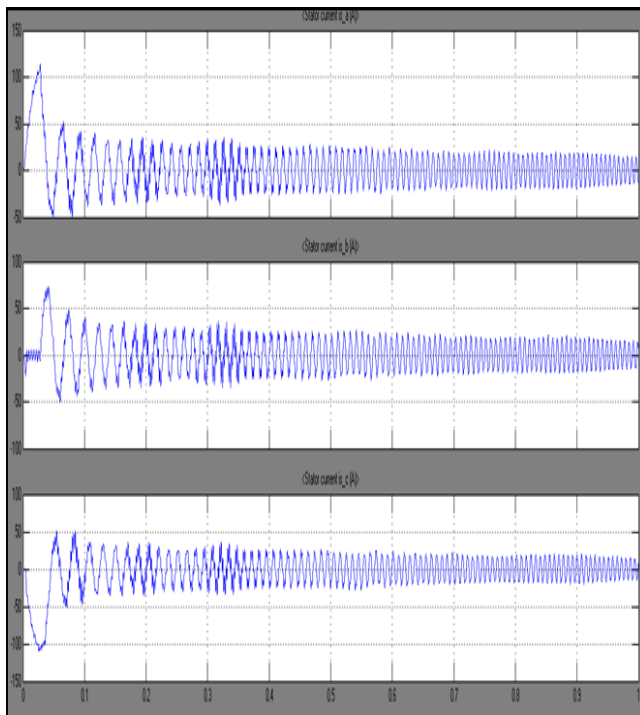

Fig. 9. waveform of output current

Motor speed

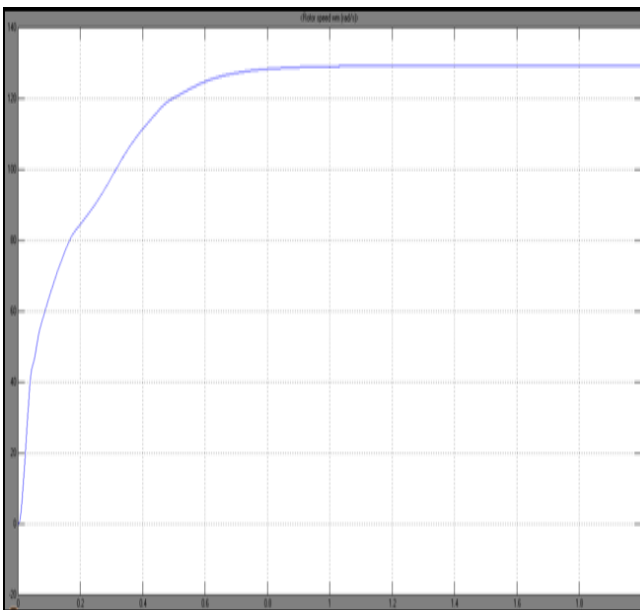

Fig. 10. Waveform of motor speed

## VI. CONCLUSION

The paper proposes ANFIS-based PV power generation system operating in standalone mode. The interface stage between the generation source and the load is accomplished by a qZSI. The shoot through duty ratio is controlled using ANFIS to harness the maximum available power from the

PV system. The load side voltage and frequency is regulated by controlling the modulation index of the interface of the qZSI. Thus simultaneous control of shoot through duty ratio and the modulation index ensure the control objectives achieved. Simulation and experimental results are provided to verify the proposed control approach. This results confirm the effectiveness of the controller, exhibiting good reference-tracking and disturbance rejection characteristics.

## REFERENCES

- [1] Yuan Li, Shuai Jiang, Jorge G. Cintron-Rivera, and Fang Zheng Peng “Modeling and Control of Quasi-Z-Source Inverter for Distributed Generation Applications”, IEEE Trans Ind. Electron., Vol. 60, no.4, Apr.2013
- [2] Dr.T.Govindaraj, and V.Purushothaman, “Simulation Modeling of Inverter Controlled BLDC Drive Using Four Switch,” International Journal of Advanced and Innovative Research.ISSN: 2278-7844, Dec- 2012, pp 554-559
- [3] S. Busquets-Monge, J. Rocabert, P. Rodríguez, S. Alepuz, and J. Bordonau, “Multilevel diode-clamped converter for photovoltaic generators with independent voltage control of each solar array,” IEEE Trans Ind. Electron., vol. 55, no. 7, pp. 2713–2723, Jul. 2008
- [4] A. M. S. Aldobhani and R. John, “Maximum power point tracking of PV system using ANFIS prediction and fuzzy logic tracking,” in Proc. Int. Multiconf. Engineeris and Computer Scientists (IMECS), Hong Kong, Mar. 19–21, 2008, vol. II, CD-ROM.
- [5] Y. Huang, M. Shen, F. Z. Peng, and J. Wang, “Z-source inverter for residential photovoltaic systems,” IEEE Trans. Power Electron., vol.21, no. 6, pp. 1776–1782, Nov. 2006.
- [6]L. Quan and P. Wolfs, “A review of the single phase photovoltaic module integrated converter topologies with three dc link configurations,” IEEE Trans. Power Electron., vol. 23, no. 3, pp. 1320–1333, May 2008.
- [7] B. M. T. Ho and S.-H. Cheng, “An integrated inverter with maximum power tracking for grid-connected PV systems,” IEEE Trans. Power Electron., vol. 20, no. 4, pp. 953–962, Jul. 2005.
- [8] B. Yang, L. Wuhua, Y. Zhao, and H. Xianging, “Design and analysis of a grid-connected photovoltaic power system,” IEEE Trans. Power Electron., vol. 25, no. 4, pp. 992–1000, Apr. 2010.
- [9] F. Ansari, S. Chatterjee, and A. Iqbal, “Fuzzy logic control scheme for solar photo voltaic system for maximum power point tracker,” Int. J. Sustain. Energy, vol. 29, no. 4, pp. 245–255, Apr. 2010.
- [10] R.Krishnan, “Electric Motor Drives Modeling, Analysis, and Control”, Pearson Education Edition, 2004.
- [11]Govindaraj Thangavel, Debashis Chatterjee, and Ashoke K. Ganguli,” Design, Development and Finite Element Magnetic Analysis of an Axial Flux PMLM,” International Journal of Engineering and Technology, Vol.2 (2), 169-175 , 2010
- [12] Govindaraj Thangavel, Ashoke K. Ganguli and Debashis Chatterjee,”Dynamic modeling of direct drive axial flux PMLM using FEM analysis” International journal of Elixir Electrical Engineering Vol.45 pp 8018- 8022, April 2012
- [13] G. Thangavel and A. K Ganguli,”Dynamic Modeling of Directive Drive Axial Flux PM Linear Oscillatory Machine Prototype Using FE Magnetic Analysis”, Iranian Journal of Electrical and Computer Engineering, Vol. 10, No. 2, Summer-Fall 2011
- [14] Govindaraj Thangavel, Debashis Chatterjee, and Ashoke K. Ganguli,”Design, Development and Control of an Axial Flux Permanent Magnet Linear Oscillating Motor using FE Magnetic Analysis Simulation Models,” Int. Journal of Electrical and Electronics Engineering, Oradea, Romania, October 2010
- [15] Govindaraj Thangavel, Debashis Chatterjee, and Ashoke K. Ganguli,”FEA based Axial Flux permanent Magnet Linear Oscillating Motor,” International Journal THE ANNALS OF "DUNAREA DE JOS" UNIVERSITY OF GALATI F ASCICLE



III. ELECTROTECHNICS, ELECTRONICS, AUTOMATIC CONTROL, INFORMATICS, July 2010

[16] Govindaraj Thangavel, Debashis Chatterjee, and Ashoke K. Ganguli, "FEA Simulation Models based Development and Control of An Axial Flux PMLM," International Journal of Modelling and Simulation of Systems, Vol.1, Iss.1, pp.74-80, 2010

### BIOGRAPHY



**Dr. Govindaraj Thangavel** born in Tiruppur, India, in 1964. He received the B.E. degree from Coimbatore Institute of Technology, M.E. degree from PSG College of Technology and Ph.D. from Jadavpur University, Kolkata, India in 1987, 1993 and 2010 respectively. His Biography is included in Who's Who in Science and Engineering 2011-2012 (11th Edition). Scientific Award of Excellence 2011 from American Biographical Institute (ABI). Outstanding Scientist of The 21st century by International Biographical centre of Cambridge, England 2011.

Since July 2009 he has been Professor and Head of the Department of Electrical and Electronics Engineering, Muthayammal Engineering College affiliated to Anna University, Chennai, India. His Current research interests includes Permanent magnet machines, Axial flux Linear oscillating Motor, Advanced Embedded power electronics controllers, finite element analysis of special electrical machines, Power system Engineering and Intelligent controllers. He is a Fellow of Institution of Engineers India (FIE) and Chartered Engineer (India). Senior Member of International Association of Computer Science and Information Technology (IACSIT). Member of International Association of Engineers (IAENG), Life Member of Indian Society for Technical Education (MISTE). Ph.D. Recognized Research Supervisor for Anna University and Satyabama University Chennai Editorial Board Member for journals like International Journal of Computer and Electrical Engineering, International Journal of Engineering and Technology, International Journal of Engineering and Advanced Technology (IJEAT), International Journal Peer Reviewer for Taylor & Francis International Journal "Electrical Power Components & System" United Kingdom, Journal of Electrical and Electronics Engineering Research, Journal of Engineering and Technology Research (JETR), International Journal of the Physical Sciences, Association for the Advancement of Modelling and Simulation Techniques in Enterprises, International Journal of Engineering & Computer Science (IJECS), Scientific Research and Essays, Journal of Engineering and Computer Innovation, E3 Journal of Energy Oil and Gas Research, World Academy of Science, Engineering and

Technology, Journal of Electrical and Control Engineering (JECE), Applied Computational Electromagnetics Society etc.. He has published 132 research papers in International/National Conferences and Journals. Organized 40 National / International Conferences/Seminars/Workshops. Received Best paper award for ICEESPEEE 09 conference paper. Coordinator for AICTE Sponsored SDP on Soft Computing Techniques In Advanced Special Electric Drives, 2011. Coordinator for AICTE Sponsored National Seminar on Computational Intelligence Techniques in Green Energy, 2011. Chief Coordinator and Investigator for AICTE sponsored MODROBS - Modernization of Electrical Machines Laboratory. Coordinator for AICTE Sponsored International Seminar on "Power Quality Issues in Renewable Energy Sources and Hybrid Generating System", July 2013.