



# Smart System for Hazardous Event Detection and Evaluation in Mining Industries

Praveen Kulkarni<sup>1</sup>, Dr. V.G. Sangam<sup>2</sup>

M. Tech Student, Electronics and Instrumentation Engg, Dayananda Sagar College of Engineering, Bengaluru, India<sup>1</sup>

Electronics and Instrumentation Engineering, Dayananda Sagar College of Engineering, Bengaluru, India<sup>2</sup>

**Abstract:** Underground Mine Safety Monitoring System can achieve a variety of safety factors of production, and underground environment (such as gas, temperature, Roof Fall etc) for monitoring mine production, safety management to provide a good basis for decision making. A smart system is being proposed here, that is able to detect and evaluate air quality (Toxic gases) and Hazardous events in the underground mining industry. It gives a new method of analysing hazardous events happening in the mining such as Methane, Propane, Butane, Benzene, Carbon monoxide and other toxic gases. This paper which gives detail description of a system to evaluate the concentration of hazardous gases. This system is developed with ARM processor apart from this the proposed system will indicate the helmet position on the person as well as any external input on the helmet and . To measure these events suitable sensors will be used and interfaced to ARM processor and ZigBee. The system prototype developed has many advantage that makes it convenient to work in harsh environment of underground mine, monitoring the concentration of deadly gases in its atmosphere along with temperature, Fire, Pressure, IR sensor.

**Keywords:** Smart System, ARM Processor, ZigBee, IR sensor.

## I. INTRODUCTION

Mining ranks among the more dangerous (hazardous) of human profession or job in the world as far as Safety and health of worker is concerned. Hundreds of people die every year in the mines due to lack of safety measures[2]. The miners who work in mining are always a risk of death. The Environmental inside the mine is very difficult apart from risk of losing life, when working with noisy equipment's, being aware of one's surrounding. In emergency wireless sensor (ZigBee) Communication may become vital role for survival, during the disaster such as Roof-falls, fire, and emission of hazardous gases, the conventional wireless communication is composed of sensors which are deployed across a mining area[6].

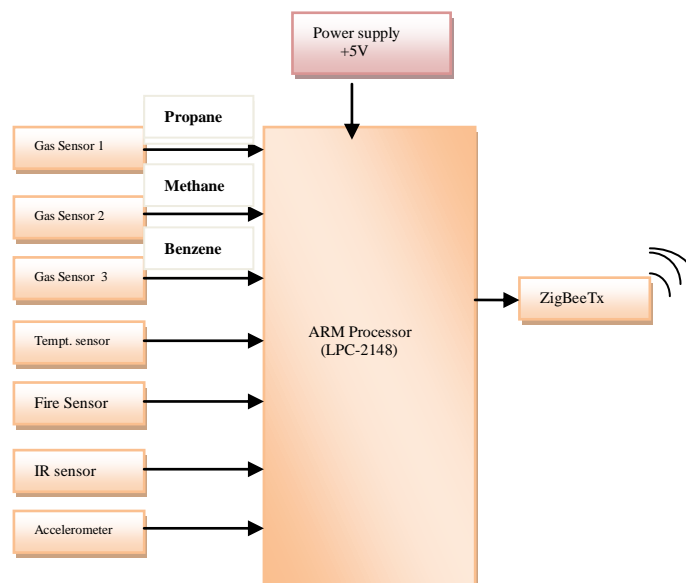

Figure 1: Underground sensor unit.

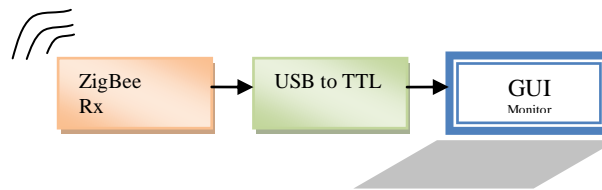

Figure 2: Monitoring Unit Section

The proposed system consist of two section one is underground section (Figure 1) and another is monitoring section (Figure 2) which as shown in figures. In underground section with smart system is modified using mining helmet with a sensor which will sense the environment conditions such as Fire, Temperature and Hazardous gases concentration level etc..., and this information is send to ARM Processor(LPC-2148).The ARM processor which as connection of ZigBee module which transfer a data to the monitoring unit. This system needs to transmit data within one second. In monitoring section ZigBee receiver will receives data and displays in the GUI(Graphical Unit Interface).

## II. METHODOLOGY

Solving the problem of miners removing their safety equipment (Gears) will be the challenge. Taking the other consideration of any new safety equipment or gears that are not lightweight and non-distractive will just be removed like all other safety gears. Helmet is the only safety gear, miners tend to keep on; this where new equipment are added on to. Few sensors are used; An Accelerometer, Air Quality (determining the hazardous gases), Temperature, Fire and IR sensor. These will be either to detect if a miner has an experienced a bump on the head or removed his helmet (Using Accelerometer we can determine) and surrounding area quality. These sensors are connecting to ZigBee module. The whole system is analysing throughout the design process in order to keep the power consumption to a minimum as the system is running in order to keep battery power. The system consists of Helmet remove sensor, fire sensor, Temperature sensor, Position sensor, air quality sensor, Data processing unit and wireless Transmission and alerting unit. Figure 1 represents the block diagram of the smart system for mining safety.

### A. Gas Sensor(Quality of Air)

In mine, gases are released during mining operations. It will be observed that return air is depleted in oxygen content and contaminated by mine particular matter. Impurities comes from exhalation by men, blasting and underground fires Burning of lights[1], Bacterial action and gases given off from layers of ground. Air pollution from coal or other mines is mainly due to emissions of particular matter and gases include methane (CH<sub>4</sub>), propane, benzene and oxides of Hydrogen, carbon monoxide (CO) etc..., From Different studies on these gases when the human comes in contact chemicals/ pollutants could have the adverse effect on their health. These unbalanced ratios of air pollutant gases which suspend particulate matter, Increases respiratory diseases such as asthma, Heart disease blurred vision, chronic bronchitis and cardiovascular problems. In this article, we have measured the propane and benzene. For detection and evaluation of the gas concentration level, we used electrochemical sensor because of its accuracy and low power consumption's in the development of air quality detectors with this we used LED because crossing of threshold concentration level of the gas the LED will blink to indicate the higher concentration of gas.

### B. Helmet Removal sensor (IR sensor)

For detecting the removal of the helmet a few different approaches will be considering. For this study, we used the IR beam based helmet remove sensor technique is considered better among the other available technique such as a switch, Analogue Distance sensor, Ultrasonic distance sensor and digital distance sensor.

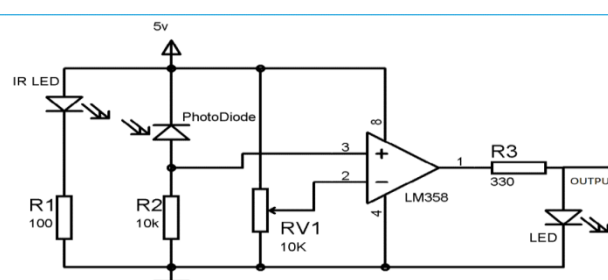

Figure 3: IR Sensor Circuit Diagram (Courtesy Google image)



The IR beam can be designed to use the low amount of power and its cost is less. an off-the-shelf IR digital detector is using for this application. The IR sensor was designed to send a constant signal from the one side of the helmet to another side with the circuit.

C. Temperature sensor(LM-35)

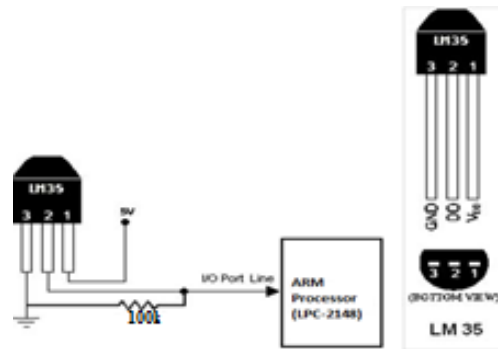

Figure 4: Temperature sensor Circuit

In the proposed system thermistor(LM35) is used as temperature sensor. The word thermistor is an acronym for thermal sensitive resistor. i.e., a temperature sensitive resistor. It is used to detect very small changes in temperature. The variation in temperature is reflected through appreciable variation of the resistance of the device. Here it may be noted that NTC thermistor has a resistance of about 10kΩ and 100kΩ at -50 C to 150 C Respectively. It is connected to P0.28 to LPC2148.

D. Accelerometer(ADXL 335)

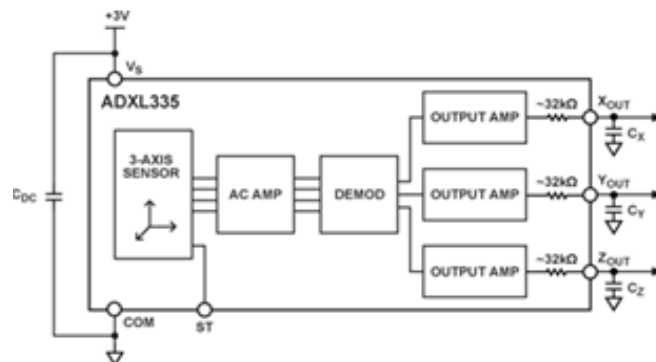

Figure 5: accelerometer sensor (Courtesy: Google Image)

ADXL 335 is a thin, low power consumption ,small and complete 3-axis with signal conditioned voltage outputs. The product measures acceleration with a minimum full-scale range of ±3g. It can measure static[4] acceleration of gravity in tilting applications , as well as dynamic acceleration resulting from motion, shock or vibration

In order to conclude that a bump is actually dangerous, the bump need to exceed a certain threshold for a certain amount of time. According to the Federal motor Vehicle safety standard 208(FMVSS 208) a Head Injury Criteria (HIC) should not exceed more than 1000

$$HIC = \left[ (t_2 - t_1) \left[ \frac{1}{t_2 - t_1} \int_{t_1}^{t_2} a(t) dt \right]^{2.5} \right]_{\max} \quad (1)$$

The variable  $t_1$  is starting time,  $t_2$  is ending time,  $a(t)$  is the acceleration over time. An accelerometer was needed to measure the acceleration of the system. The acceleration is needed to be able to measure at least 80g in 3-axes. ADXL35 accelerometer satisfying the specifications. There are few limitations using the HIC equation. The time interval  $t_2$  and  $t_1$  should be limited to the maximum of only 36ms .the time limitations is to limit the equation to impact and not sustained acceleration And the accelerometer is placed on the helmet itself and not on the plastic harness



holding the head. The user selects the bandwidth of the accelerometer using the  $C_X$ ,  $C_Y$ , and  $C_Z$  capacitors at the  $X_{OUT}$ ,  $Y_{OUT}$ , and  $Z_{OUT}$  pins. Bandwidths can be selected to suit the application, with a range of 0.5 Hz to 1600 Hz for X and Y axes, and a range of 0.5 Hz to 550 Hz for the Z axis.

#### E. Wireless Transmission(ZigBee)

ZigBee/ IEEE 802.15.4 Technology is used to solve a wide range of issues, the automation of technologies processes a cleaver house system. The ZigBee module has 1mW output power and produces declares an operating radius up to 1.2km in open air and 10-100m in indoors. It currently operates in the 2.4GHz band at a maximum data rate of 250kbps. The transceiver has an on-chip wire antenna and it operates at a frequency of 2.4GHz. the data is received from the ARM Controller is organized based on the ZigBee protocol standard and then modulated. The specification supports data rates 250kbs at a range up to 100m. The Zigbee Technology is slower than 802.11b(11 Mbps)and Bluetooth(1Mbps) but it consumes significantly less power[5]. Here a pair of ZigBee modules is used one to transmit the data from underground section and another to receive the data at monitoring section.

#### F. Data Processing Unit(LPC-2148)

The ARM Controller(LPC-2148) is a member of Advance RISC(Reduced Instruction Set Computer) machines(ARM) family of general purpose 32-bit microprocessor, which offer performance very low power consumption[7]. The arm Architecture is based on reduced instruction set computer principles and the introduction set and related decode mechanism are much simpler than those of microprogrammed Complex (CISC) this simplicity results in a high instruction throughput and poignant real time interrupt response from a[8] small and cost effective chip, pipelining is employed so that all parts of the processing and memory systems can operate continuously, typically, while a instruction being execute, its successor is being decoded. LPC-2148 ARM processor as the main processor in conjunction with ZigBee module as the wireless communication terminal, keeping with open Hardware design. The sensors and ZigBee module would be connected to the LPC-2148 ARM Processor. The LPC-2148 would be then be used to create the user interface for the user to examine the data that has been logged. Two problems turned up; the first being power consumption and second interfacing with the LPC-2148. The power consumption was a problem as the system would be running off a battery,, even though the LPC-2148 uses very little power it is much more than what is used by the ZigBee module. It has an adequate amount of processing power and a built in electrically erasable programmable read-only memory. Any other additional processing units would use more space and consume additional unit.

### III.RESULT AND DISCUSSION

The Critical levels of the hazardous such as Propane, Benzene, Methane is the mines industry has been indicated through alerting unit. The helmet removal was done successfully with an off-the-shelf IR object sensor. The IR sensor designed from the principle is a working device. It has to discover, after the system is integrate, that the Transmitted IR signals reflects off the Human head and keep reflecting off the helmet's surface until it reached the receiver. The accelerometer was accurately calibrated more accurately which it is used to detect the position of miner along with this pressure sensor is there whenever any things hits on him, miner may go unconscious. The system is measured axes of the accelerometer one after the other, as the ZigBee module only contains one ADC with different ports connected to the ADC through port switching. And Gas sensor is used to detect hazardous gases and after crossing the threshold level it will indicate Red LED light.



Figure 6: Result obtained at monitoring unit

**IV. CONCLUSION AND FUTURE WORK**

A smart system in underground mining was developed that is able to detect three types of hazardous events such as danger level of hazardous of experiment Methane, Propane and Benzene Gas were used to test. Miner helmet removing, and collision or impact (miner are stuck by an object). The hazardous event were classified as a miner removing the mining helmet off their head. An off-shelf IR sensor was then used to successfully determine when the helmet is on the miners head. Another hazardous event is defined as an event where miners stuck by an object against the head with force exceeding value of 1000 on HIC. An accelerometer with pressure sensor was used to measure to measure the acceleration of the head and HIC was calculated in software. The layout which successfully done to calibrate the accelerometer. Adding external ZigBee Antenna would extend the range or improve the signal strength in order to allow for more human interference. The processing speed of the system can be improved to allow for more accurate accelerometer measurement. The IR sensor can be improved to work within a helmet by not triggering because of reflections. This can be improved by adding stationary nodes that are programmed to only bounce any signal that is received. The system can be improved by adding more measuring devices to check the miner's blood pressure and heart rate. Gas concentration can be measured as well.

**REFERENCES**

- [1]. C. J. Behr, A. Kumar and G.P. Hancke "A Smart Helmet for Air Quality and Hazardous Event Detection for the Mining Industry," IEEE World Congress on Computer Science and Information Engineering 978-1-4673—8075-1/16(2016)
- [2]B. Silva, A. Kumar and G. P. Hancke, "Experimental Link Quality Characterization of Wireless Sensor Networks for Underground Monitoring," The Journal of The Southern African Institute of Mining and Metallurgy, vol. 107, pp. 531-538, Aug. 2011.
- [3] SnigdhaKundu, Asim Kumar Pal, "Estimation of air quality in the opencast mine of Jharia Coal field, India," The Journal of Mining and Metallurgy, pp. 209-216, July 2014.
- [4] VaibhavPandit , Prof. U. A. Rane, "Coal Mine Monitoring Using ARM7 and ZigBee," Journal of Networks, vol. 7, no. 7, pp. 1054–1062, Jul. 2012.
- [5] C. Qiang, S. Ji-ping, Z. Zhe and Z. Fan, "ZigBee Based Intelligent Helmet for Coal Miners," IEEE World Congress on Computer Science and Information Engineering (WRI 2009), 31 Mar. -2 April 2009, vol. 3, pp. 433–435, 2009.
- [6] H. Hongjiang and W. Shuangyou, "The application of ARM and ZigBee technology wireless networks in monitoring mine safety system," IEEE International Colloquium on Computing, Communication, Control, and Management (ISECS 2008), 3-4 Aug. 2008, Guangzhou, pp. 430–433, 2008.
- [7] R. S. Nutter, "Hazard evaluation methodology for computer-controlled mine monitoring/control systems," IEEE Trans. on Industry Applications, vol. IA-19, no. 3, pp. 445-449, May/June 1983.
- [8] R. S. Nutter, "A distributed microprocessor monitoring and control system for coal mines," in Proc. 4th WVU Conf. on Coal Mine Electrotechnology, Aug. 2-4, 1978.