

The Intelligent Suitcase

Ms. Sneha Jainwar¹, Mr. B. HariKishore Rao², Ms. Khyati Varma³, Ms. Honey Tamrakar⁴

Electronics and Telecommunication Department, Bhilai Institute of Technology College, Durg, Swami Vivekananda
Technical University, Chhattisgarh, India^{1,3}

Mechatronics, Chhatrapati Shivaji Institute of Technology, Durg, Swami Vivekananda Technical University,
Chhattisgarh, India²

Electronics and Telecommunication Department, Shri Shankaracharya College of Engineering and Technology,
Bhilai, Chhattisgarh, India⁴

Abstract: In a generation where time is the greatest deciding factor, air travel is the most preferred means of transport. Air transport being the fastest means of transport is best suited for long distances travel within minimal time. Airports and airlines are the emerging global companies providing air services. With the added advantages of airlines and airports, travellers face the most common and annoying problem of luggage loss. The loss and mixing of luggage is the most awful experience faced by hundreds of passengers every day. Not much is done in this field to help out the passengers with the problems of suitcase/luggage mixing and loss. To help the travellers we have developed the concept of an intelligent suitcase. This intelligent suitcase is designed with the help of latest technology solving the problems of mixing and loss of suitcases at the airports. The suitcase works on the Bluetooth technology interfaced with a controlling unit, Gps/gsm modules, Rfid cards, ultrasonic sensors, power unit, load cell etc. The suitcase can be easily tracked for its location by the help of the gps technology and the Rfid cards help in the unique identification of the suitcase. It is controlled by the Smartphone of the passenger and the Bluetooth technology helps in digital locking, location tracking and identification along with many other specially designed features.

Keywords: Baggage, Bluetooth control, Gps tracking, Rfid Card, Digital Locking.

I. INTRODUCTION

Airlines provide air services for passengers and freight. Air transportation is preferred for its high speed, less time, more comfort etc. Airports and Airlines are the 21st century most widely growing sector. With the numerous advantages and comfort for the passengers, mixing and loss of luggage is the most common and annoying problem also faced by them. Baggages are generally mixed and lost and not much is done to help the frustrated passengers who have no way to track their bags. To solve the problem of mixing and loss we have developed an intelligent suitcase system. This system is digitally controlled by the person's phone through the Bluetooth technology with the features of digital locking, unique identification and location tracking.

Also the suitcase has inbuilt charging unit and weight measuring system for the comfort of the travellers. One more additional advantage of this intelligent suitcase is that you don't have to drag the suitcase from place A to B. The Bluetooth technology interfaced with the smart phone along with the ultrasonic sensors and driver motors helps the suitcase to follow the owner on its own and avoid obstacles on its path through the tracker and ultrasonic sensors and indicators. This intelligent suitcase is designed for the easy, safe and hassle free and comfortable travel.

II. BLOCK DIAGRAM

The block diagram showed below outlays the basic concept of the intelligent suitcase. The main controlling unit is Arduino Uno. The other components are Bluetooth module, Gps/Gsm module, load cell, motor drivers, power unit, rfid cards, ultrasonic sensors etc. A single chip with all the above modules/components embedded in it is inserted within the suitcase. The Figure below represents the block diagram of our project.

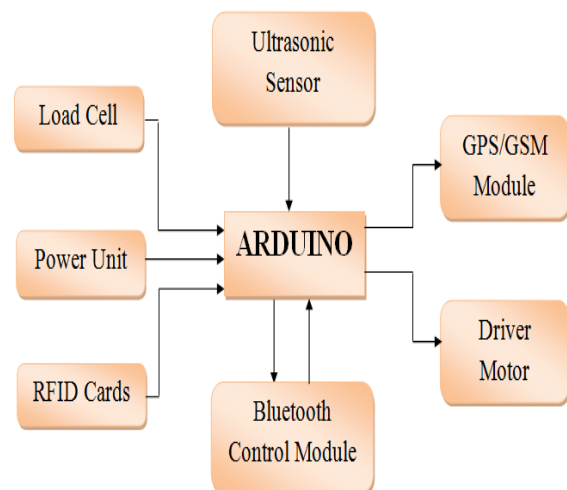

Fig. 1. Block diagram

III. TECHNICAL DESCRIPTION

A. ARDUINO UNO -

It is a single board microcontroller based on the Atmega328. It is an open source hardware- software used for development of electronic devices and its interfacing. Arduino uses SRAM memory with flash and EEPROM storage technology. It is a 14 pin device operating at 5volts supply.

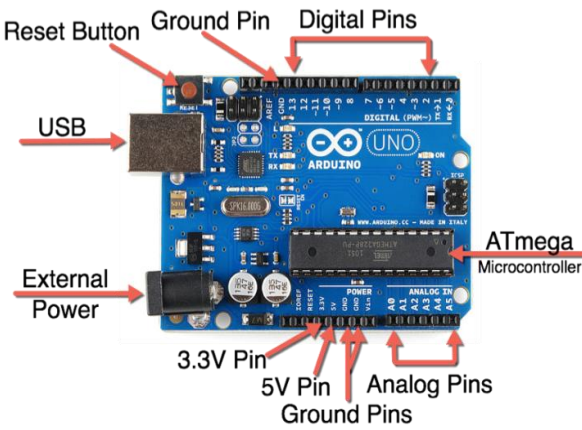

Fig. 2. Arduino Uno

B. BLUETOOTH MODULE :

A HC-06 wireless bluetooth transceiver rf main module serial for Arduino is used to transmit and receive serial data wirelessly over the phone. This module is used for establishing wireless Bluetooth connection between two devices.



Fig 3: Bluetooth Module

C. GSM/GPS MODULE :

Global positioning system is used for tracking the location of a device. It a satellite based navigation system used to track and tell the position /location of a device. GSM module is used for text messaging over a mobile data network. It is used along with gps module to text messages the location displayed by the gps module to the receiver.

D. DRIVER MOTOR :

L293D motor driver is used to drive the suitcase powered with arduino uno in conjunction.

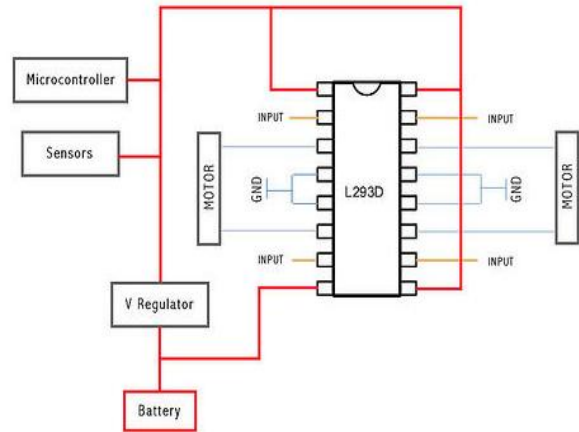

Fig. 4. Circuit for controlling motors with LM293D

E. RFID Cards :

Radio- frequency identification uses electromagnetic field to identify and track objects. RFID is method of Automatic Identification and Image Capture.

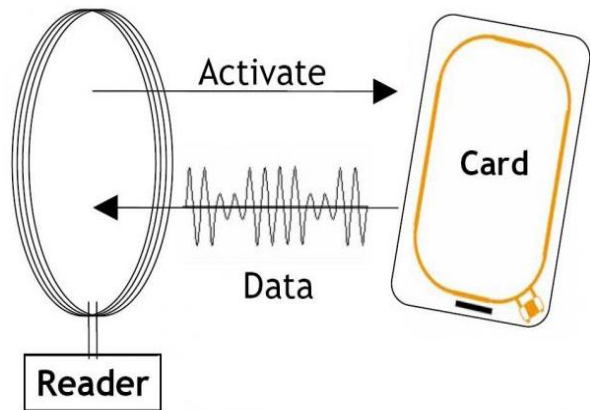

Fig. 5. Working Process of RFID Cards

F. LOAD CELL:

It is a type of transducer which converts applied force into electrical energy indicating weight of the object. The various types of load cells are hydraulic load cell, strain gauge load cell etc.

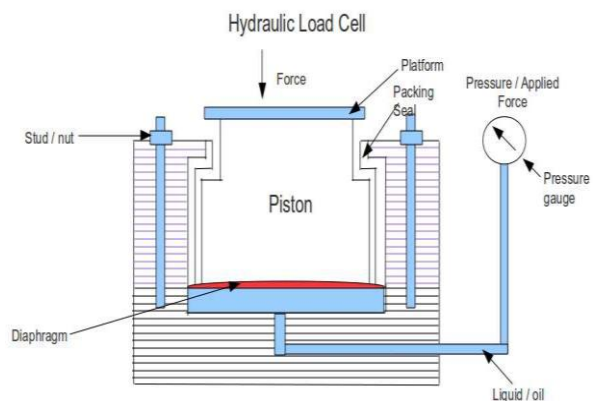

Fig. 6. Hydraulic Load cell

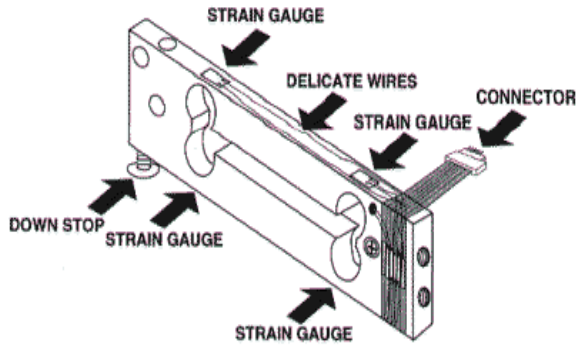

Fig. 7. Strain Gauge Load cell

G. ULTRASONIC SENSOR:

These sensors are based on the ultrasonic sound waves measurements which are above the human audible frequency range. Time of flight, Doppler effect and attenuation of sound waves are the basic principles of ultrasonic sensors.

IV.METHODOLOGY

The intelligent suitcase is designed to access serial data from the smart phone and output it to the arduino uno. The Bluetooth signal helps the suitcase to follow the smartphone. The ultrasonic sensor maps the path to be travelled and avoids obstacles. The suitcase is digitally locked through the Bluetooth and smart phone.

The gps module helps in tracking the location of the suitcase from anywhere in the world and the gsm modules sends the text message of the location to the owner's mobile phone. The unique rfid cards interfaced with phone helps in the easy identification of the suitcase/luggage removing the possibility of mixing of bags.

The inbuilt power unit helps to charge an electronic device through the battery stored. The load cell used helps to display the weight of the bag which is proportional to the force applied by the suitcase on the load cell. This technology when applied to the suitcase can make travelling more convenient and secure.



Fig. 8. Interfacing arrangement

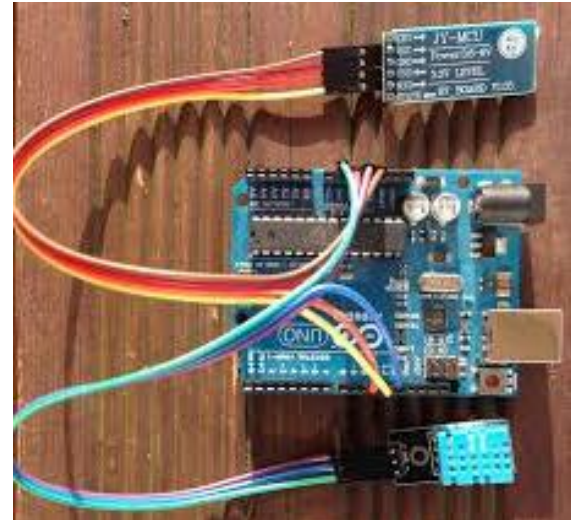

Fig. 9 Arduino with Bluetooth module

V. ADVANTAGES

1. Digital locking System through smart phone for security against theft.
2. GPS tracking system along with the location notifications.
3. It can be used to charge any electronic device.
4. Weight of the suitcase can be easily displayed.
5. Unique id for each suitcase to avoid mixing.
6. The suitcase is designed to follow the owner on its own without the need of dragging it.

VI.RESULTS AND CONCLUSION

This suitcase when designed will solve the most common problems of luggage loss faced by the passengers at the airports. The Gps tracking, Bluetooth controlling will help the passengers to have safe and secure journey without any fear of luggage loss. This prototype when developed for the general public will be of great benefit and use to them.



Fig. 10 Designed Suitcase

REFERENCES

- [1] Air Transport: Advantages and Disadvantages from www.economicdiscussion.net
- [2] Here's-what-to-do-when-an-airline-loses-your-luggage from www.businessinsider.in
- [3] www.Bluesmart.com

BIOGRAPHIES

Ms. Sneha Jainwar pursuing Engineering in Electronics and Telecommunication department from Bhilai Institute of Technology Durg, Chhattisgarh, India. I had published paper in International Journal.



Mr. B. Harikishore Rao pursued Engineering in Mecatronics department from Chhatrapati Shivaji Institute of Technology Durg, Chhattisgarh, India. I had published paper in International Journal.



Ms. Khyati Varma pursuing Engineering in Electronics and Telecommunication department from Bhilai Institute of Technology Durg, Chhattisgarh, India. I had published paper in International Journal



Ms. Honey Tamrakar pursuing Engineering in Electronics and Telecommunication department from Shri Shankaracharya college of Engineering and technology Durg, Chhattisgarh, India. I had published paper in International Journal