

# Comparison of Conventional PFC Boost Converter and Bridgeless PFC Boost Converter

**Isarar Ahamad<sup>1</sup>, Mohammad Asim<sup>2</sup>, Prabhat Ranjan Sarkar<sup>3</sup>, Faizan Arif Khan<sup>4</sup>**

Assistant Professor, Electrical Engineering Department, Intergral University, Lucknow, India<sup>1, 2, 3, 4</sup>

**Abstract:** The use of electronic equipment has increased in last few years. AC rectification is a very inefficient process, resulting in waveform distortion of the current which is drawn from the source. This produces a large spectrum of harmonic signals that may interfere with other equipment. In input rectifier bridge the conventional boost PFC suffers from the high conduction loss. By using bridgeless boost converter higher efficiency can be achieved. The voltage sensing, current sensing and EMI noise has issues in this new circuit. In this paper at different voltage level by changing the duty ratio the affect of efficiency is studied for both conventional and bridgeless boost converter.

**Keywords:** Power factor Correction (PFC), Boost Converter, Duty ratio, MATLAB/SIMULINK.

## I. INTRODUCTION

Power factor is defined as a measure of how a load draws power from the AC source. Leading or lagging PF causes transmission and distribution losses and also the poor utilization of electrical power. A high power factor means better utilization of electrical power, while a low power factor represents poor utilization of electrical power [1]. Due to leading or lagging power factor the electrical energy is to be transferred back and forth between the load and the source and only a part of this electrical energy is utilized for real work. The presence of nonlinear loads produce voltage fluctuations, harmonic currents and an imbalance in network system which results into low power factor operation of the power system. The basic block in many power electronic converters are uncontrolled diode bridge rectifiers with capacitive filter [2]. Due to the nonlinear nature of bridge rectifiers, non-sinusoidal current is drawn from the utility and harmonics are injected into the utility lines. The bridge rectifiers contribute to high THD, low PF, and low efficiency to the power system. These harmonic currents cause several problems such as voltage distortion, heating, noises etc. which results in reduced efficiency of the power system. Due to this fact, there is a need for power supplies that draw current with low harmonic content and also have power factor close to unity [3]. In this paper, a systematic comparison of the bridgeless PFC boosts converters and conventional Boost converters that have received the most attention [4]. Performance comparison between the conventional PFC boost rectifier and a representative member of the bridgeless PFC boost rectifier family is performed. Loss analysis and experimental efficiency evaluation for both continuous- conduction mode (CCM) and discontinuous-conduction mode (DCM)/CCM boundary operations are provided for both conventional and bridgeless PFC Boost converters [5].

## II. CONVENTIONAL PFC BOOST CONVERTER

A. The conventional input stage for single phase power supplies operates by rectifying the ac line voltage and

filtering with large electrolytic capacitors. This process results in a distorted input current waveform with large harmonic content [6]. As a result, the power factor becomes very poor around .The reduction of input current harmonics and operation at high power factor (close to unity) is important requirements for power supplies [7]. The conventional boost topology is the most widely used topology for PFC applications. It consists of a front-end full-bridge diode rectifier followed by the boost converter. The technique usually employed Page Layout to correct power factor of single-phase power supplies consists of a front-end full-bridge diode rectifier followed by a boost converter, as shown in fig 1. This approach is good for a low to medium power range. As the power level increases, the diode bridge becomes an important part of the application and it is necessary to deal with the problem of heat dissipation in limited surface area [8]. The dissipated power is important from a efficiency point of view.

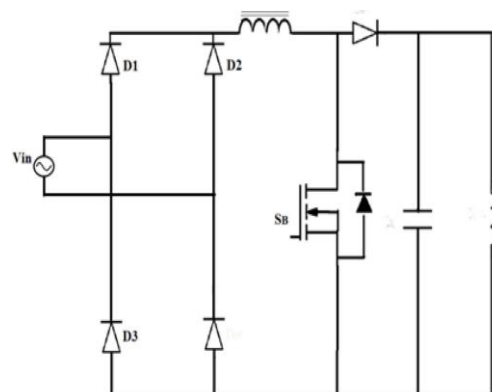

Fig.1: Conventional PFC Boost Converter

## III. BRIDGELESS PFC BOOST CONVERTER

The bridgeless configuration topology avoids the need for the rectifier input bridge yet maintains the classic boost topology [9]. This is easily done by making use of the intrinsic body diode connected between drain and source of Power MOS switches.

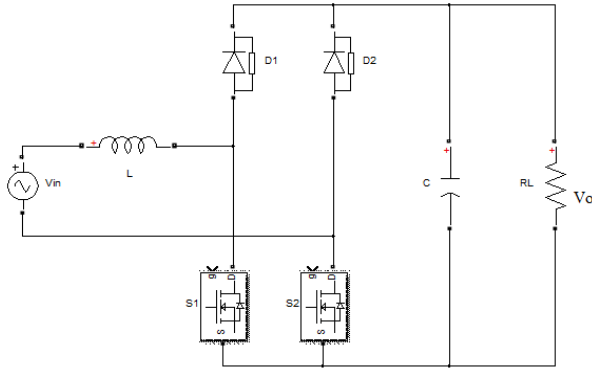

Fig.2: Basic Bridgeless PFC Boost Converter

The circuit shown from a functional point of view is similar to the common boost converter. In the traditional topology current flows through two of the bridge diodes in series [10]. In the bridgeless PFC configuration, current flows through only one diode with the Power MOS providing the return path. To analyse the circuit operation, it is necessary to separate it into two sections. The first section operates as the boost stage and the second section operates as the return path for the AC input signal [11].

#### IV. SIMULATION ANALYSIS FOR CONVENTIONAL PFC BOOST CONVERTER

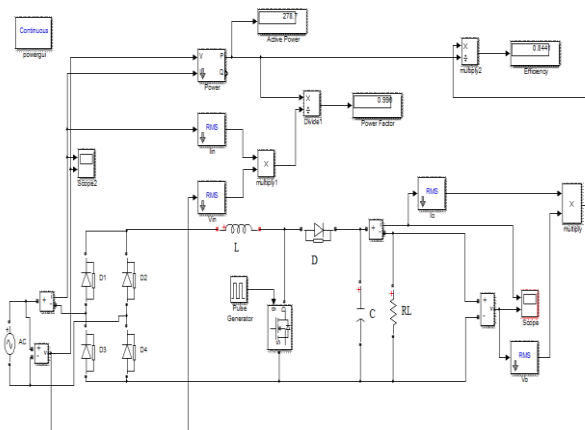

Fig.3: Matlab/Simulink model of Conventional PFC Boost Converter

##### A. Result:

The result of Simulink model of basic conventional PFC Boost Converter has been given below.

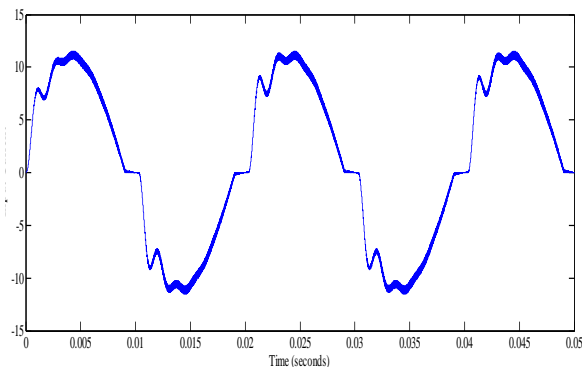

Fig.4: Input Current

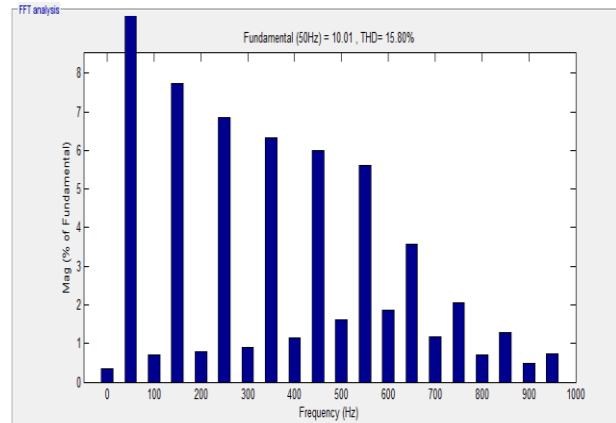

Fig.5: FFT Analysis

##### (a) Measured THD, PF and Output Power of the Conventional PFC Boost Converter at 24 Volt

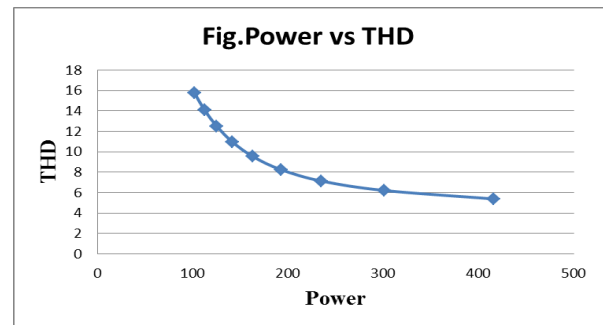

Fig.6: Power vs. THD Curve

##### (a) Simulation result of Conventional PFC Boost Converter:

The model is simulated for 0.05 second. Power Factor is found 0.9618, THD is 15.80%, Active Power 117 watt and efficiency is 0.8687.

#### V. SIMULATION ANALYSIS FOR BRIDGELESS PFC BOOST CONVERTER

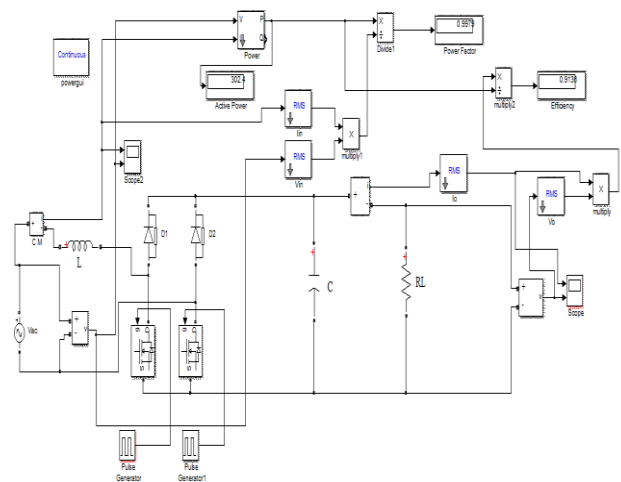

Fig.7: Matlab/Simulink model of Bridgeless PFC Boost Converter

**B. Result:**

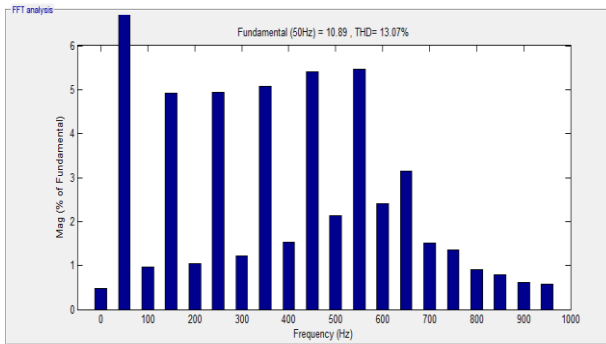

Fig.8: FFT Analysis

**(a) Measured THD, PF and Output Power of the Conventional PFC Boost Converter at 24 Volt**

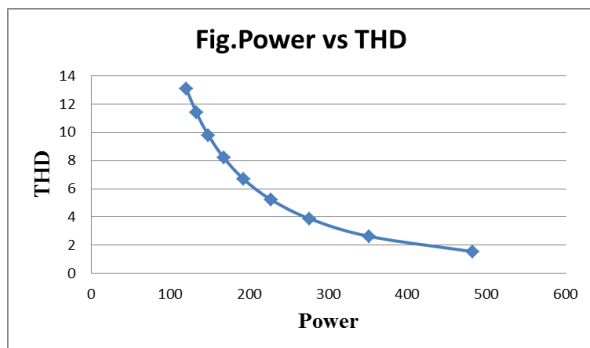

Fig.9: Power vs. THD Curve

**Simulink result of Bridgeless PFC Boost Converter:**

The model is simulated for 0.05 second. Power Factor is found 0.9656, THD is 13.07%, Active Power 127.3 watt and efficiency is 0.9454.

**VI. CONCLUSION**

Both single Phase Bridgeless PFC Boost converter and conventional PFC Boost converter are modelled and simulated. The results show that bridgeless PFC Boost Converter not only improves the power factor in comparison to conventional PFC Boost converter but it also seen that as duty ratio changes the efficiency of the system changes as the losses of the system varies . Losses include switching losses and conduction losses which depend upon switching frequency and duty ratio. The switching loss is based on the turn-on loss due to the effective capacitance of the MOSFET.

**REFERENCES**

[1] Mohammed Asim, Heena Parveen , Dr. M. A. Mallick , Ambreen Siddiqui, "Performance Evaluation Of Pfc Boost Converters", International Journal Of Innovative Research In Electrical, Electronics, Instrumentation And Control Engineering, Vol. 3, Issue 11, November 2015, pp 107-110

[2] Heena Parveen, Mohammed Asim, , Isarar Ahamad, "Efficiency Analysis of Bridgeless PFC Boost Converter" International journal for scientific research and development, vol. 04, issue 01, 2016.

[3] Sridevi J., "A New Active Power Factor Correction Controller using Boost Converter." Research Journal of Engineering Sciences, vol. Vol. 2, no. 8, pp. 2278 – 9472, 7-11, August (2013).

[4] E. E. EL-Kholy, S.A.Mahmoud\* and S.S.Shokralla H.Z.Azazi, "Review of Passive and Active Circuits for PowerFactor Correction in Single Phase, Low Power Ac-Dc converter," in 14th International Middle East Power Systems Conference (MEPCON'10), Cairo University, Egypt, December 2010, pp. 216-224.

[5] Ch.M.Lakshmi P.Vijay Prasuna J.V.G.Rama Rao, "Improvement in Power factor & THD using Dual Boost Converter," International Journal Of Engineering, vol. 2, no. 4, pp. 2368-2376, July-August 2012.

[6] Supratim Basu And Math.H.J. Bollen, "A Novel Common Power Factor Correction Scheme For Homes and Offices," IEEE Transactions on Power Delivery, vol. 20, no. 3, pp. 2257-2263, July 2005

[7] M.S. Jamil asghar, Power Electronics, 1st ed. New Delhi, India: Prentice Hall of India(PHI), 2005.

[8] Dr.J.A.Makwana S.B.Mehta, "Power factor Improvement of SMPS using PFC," International Journal of Application or Onnovation in Engineering & Management(IJAEM), vol. 3, no. 4, pp. 299-305, April 2014.

[9] Gerry Moschopoulos and Praveen Jain, "Single Phase Single Stage Power Factor Corrected Converter Topologies," IEEE Transactions on Industrial Electronics, vol. 52, no. 1, pp. 23-35, February 2005.

[10] Prabhat Ranjan Sarkar, Faizan Arif, Isarar Ahamad, "PERFORMANCE ENHANCEMENT OF MULTILEVEL INVERTER IN PV SYSTEM WITH NEW TOPOLOGY" International Journal of Advance Engineering and Research Development Volume 2, pp 301-306, January -2015.

[11] X. Yang, H. Wang, X. Yan, H. Lei and H. Guan, "Theoretic analysis and experimental study of a novel bridgeless partial active PFC ," in: proc. ICEMS, 2008, pp. 1179-1184.