

Simulation and Analysis of H-bridge Cascade Multi level Inverter Fed Induction Motor Drive for Industrial Applications

Jyoti verma¹, Manish Shah²

M Tech Scholar, Electrical and Electronics Engineering, VITS, Indore, India¹

Assistant Professor, Electrical and Electronics Engineering, VITS, Indore, India²

Abstract: Electrical drive using Induction motor draws heavy current during starting condition. The handling of large drives with variable speed is not possible with ordinary conventional inverter so the Multi level inverters are the best choice among available. The paper presents MLI with H-Bridge cascade system for industrial application. The present work is simulated with 7 and 9 level inverters and compares their results.

Keywords: MLI, Cascade, H-Bridge, Modulation index, Carrier Frequency.

I. INTRODUCTION

The electrical drive system has been an integral part of any industry. The performance enhancement for variable speed drive system is now possible with solid state controllers while earlier conventional controllers had many limitations and constraints like very low reliability. Three phase circuits are the first priorities of industrial and large size commercial electrical systems especially electric drives and use of three phase inverters for it is a most commonly used topology in today's era. The Inverter technologies has a vital role in modern power system for efficient operations of adjustable speed drives, Power backup sources and HVDC transmission these are the places where bulk power has to carry and single or common inverter is not capable to handle it. ML Inverter is the solution of such problems at once.

Cascaded H Bridge Inverter has H Bridge in each individual inverter and it may operate like an independent system which gains the input power from equal and independent DC source either through battery bank or using a converter system in case of two stage conversion used for VFD and primary available supply is AC. Cascaded H-bridge inverter consists of a number of H-bridge power conversion cells, each supplied by an isolated source on the DC side and series-connected on the AC side. The carrier frequency is the same as the switch frequency. If the modulation were reduced to Zero or a DC quantity, then the PWM spectrum would consist of the carrier and its harmonics Alone and the component at zero frequency (DC) if present. As the amplitude of the modulating Waveform is increased, sidebands appear and increase in amplitude either side of the carrier and its harmonics. As the frequency of the modulating waveform is increased, the sidebands spread Away from the central carrier frequency. The carrier frequency should be synchronous, that is an integer multiple of the fundamental frequency, if the pulse number is low. The utility power supply is of constant frequency, and it is 50 or 60Hz. Since the speed of ac machines is proportional to the frequency of input voltages and currents, they have a fixed speed

when supplied from power utilities. A number of modern manufacturing processes, such as machine tools, require variable speed.

II. MULTI LEVEL INVERTER

The multilevel inverters came into existence few decades earlier and the concept behind this is to utilize more number of solid state switches to perform energy conversion in small steps. The number of advantages is present for doing this:

- first one is to produce higher quality wave form
- To Reduce dv/dt stresses
- To Reduce the electromagnetic compatibility concerns
- Due to series connection solid state devices may operate at higher voltage levels

III. SEVEN LEVEL INVERTER FED DRIVE

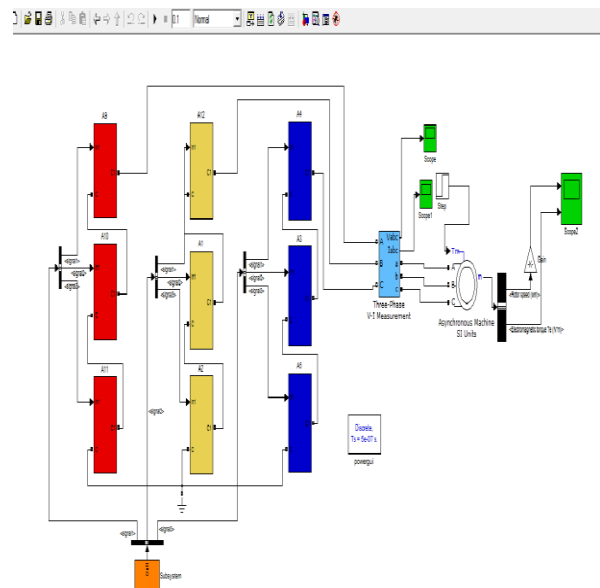

Fig.1 Seven Level Inverter fed Induction Motor Drive

Fig.1 shows the seven level inverter fed induction motor drive, in this model cascade H-bridge seven level inverter is used and this model is connected to an induction motor drive and the result is obtained by the scope.

The Rotor Speed and Torque of seven Level inverter fed Drive are shown in Fig.2

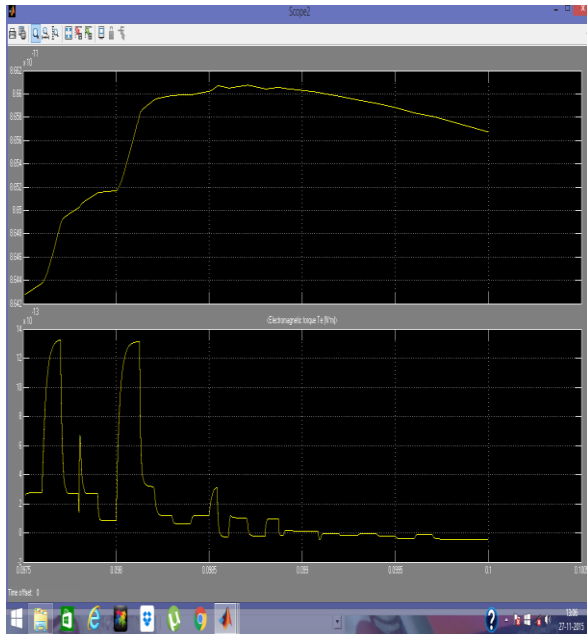

Fig.2 Rotor speed and Torque of seven level inverter

IV. NINE LEVEL INVERTER FED DRIVE

Fig.3 Shows the Nine Level Inverter fed induction motor drive ,in this model cascade H-bridge Nine level inverter used and this model is connected to a induction motor drive and the result obtained by the scope.

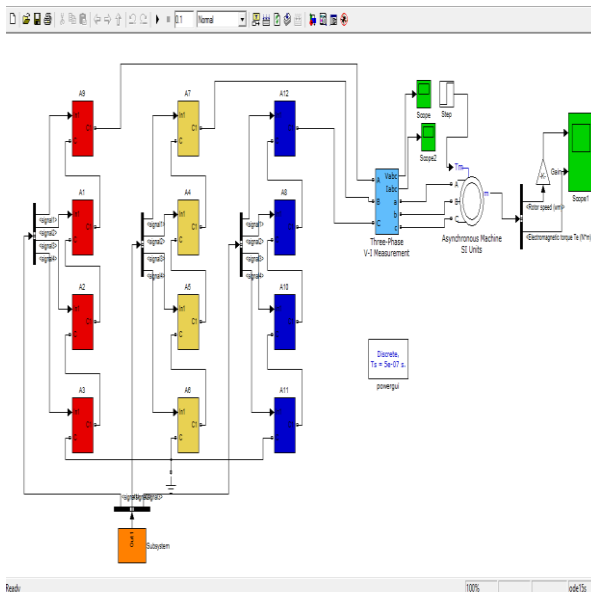

Fig. 3 Nine Level Inverter fed Induction Motor Drive

The Rotor speed and Torque of Nine Level inverter fed Drive are shown in Fig.4

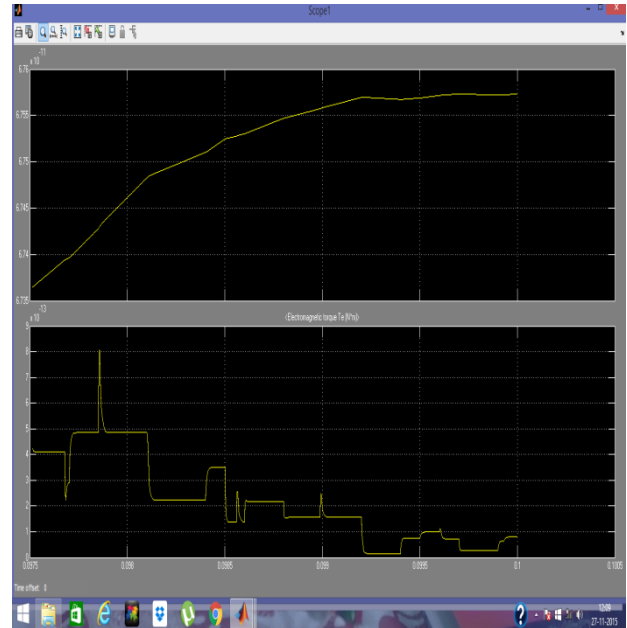

Fig.4 Rotor Speed and Torque of Nine Level Inverter

V. RESULT AND SIMULATION

The table 1 and table 2 given below the Result of seven levels and nine level inverter fed induction motor drive respectively.

TABLE 1 Comparative Result of Seven Level Inverter

Md. Index	Fundamental Freq.	Carrier Freq.	Rotor Speed (rpm)	Torque (N-m)
0.8	40	2500	7.7199×10^{-12}	8.2687×10^{-14}
0.8	50	2500	8.6516×10^{-11}	8.5821×10^{-14}
0.8	60	2500	7.2395×10^{-11}	2.5386×10^{-13}
0.8	70	2500	6.1653×10^{-11}	7.7065×10^{-13}
0.9	50	2500	1.9654×10^{-11}	2.1484×10^{-13}
1.0	50	2500	1.0942×10^{-10}	3.0909×10^{-12}
1.1	50	2500	2.8847×10^{-9}	1.8904×10^{-12}
0.8	50	1500	5.3735×10^{-9}	2.5776×10^{-13}
0.8	50	2000	8.0052×10^{-11}	1.3148×10^{-12}
0.8	50	3000	6.004×10^{-11}	9.3896×10^{-14}

TABLE 2 Comparative Result of Nine Level Inverter

Md. Index	Fundamental Freq.	Carrier Freq	Rotor Speed(rpm)	Torque (N-m)
0.8	40	2500	8.3683×10^{-11}	2.1841×10^{-13}
0.8	50	2500	6.7114×10^{-11}	4.1981×10^{-13}
0.8	60	2500	5.5421×10^{-11}	3.8428×10^{-13}
0.8	70	2500	4.7773×10^{-11}	3.8357×10^{-13}
0.9	50	2500	2.1512×10^{-10}	7.2448×10^{-13}
1.0	50	2500	8.1608×10^{-10}	2.8773×10^{-12}
1.1	50	2500	3.0728×10^{-9}	9.09455×10^{-12}
0.8	50	1500	6.2566×10^{-11}	1.6817×10^{-13}
0.8	50	2000	6.7452×10^{-11}	4.8634×10^{-13}
0.8	50	3000	6.2428×10^{-11}	4.5084×10^{-13}

VI. CONCLUSION

The proposed model has shown excellent result for industrial applications of MLI fed drive. The induction

motor drive not only increases the reliability but reduces maintenance too.

REFERENCES

- [1] Farid khoucha, Soumia mouna lagoun, Khoudir Marouani. "Hybrid Cascaded H-Bridge Multilevel-Inverter Induction –Motor-Drive Direct Torque Control for Automotive Applications" IEEE Transactions On Industrial Electronics, Vol.57, NO.3, March 2010.
- [2] Liming Liu,Hui Li, Senior Member ,IEEE."An Energy-Efficient Motor Drive With Autonomous Power Regenerative Control System Based on Cascaded Multilevel Inverters and Segmented Energy Storage."IEEE Transactions On Industry Application, Vol.49,No.1,January/February 2013.
- [3] Chinnathambi Gvindaraju, Kaliaperumal, "Power Loss Minimizing Control of Cascaded Multilevel Inverter with Effective Hybrid Carrier Based Space Vector Modulation."International Journal of Electrical and Computer Engineering System, Vol.1,No.1,June 2010.
- [4] G.Sudhakar and S.Prabhakaran, "Design of nine Level Inverter Topology for Three Phase Induction Motor Drives." Bonfring International Journal of Power System and Integrated Circuits, Vol.4, No.1, February 2014.
- [5] Atif Iqbal, Sk Moin Ahmed, Mohammed Arif Khan," Generalized Simulation and Experimental Implementation of Space Vector PWM Technique of a Three-Phase Voltage Inverter."International Journal of Engineering Science and Technology, Vol.2, No.1, 2010, pp.1-12.
- [6] Mr.Sandeep N Panchal,Mr.Vishal S Sheth,Mr. Akshay A Pandya," Simulation Analysis of SVPWM Inverter Fed Induction Motor Drives."International Journal of Emerging Trends in Electrical and Electronics, Vol.2, Issue 4, April-2013.
- [7] Abdolreza Esmaeli,Mohsen Mobini, " Research and Development Random Pulse Width Modulation."International Research Journal of Applied and Basic Sciences, Vol.6(9), 1243-1248, 2013.
- [8] M.lakshmi Swarupa,G.Tulasi Ram Das and P.V.Raj Gopal,"Simulation and Analysis of SVPWM Based 2-level and 3-Level Inverters for Direct Torque of Induction Motor." International Journal of Electronic Engineering Research, Vol.1,No.3,2009 pp.169-184.
- [9] A. Salami, B. Bayat, "Total Harmonic Distortion Minimization of Multilevel Converters Using Genetic Algorithms."Applied Mathematics, July 2013,4 1023-1027.
- [10] Haiwen Liu,leon M.Tolbert,Surin Khomfoi."Hybrid Cascaded Multilevel Inverter With PWM Control Method,"IEEE Transaction,2008.
- [11] M.Sasikumar and S.Chenthur pandian."Modelling and Analysis of Cascaded H-Bridge Inverter for Wind Driven Isolated Self-Excited Induction Generators."International Journal on Electrical Engineering and Informatics, Vol.3, No.2, 2011.
- [12] V. Vinothkumar, Dr.C. Muniraj. "Fault Diagnosis in H-Bridge Multilevel Inverter Drive Using Wavelet Transforms."International Journal of Advanced Research in Electrical Electronics and Instrumentation Engineering, Vol.2, Issue 4, April 2013.
- [13] A.Pradeep kumar, B.Vamsilkrishan."Z-Source Cascaded Multilevel Inverter Fed IM for Selective Harmonic Minimization and THD Reduction with PV Cell Input."International Journal of Scientific Engineering and Research, Vol.2,Issue 4, April 2014,pp 38-43
- [14] Amrita Tuteja, Dr.Amita Mahar, Aarti Sirsat."A Review on Mitigation of Harmonics in Cascaded H-bridge Multilevel Inverter Using Optimization Techniques."International Journal of Emerging Technology and Advanced Engineering, Vol.3.Issue 2, February 2013.
- [15] C.Govindraju and Dr.K.Baskaran." Optimized Hybrid Phase Disposition PWM Control Method for Multilevel Inverter."International Journal of Recent Trends in Engineering,Vol.1, No.3, May 2009.
- [16] Anggun Anugrah, 2Marizan Sulaiman,Rosli Omar." Space Vector Analysis in Electrical Drives for Single-Phase Induction Motor Using MATLAB/SIMULINK." Journal of Theoretical and Applied Information Technology, 2005-2009,pp 710-719
- [17] R.Dharmaprakash,Joseph Henry." Direct Torque Control of Induction Motor Using Multilevel Inverter." International Journal of Latest Research in Science and Technology, Vol.3, Issue 3: Page No. 70-75, May 2014.
- [18] Neha Guptaand A.K.Pnadey." A Review:Space Vector PWM Z-source Inverter Fed Induction Motor Drive." VSRD-International

Journal of Electrical Electronics & Communication Engineering, Vol.2 (8), 2012, 650-658.

- [19] T.Laskody,S.Kascak,M.Prazenica,B.Dobrucuky,"Space Vector PWM for Two-Phase Inverter in MATLAB-SIMULINK"
- [20] Manasa S, Balaji Ramakrishna S, Madhura S and Mohan H.M. "Design and Simulation of Three Phase Five Level and Seven Level Inverter Fed Induction Motor Drive with Two Cascaded
- [21] Kapil Jain, Pradyumn Chaturvedi. "Matlab-Based Simulation and Analysis of Three-Level SPWM Inverter." International Journal of Soft Computing and Engineering,Vol.2, Issue-1, March 2012.
- [22] Cheeka G.K. Ayyappa Kumar, V.Anjani Babu, K.R.N.V. Subba Rao." Performance and Analysis of Hybrid Multilevel inverter fed Induction Motor Drive." International Journal of Modern Engineering Research, Vol. 2, Issue.2, Mar-Apr 2012 pp-346-353.
- [23] K. Lavanya, V. Rangavalli. "A Novel Technique for Simulation and Analysis of SVPWM Two and Three Level Inverters." International Journal of Engineering Research and Application, Vol.3, Sep-Oct 2013, pp.455-460.
- [24] Karthika N,Sangari A,Umamahesheswari R,"Perforamnce Analysis of Multilevel Inverter with DC Link Switches for Renewable Energy Resources."International Journal of Innovative Technology and Exploring Engineering,Vol-2,May 2013.
- [25] C. Govindaraju, K. Baskaran, "Performance improvement of Multiphase Multilevel Inverter Using Hybrid Carrier Based Space Vector Modulation." International Journal on Electrical Engineering and Infomatics, Vol-2, Number 2,2010.
- [26] Sourabh Mehto,Rahul Agrawal, Manish Shah,"A Comaparative Studey Based on PI and Fuzzy Control of Inverter fed Induction Motor Drive." International Journal Of Reasearch, Vol-2 February 2015,pp 75-79.
- [27] Juhi Nagpal,Rahul Agrawal, Manish Shah," Acomparative study on Different Speed Control Methods of D.C. Drives for Electric Vehicle." International Journal of Research, Vol-2.July 2015,pp 1-6.

BIOGRAPHIES



Jyoti Verma- pursuing M.Tech in Power Electronics from Vindhaya Institute of Technology and Science Indore, MP (INDIA).She completed B.E. in 2010 from MIT Mandasaur. Her field of interest for research in Power Electronics, Electric Machine, Electric Drive.



Manish Shah- was born in Khargone (M.P.), India. Presently he is working as Asst. Prof. VITS Indore, India. He has vast industrial and few years of teaching experience. He is a registered competent person under factory act Govt. of M.P. India, Chartered Engineer (I) competent person department of Energy Govt. of M.P. India and members of various professional bodies like IEEE, IE, ISLE. He has contributed few publications in national and international conferences & Journals. His current research areas are Load forecasting, Soft Computing Techniques, energy efficient machines, innovation in industrial safety, LOTO, Analysis and prevention of electrical hazards.