

Implementation of a Closed Loop Control System to Improve DVR Response

A.V. Ravi Kumar¹, K. Nagalinga Chary², P. Srihari³

Assistant Professor, EEE Dept, Lakireddy Bali Reddy College of Engineering, Mylavaram, Andhra Pradesh, India^{1,2,3}

Abstract: Voltage sag and voltage swell are two of the most important power-quality problems that encompass almost 85% of the distribution system power quality problems. The dynamic voltage restorer (DVR) is one of the modern devices used in distribution systems to protect consumers against sudden changes in voltage amplitude. In this paper, a multifunctional DVR control strategy is proposed along with Posicast and P+Resonant controllers. With the help of these controllers the transient response of DVR can be improved and also in DVR response, the steady state error can be eliminated.

Keywords: Dynamic voltage restorers (DVR), power quality, voltage sag, voltage swell.

I. INTRODUCTION

According to voltage sag, it can be found that this is a transient phenomenon whose causes are classified as low- or medium-frequency transient events. In recent years, considering the use of sensitive devices in modern industries, different methods of compensation of voltage sags have been used. One of these methods is using the DVR to improve the PQ and compensate the load voltage. The multiline DVR can be used for eliminating the battery in the DVR structure and controlling more than one line. Moreover, research has been made on using the DVR in medium level voltage. Harmonic mitigation and control of DVR under frequency variations are also in the area of research.

The closed-loop control with load voltage and current feedback is introduced as a simple method to control the DVR. Also, Posicast and P+Resonant controllers can be used to improve the transient response and eliminate the steady-state error in DVR. The Posicast controller is a kind of step function with two parts and is used to improve the damping of the transient oscillations initiated at the start instant from the voltage sag. The P+Resonant controller consists of a proportional function plus a resonant function and it eliminates the steady-state voltage tracking error.

II. VOLTAGE SAG

Voltage sags and momentary power interruptions are probably the most important PQ problem affecting industrial and large commercial customers. These events are usually associated with a fault at some location in the supplying power system. Interruptions occur when the fault is on the circuit supplying the customer. But voltage sags occur even if the faults happen to be far away from the customer's site. Voltage sags lasting only 4-5 cycles can cause a wide range of sensitive customer equipment to drop out.

To industrial customers, voltage sag and a momentary interruption are equivalent if both shut their process down. The susceptibility of utilization equipment to voltage sag is dependent upon duration and magnitude of voltage sags. Voltage sags which can cause equipment impacts are caused by faults on the power system. Motor starting also results in voltage sags but the magnitudes are usually not severe enough to cause equipment misoperation.

Based upon the utilities reliability data (the number of times each line section will experience a fault) and the results of load flow and voltage sag calculations, the number of voltage sags at the customer site due to remote faults can be calculated. Depending upon the equipment connection, the voltage sag occurrence rate may be calculated in terms of either phase or line voltages dependent upon the load connection.

For some facilities, both line and phase voltages may be required. The data thus obtained from load flow, Voltage sag calculation, and voltage sag occurrence calculation can be sorted and tabulated by sag magnitude, fault type, location of fault and nominal system voltage at the fault location.

III. DYNAMIC VOLTAGE RESTORER

When the fast variations in the source voltage cannot be ignored, these can affect the performance of critical loads such as (a) semiconductor fabrication plants (b) paper mills (c) food processing plants and (d) automotive assembly plants. The most common disturbances in the source voltages are the voltage sags or swells that can be due to (i) disturbances arising in the transmission system, (ii) adjacent feeder faults and (iii) fuse or breaker operation. Voltage sags of even 10% lasting for 5-10 cycles can result in costly damage in critical loads. The voltage sags can arise due to symmetrical or unsymmetrical faults. In the latter case, negative and zero

sequence components are also present. Uncompensated nonlinear loads in the distribution system can cause harmonic components in the supply voltages. To mitigate the problems caused by poor quality of power supply, series connected compensators are used.

These are called as Dynamic Voltage Restorer (DVR) in the literature as their primary application is to compensate for voltage sags and swells. However, the control techniques are different. Also a DVR is expected to respond fast (less than 1/4 cycle) and thus employs PWM converters using IGBT or IGCT devices.

Several DVRs have been installed to protect microprocessor fabrication plants, paper mills etc. Typically, DVRs are made of modular design with a module rating of 2 MVA or 5 MVA. They have been installed in substations of voltage rating from 11 kV to 69 kV. A DVR has to supply energy to the load during the voltage sags. If a DVR has to supply active power over longer periods, it is convenient to provide a shunt converter that is connected to the DVR on the DC side. As a matter of fact one could envisage a combination of DSTATCOM and DVR connected on the DC side to compensate for both load and supply voltage variations. In this section, we discuss the application of DVR for fundamental frequency voltage.

The power circuit of DVR shown in Fig.(a) has four components listed below

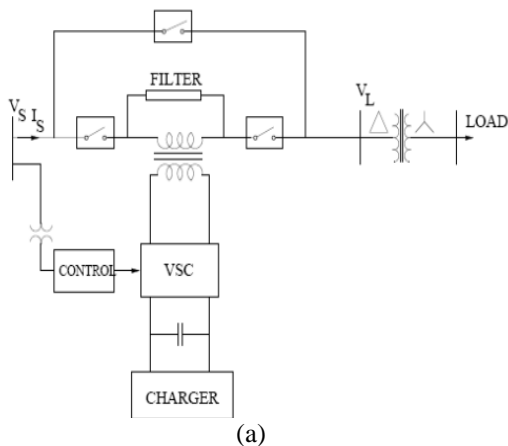

(a) Voltage Source Converter (VSC):-

This could be a 3 phase - 3 wire VSC or 3 phase - 4 wire VSC. The latter permits the injection of zero-sequence voltages. Either a conventional two level converter (Graetz Bridge) or a three level converter is used.

(b) Boost or Injection Transformers:-

Three single phase transformers are connected in series with the distribution feeder to couple the VSC (at the lower voltage level) to the higher distribution voltage level. The three single transformers can be connected with star/open star winding or delta/open star winding. The latter does not permit the injection of the zero sequence voltage. The choice of the injection transformer winding

depends on the connections of the step down transformer that feeds the load. If Δ -Y connected transformer (as shown in Fig.3.1) is used, there is no need to compensate the zero sequence voltages.

However if Y-Y connection with neutral grounding is used, the zero sequence voltage may have to be compensated. It is essential to avoid the saturation in the injection transformers.

(c) Passive Filters:-

The passive filters can be placed either on the high voltage side or the converter side of the boost transformers.

The advantages of the converter side filters are

- The components are rated at lower voltage
- Higher order harmonic currents do not own through the transformer windings.

The disadvantages are that the filter inductor causes voltage drop and phase (angle) shift in the (fundamental component of) voltage injected. This can affect the control scheme of DVR. The location of the filter on the high voltage side overcomes the drawbacks (the leakage reactance of the transformer can be used as a filter inductor), but results in higher ratings of the transformers as high frequency currents can flow through the windings.

(d) Energy Storage:-

This is required to provide active power to the load during deep voltage sags. Lead-acid batteries can be used for energy storage. It is also possible to provide the required power on the DC side of the VSC by an auxiliary bridge converter that is fed from an auxiliary AC supply.

IV. MULTIFUNCTIONAL DVR

In addition to the aforementioned capabilities of DVR, it can be used in the medium-voltage level to protect a group of consumers when the cause of disturbance is in the system.

Downstream of the DVR's feeder and the large fault current passes through the DVR itself. In this case, the equipment can limit the fault current and protect the loads in parallel feeders until the breaker works and disconnects the faulted feeder. The large fault current will cause the PCC voltage to drop and the loads on the other feeders connected to this bus will be affected.

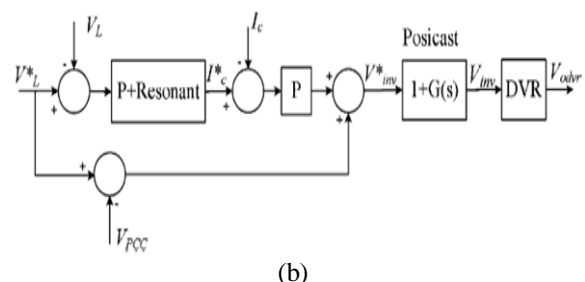

Furthermore, if not controlled properly, the DVR might also contribute to this PCC voltage sag in the process of compensating the missing voltage, hence further worsening the fault situation

The block diagram of Multi-loop control using the Posicast and P+Resonant controllers is shown in fig(b). To limit the fault current, a flux-charge model has been proposed and used to make DVR act like a pure virtual inductance which does not take any real power from the external system and, therefore, protects the dc-link capacitor and battery.

In this paper, the PCC voltage is used as the main reference signal and the DVR acts like variable impedance. For this reason, the absorption of real power is harmful for the battery and dc-link capacitor. To solve this problem, impedance including a resistance and an inductance will be connected in parallel with the dc-link capacitor.

In this part, an algorithm is implemented for the DVR to restore the PCC voltage, limit the fault current, and, therefore, protect the DVR components. The flux-charge model here is used in a way so that the DVR acts as a virtual inductance with a variable value in series with the distribution feeder. To do this, the DVR must be controlled in a way to inject a proper voltage having the opposite polarity with respect to usual cases. It should be noted that over current tripping is not possible in this case, unless additional communication between the DVR and the downstream side over current circuit breaker (CB) is available. If it is necessary to operate the over current CB at PCC, communication between the DVR and the PCC breaker might have to be made and this can be easily done by sending a signal to the breaker when the DVR is in the fault-current limiting mode as the DVR is just located after PCC. This DVR control method is illustrated in Fig(c).

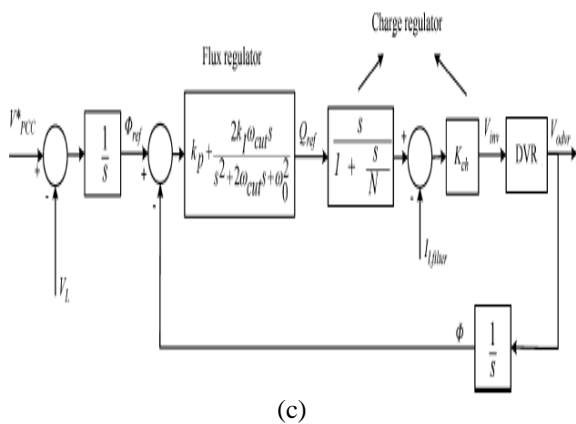

V. SIMULATION RESULTS

In this part, the proposed DVR topology and control algorithm will be used for emergency control during the voltage sag.

The three-phase short circuit and the start of a three-phase large induction motor will be considered as the cause of distortion in the simulations.

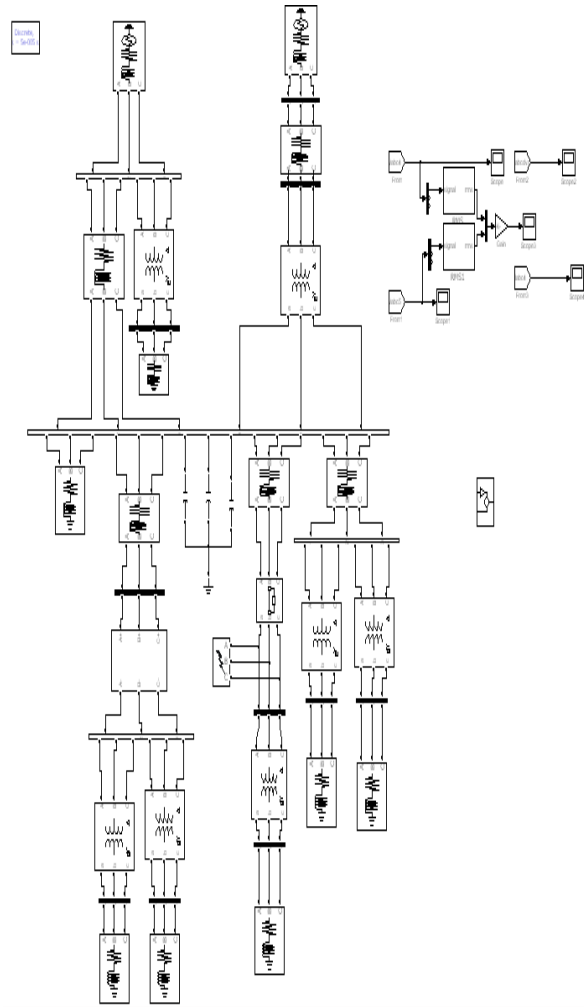

The simulink diagram is shown in fig(d). The different simulation waveforms with DVR compensation are shown in following figures.

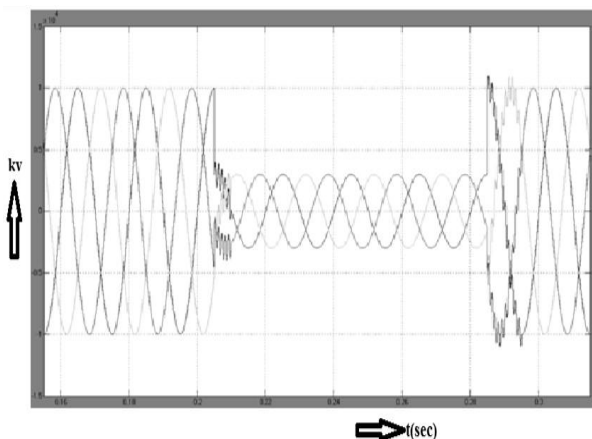

Fig(e). Three-phase PCC voltages.

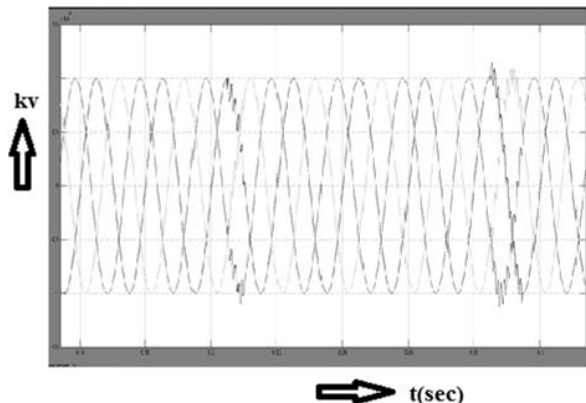

Fig(e).Three-phase load voltages.

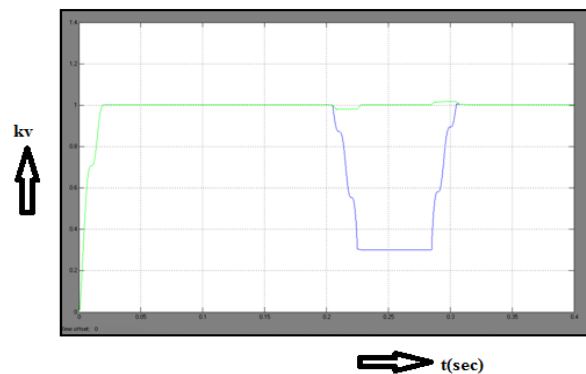

Fig (f) RMS voltages of PCC and load

The DVR will start the compensation just after the detection of sag. As can be seen in the enlarged figure, the DVR has restored the voltage to normal form with attenuation of the oscillations at the start of the compensation in less than half a cycle. It is worth noting that the amount and shape of the oscillations depends also on the time of applying the fault. As can be seen in the enlarged figure, the voltage value of phase B is nearly zero; this phase has minimum oscillation when the fault starts.

VI. CONCLUSION

The problem of absorbed active power is solved by entering impedance just at the start of this kind of fault in parallel with the dc-link capacitor and the battery being connected in series with a diode so that the power does not enter it. The simulation results verify the effectiveness and capability of the DVR in compensating for the voltage sags caused by short circuits and limiting the downstream fault currents and protecting the PCC voltage.

In this paper, a multifunctional DVR is implemented, and a closed-loop control system is used for its control to improve the damping of the DVR response. Also for further improving the transient response and eliminating the steady-state error, the Posicast and P+Resonant controllers are used. As the second function of this DVR, using the flux-charge model, the equipment is controlled

so that it limits the downstream fault currents and protects the PCC voltage during these faults by acting as a variable impedance.

REFERENCES

- [1] M. I. Marei, E. F. El-Saadany, and M. M. A. Salama, "A new approach to control DVR based on symmetrical components estimation," *IEEE Trans. Power Del.*, vol. 22, no. 4, pp. 2017–2024, Oct. 2007.
- [2] Y. W. Li, D. M. Vilathgamuwa, F. Blaabjerg, and P. C. Loh, "A robust control scheme for medium-voltage-level DVR implementation," *IEEE Trans. Ind. Electron.*, vol. 54, no. 4, pp. 2249–2261, Aug. 2007.
- [3] S. A. Saleh, C. R. Moloney, and M. A. Rahman, "Implementation of a dynamic voltage restorer system based on discrete wavelet transforms," *IEEE Trans. Power Del.*, vol. 23, no. 4, pp. 2360–2375, Oct. 2008.
- [4] S. S. Choi, B. H. Li, and D. M. Vilathgamuwa, "Dynamic voltage restoration with minimum energy injection," *IEEE Trans. Power Syst.*, vol. 15, no. 1, pp. 51–57, Feb. 2000.