

# Multi Scale Decomposition and Edge Preserving Filter Based Satellite Image Resolution Enhancement - A Review

Manjoor.Syed<sup>1</sup>, S Naga Kishore Bhavanam<sup>2</sup>

M.Tech Student, Department of ECE ,University College of Engineering &Technology,  
Acharya Nagarjuna University, Guntur,AP, India<sup>1</sup>

<sup>2</sup>Assistant Professor, Department of ECE ,University College of Engineering &Technology,  
Acharya Nagarjuna University, Guntur,AP, India<sup>2</sup>

**Abstract:** Resolution enhancement (RE) schemes which are not based on wavelets has one of the major drawbacks of losing high frequency contents which results in blurring. The discrete wavelet- transform-based (DWT) Resolution Enhancement scheme generates artifacts (due to a DWT shift-variant property). A wavelet-Domain approach based on dual-tree complex wavelet transform (DT-CWT) & nonlocal means (NLM) is proposed for RE of the satellite images. A satellite input image is decomposed by DT-CWT (which is nearly shift invariant) to obtain high-frequency sub bands. Here the Lanczos interpolator is used to interpolate the high-frequency sub bands & the low-resolution (LR) input image. The high frequency sub bands are passed through an NLM filter to cater for the artifacts generated by DT-CWT (despite of its nearly shift invariance). The filtered high-frequency sub bands and the LR input image are combined by using inverse DT-CWT to obtain a resolution-enhanced image. Objective and subjective analyses show superiority of the new proposed technique over the conventional and state-of-the-art RE techniques.

**Index Terms:** Dual-Tree Complex Wavelet Transform (DT-CWT), Lanczos Interpolation, Resolution Enhancement (RE), shift variant.

## I. INTRODUCTION

Resolution (spatial, spectral, and temporal) is the limiting factor for the utilization of remote sensing data by satellite imaging, etc. In satellite image Spatial and spectral resolutions are related (a high spatial resolution is associated with a low spectral resolution and vice versa) with each other [1]. So, spectral, as well as spatial, resolution enhancement (RE) is most by desirable. Interpolation has been widely used for RE [2], [3]. Commonly used interpolation techniques are based on nearest neighbors include nearest neighbor, bilinear, bi-cubic, and Lanczos. The Lanczos interpolation (windowed form of a sinc filter) is superior than its counterparts (including nearest neighbor, bilinear, and bi-cubic) because it has increased ability to detect edges and linear features. And it also offers the best compromise in terms of reduction of aliasing, sharpness, and ringing [4].

The Methods based on vector-valued image regularization with partial differential equations (VVIR-PDE) [5] and in painting and zooming using sparse representations [6] are now state of the art in the field (i.e., mostly applied for image in painting but can be also seen as interpolation). RE schemes which are not based on wavelets suffer from one major drawback of losing high frequency contents which results in blurring. RE by using

wavelet domain is a new research area, and recently, many algorithms DWT [7], stationary wavelet transform (SWT) [8], and dual-tree complex wavelet transform (DT-CWT) [9] have been proposed [7]–[11].

An RE scheme was proposed by using DT-CWT and bicubic interpolations, and results were compared shown superior) with the conventional schemes (i.e., nearest neighbor, bilinear, and bicubic interpolations and wavelet zero padding) [9]. More recently in [7], a scheme based on DWT and bicubic interpolation was proposed, and results were compared with the conventional schemes and the state-of-art schemes (wavelet zero padding and cyclic spinning [12] and DT-CWT [9]). But, DWT is shift variant, which causes the artifacts in the RE image, and has a lack of directionality; so, DT-CWT is almost shift and rotation invariant [13]. DWT-based RE schemes generate artifacts (due to DWT shift-variant property). In this paper, a DT-CWT-based nonlocal-means-based RE (DT-CWT-NLM-RE) technique is proposed, using the DT-CWT, Lanczos interpolation, and NLM. This DT-CWT technique is nearly shift invariant and directional selective. Moreover, DT-CWT preserved the usual properties of perfect reconstruction with well-balanced frequency responses [13], [14]. Consequentially, DT-CWT gives better results after the

modification of the wavelet coefficients and provides less artifacts, as compared with traditional DWT. Since the Lanczos filter offer less aliasing, sharpness, and minimal ringing, so, this one is the better choice for RE.

NLM filtering [15] is used to further enhance the performance of DT-CWT-NLM-RE by reducing the artifacts. The results for spatial RE of optical images are compared with the best performing techniques [5], [7]–[9].

## II. LITERATURE REVIEW

*Existing method:*

- Discrete Wavelet Transform
- Stationary Wavelet Transform
- Nearest neighbour based pixel insertion

*Proposed method:*

Resolution enhancement of low resolution satellite image base on,

- Dual Tree CWT multi scale decomposition
- Neighbourhood insertion with interpolation technique
- Edge Preserving filter- Non local means

## III. PRELIMINARIES

### A. NLM Filtering

The NLM filter (an extension of neighborhood filtering algorithms) is based on the assumption that image content is likely to repeat itself within some neighborhood (in the image) [15] and in neighboring frames [16]. It computes denoised pixel  $x(p, q)$  by the weighted sum of the surrounding pixels of  $Y(p, q)$  (within frame and in the neighboring frames) [16]. This feature provides a way to estimate the pixel value from noisecontaminated images. In a 3-D NLM algorithm, the estimate position i.e,  $(p, q)$  of a pixel is

$$x(p, q) = \frac{\sum_{m=1}^M \sum_{(r,s) \in N(p,q)} Y_m(r,s) K_m(r,s)}{\sum_{m=1}^M \sum_{(r,s) \in N(p,q)} K_m(r,s)} \quad (1)$$

Where  $m$  is the frame index, and  $N$  represents the neighborhood of the pixel at location  $(p, q)$ .  $K$  values are the filter weights, i.e.

$$K(r, s) = \exp \left\{ -\frac{\|V(p, q) - V(r, s)\|_2^2}{z^2} \right\} \times f(\sqrt{(p-r)^2 + (q-s)^2 + (m-1)^2}) \quad (2)$$

Where  $V$  is the window usually a square window centered at the pixels  $Y(p, q)$  and  $Y(r, s)$  of pixel values from a

geometric neighborhood of pixels  $Y(p, q)$  and  $Y(r, s)$ ,  $\sigma$  is the filter coefficient, and  $f(\cdot)$  is a geometric distance function.  $K$  is inversely proportional to the distance between  $Y(p, q)$  and  $Y(r, s)$ .

### B. NLM-RE

Resolution Enhancement is achieved by modifying NLM with the following model proposed in [17]:

$$L_m = IJQX + n \quad (3)$$

Where  $L_m$  indicates vectorized low-resolution (LR) frame,  $I$  is the decimation operator,  $J$  is the blurring matrix,  $Q$  is the warping matrix,  $X$  is the vectorized high-resolution (HR) im image, and  $n$  denotes the Gaussian white noise. The aim is to restore  $X$  from a series of  $L$ . Penalty function  $\epsilon$  is defined as;

$$\epsilon^2 = \frac{1}{2} \sum_{m=1}^M \|IJQx - Y_m\|_2^2 + \lambda R(x) \quad (4)$$

Where  $M$  is a regularization term,  $\lambda$  is the scale coefficient,  $x$  is the targeted image, and  $Y_m$  is the LR input image. The total variation kernel is chosen to replace  $R$ , acting as an image deblurring kernel by [17]. To simplify the algorithm, a separation of the problem in (4) is done by minimizing

$$\epsilon_{fusion}^2(Z) = \frac{1}{2} \sum_{m=1}^M (IQZ - L_m)^T O_m (IQZ - L_m) \quad (5)$$

Where  $Z$  is the blurred version of the targeted image, and  $O_m$  is the weight matrix, followed by minimizing a deblurring equation [11], i.e.,

$$\epsilon_{RE}^2(X) = \|JX - Z\|_2^2 + \lambda R(Z) \quad (6)$$

Pixel wise solution of (5) can be obtained as

$$\hat{z} = \frac{\sum_{m=1}^M \sum_{(r,s) \in N(p,q)} Y_m^r(r,s) K_m^r(r,s)}{\sum_{m=1}^M \sum_{(r,s) \in N(p,q)} K_m^r(r,s)} \quad (7)$$

Where the superscript  $r$  refers to the HR coordinate. Instead of estimating the target pixel position in nearby frames, this algorithm considers that all possible positions where the pixel may appear. Therefore, motion estimation is avoided [11]. Equation (7) apparently resembles (1), but (7) has some differences as compared with (1). The weight estimation in (2) should be modified because ' $K$ ' is corresponding matrix  $O$  has to be of the same size as the HR image. Therefore, a simple up scaling process to patch  $V$  is needed before computing the  $K$ . The total number of pixel  $Y$  in (7) should be equal to the number of weights  $K$ . Thus, a zero-padding interpolation is applied to  $L$  before fusing the images [11].

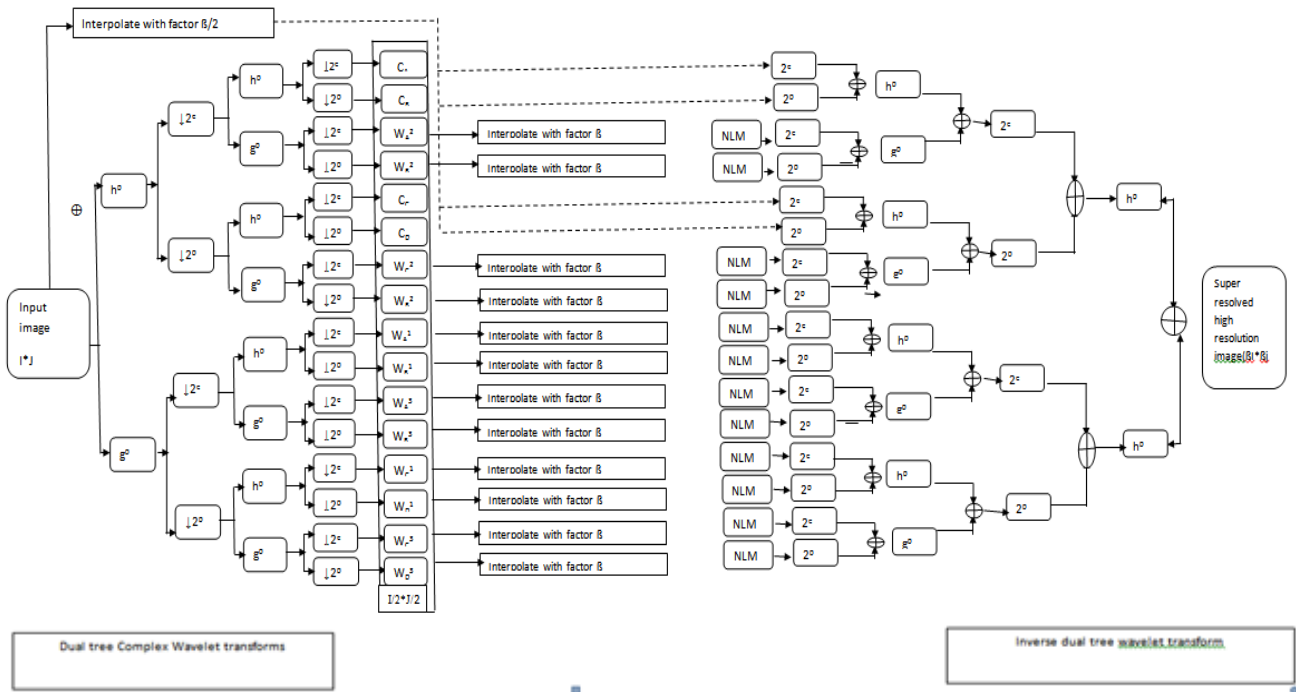

Courtesy from Satellite Imaging Corporation

Fig: 1 Block Diagram of the Proposed DT-CWT-RE Algorithm

#### IV. PROPOSED BLOCK DIAGRAM

In the proposed model we decompose the LR input image in different sub bands by using DT-CWT. The obtained Values are interpolated by factor  $\beta$  using the Lanczos interpolation and Combined with the  $\beta/2$ -interpolated LR input image, to remove artifacts, NLM filtering is used. All interpolated values are passed through the NLM filter. After that we apply the inverse DT-CWT to these filtered sub bands along with the interpolated LR input image to reconstruct the HR image.

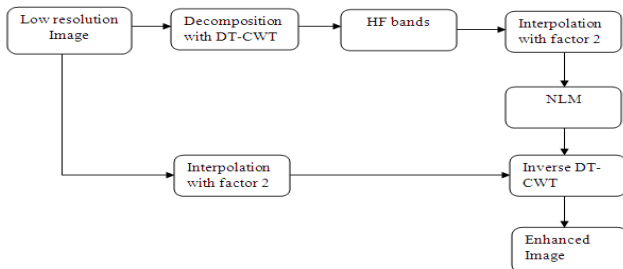

Fig. 2 Proposed Block Diagram

#### V. CONCLUSION

In this paper an RE technique based on DT-CWT and an NLM filter has been proposed. This technique decomposes the LR input image using DT-CWT. By using the Lanczos interpolator Wavelet coefficients and the LR input image

was interpolated. This DT-CWT is nearly shift invariant and generates fewer artifacts as compared with DWT.

NLM filtering is used to overcome the artifacts generated by the DT-CWT and to further enhance the performance of the proposed technique in terms of MSE, PSNR, and Q-index. Experimental results show the superior performance of proposed techniques.

#### ACKNOWLEDGMENT

The authors would like to thank Satellite Imaging Corporation for providing satellite images for research purpose and the higher authorities of Acharya Nagarjuna University. I extend my greatfull thanks to Dr. P. Siddaiah garu, DEAN, for allowing me to use ISRO R&D Lab.

#### REFERENCES

- [1] Y. Piao, I. Shin, and H. W. Park, "Image resolution enhancement using inter-subband correlation in wavelet domain," in Proc. Int. Conf. ImageProcess., San Antonio, TX, 2007, pp. I-445–I-448.
- [2] C. B. Atkins, C. A. Bouman, and J. P. Allebach, "Optimal image scaling using pixel classification," in Proc. Int. Conf. Image Process., Oct. 7–10, 2001, pp. 864–867.
- [3] A. S. Glassner, K. Turkowski, and S. Gabriel, "Filters for common resampling tasks," in Graphics Gems. New York: Academic, 1990, pp. 147–165.
- [4] D. Tschumperle and R. Deriche, "Vector-valued image regularization with PDE's: A common framework for different applications," IEEE Trans. Pattern Anal. Mach. Intell., vol. 27, no. 4, pp. 506–517, Apr. 2005.

- [5] M. J. Fadili, J. Starck, and F. Murtagh, "Inpainting and zooming using sparse representations," *Comput. J.*, vol. 52, no. 1, pp. 64–79, Jan. 2009.
- [6] H. Demirel and G. Anbarjafari, "Discrete wavelet transform-based satellite image resolution enhancement," *IEEE Trans. Geosci. Remote Sens.*, vol. 49, no. 6, pp. 1997–2004, Jun. 2011.
- [7] H. Demirel and G. Anbarjafari, "Image resolution enhancement by using discrete and stationary wavelet decomposition," *IEEE Trans. Image Process.*, vol. 20, no. 5, pp. 1458–1460, May 2011.
- [8] H. Demirel and G. Anbarjafari, "Satellite image resolution enhancement using complex wavelet transform," *IEEE Geosci. Remote Sens. Lett.*, vol. 7, no. 1, pp. 123–126, Jan. 2010.
- [9] H. Demirel and G. Anbarjafari, "Image super resolution based on interpolation of wavelet domain high frequency subbands and the spatial domain input image," *ETRI J.*, vol. 32, no. 3, pp. 390–394, Jan. 2010.
- [10] H. Zheng, A. Bouzerdoum, and S. L. Phung, "Wavelet based non-localmeans super-resolution for video sequences," in *Proc. IEEE 17th Int.Conf. Image Process.*, Hong Kong, Sep. 26–29, 2010, pp. 2817–2820.
- [11] A. Gambardella and M. Migliaccio, "On the superresolution of microwave scanning radiometer measurements," *IEEE Geosci. Remote Sens. Lett.*, vol. 5, no. 4, pp. 796–800, Oct. 2008.
- [12] [Online]. Available: <http://www.satimagingcorp.com/>
- [13] I. W. Selesnick, R. G. Baraniuk, and N. G. Kingsbur, "The dual-tree complex wavelet transform," *IEEE Signal Process. Mag.*, vol. 22, no. 6, pp. 123–151, Nov. 2005.
- [14] J. L. Starck, F. Murtagh, and J. M. Fadili, *Sparse Image and Signal Processing: Wavelets, Curvelets, Morphological Diversity*. Cambridge, U.K.: Cambridge Univ. Press, 2010.
- [15] A. Buades, B. Coll, and J. M. Morel, "A review of image denoising algorithms, with a new one," *Multisc. Model. Simul.*, vol. 4, no. 2, pp. 490–530, 2005.
- [16] A. Buades, B. Coll, and J. M. Morel, "Denoising image sequences does not require motion estimation," in *Proc. IEEE Conf. Audio, Video Signal Based Surv.*, 2005, pp. 70–74.
- [17] M. Protter, M. Elad, H. Takeda, and P. Milanfar, "Generalizing the nonlocal-means to super-resolution reconstruction," *IEEE Trans. Image Process.*, vol. 18, no. 1, pp. 36–51, Jan. 2009.
- [18] Z. Wang and A. C. Bovik, "A universal image quality index," *IEEE Signal Process. Lett.*, vol. 9, no. 3, pp. 81–84, Mar 2002.

## BIOGRAPHIES

**Manjoor Syed** obtained B.Tech degree in Electronics and Communication Engineering from JNTUK in 2011. He is M.Tech (ECE) student at Acharya Nagarjuna University College of Engineering and technology, Guntur, India. His areas of interest are Digital Image Processing and Digital Signal Processing.



**Mr. S NagaKishore Bhavanam** obtained B.Tech degree in Electronics and communication Engineering from S.V.V.S.N Engineering College, Acharya Nagarjuna University, Guntur in 2008, M. Tech Degree from Aurora's Technological & Research Institute, JNT University, Hyderabad in 2010. He is presently pursuing his Ph.D degree from JNTUA, Anantapuram in the area of Signal Processing & Communications. He is currently working as Assistant Professor, Dept. of ECE in University College of Engineering and Technology, Acharya Nagarjuna University, Guntur, India. His interesting fields are Signal Processing, Communications, VLSI and EMFT. He is the student member of IEEE.

