



# Transmit-Diversity for Spatial-Modulation (SM) & Space-Time Block Codes (STBC)

Rahul Saxena<sup>1</sup>, Prof. Rupesh Dubey<sup>2</sup>, Prof. Poonam Lilhare<sup>3</sup>

M.E. Scholar, ECE, IPS Academy, Indore, India <sup>1</sup>

Associate Professor & HOD, ECE, IPS Academy, Indore, India <sup>2</sup>

Asst. Prof, ECE, IPS Academy, Indore, India <sup>3</sup>

**Abstract:** In multiple antenna transmission the multiplexing gain strictly depends on transmit and receive antenna allocation, transmit antenna synchronization and the process used to eliminate the inter channel interference (ICI). Spatial modulation (SM) is a low-complexity scheme for multiple antenna system. The work and research on Spatial Modulation shows that SM is useful to achieve the multiplexing gain for single antenna system. Data is encoded using a space-time block-code (STBCs) and then splits into n streams which are simultaneously transmitted using n transmitted antenna. Maximum-Likelihood (ML) decoding is achieved by a simple way through decoupling of the signals transmitted through different antenna rather than a joint detection. In other words SM is novel modulation techniques which combines the high multiplexing gain provided by the Spatial Modulation and transmit diversity gain provided by the Space-Time Block-Codes (STBCs) technology.

**Keywords:** Multiple-Input Multiple-Output (MIMO) system, Maximum Likelihood decoding, Rayleigh fading channel, Spatial Modulation (SM), Space-Time Block-Codes (STBCs)

## I. INTRODUCTION

The demand of wireless communication system with high data rates has dramatically increased in last decade. The use of wireless communication with multiple transmit and receive antenna has been conducted expansively in the literature on information theory and communications. Multiple-antenna system is a wide area of research. The use of multiple-antenna for wireless communication system has received an upsurge of research interest during the last decade, both in academia and industry [1]. In the realm of the many solutions proposed to date, spatial modulation is a recently proposed modulation scheme that promises a low complexity transmitter and receiver design, along with improved system performance with respect to many state-of-the-art multiple-antenna solutions [2]. It has been known from the information-theoretic results [3], [4] that the application of multiple antennas in wireless communication can significantly improve the channel performance over the single antenna system with the same requirements of power and bandwidth. Space-Time Block coding is a technique used to improve the performance of a wireless transmission system, where the receiver is provided with multiple signals carrying the same information. The concept behind space-time block coding is to transmit multiple copies of the same data through multiple antennas in order to improve the reliability of data-transfer through the noisy channel.

## II. SPATIAL-MODULATION

Spatial modulation aims at reducing the complexity and the cost of multiple-antenna scheme without deteriorating the end-to-end system performance and still guaranteeing the good data-rates. More specifically, the low-complexity transceiver design and high-spectral efficiency are simultaneously achieved by adopting the simple modulation and coding mechanism in what follows:

- 1) Just one transmission antenna is activated for data transmission at any signaling time instance. This allows SM to entirely avoid the ICI, to require no synchronization among the transmission antenna, and to need only one RF chain for data transmission. This allows SM to exploit a low-complexity single-stream

receiver design for optimal maximum-likelihood (ML) decoding.

- The spatial position of each transmit antenna in the antenna array is used as a source of information. This is obtained by establishing a one-to-one mapping between each antenna index and a block of information bits to be transmitted, which results in a coding mechanism that can be called transmit-antenna index coded modulation. This allows SM to achieve a spatial multiplexing gain with respect to conventional single-antenna system.

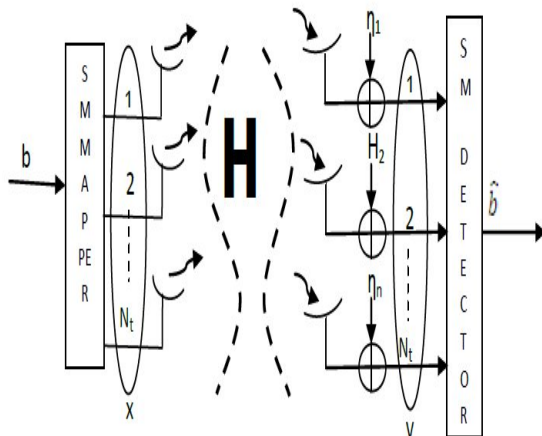

FIG 1 SYSTEM MODEL OF SPATIAL MODULATION

The basic idea of SM is to map a block of information bits into two information carrying units: I) a symbol that is chosen from a complex signal-constellation diagram and II) a unique transmit-antenna index that is chosen from the set of transmit-antenna in the antenna array.

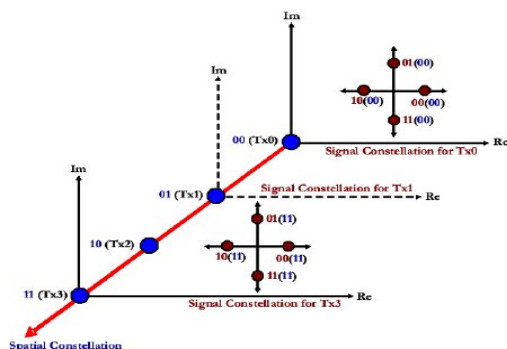

FIG 2 TRIDIMENSIONAL CONSTELLATION DIAGRAM OF SM

The net result of embedding part of the information to be transmitted into the position of the transmit-antenna is a hybrid modulation and MIMO technique in which the modulated signals belongs to a tridimensional constellation

diagram, which jointly combines signal and spatial information. A simple example is shown in above figure [Fig.1] for a linear antenna-array with and a QPSK modulation. When the information carrying unit is only the transmit-antenna index, SM reduces to the so-called space shift keying (SSK) modulation, which avoids any form of conventional modulation and trade-off receiver complexity for achievable data rates.

### III. SPACE-TIME BLOCK CODES (STBC)

Space-Time Block coding is a technique used to improve the performance of a wireless transmission system, where the receiver is provided with multiple signals carrying the same information. The concept behind space-time block coding is to transmit multiple copies of the same data through multiple antennas in order to improve the reliability of data-transfer through the noisy channel. Use of multiple antennas can improve the reliability of data transmission, the method employed for this purpose in wireless communication is known as Space time code (STC) [5]. STCs rely on transmitting Multiple, redundant copies of a data stream to the receiver to allow reliable decoding.

### IV. ORTHOGONAL STBC

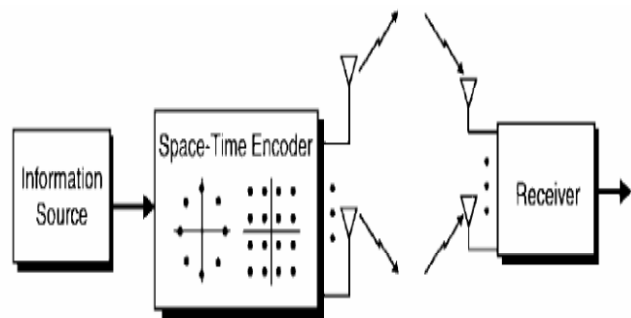

Fig 3 SYSTEMS BLOCK DIAGRAM

Orthogonal space-time block codes (O-STBC) achieve high transmit diversity and have a low complexity decoding algorithm at the receiver using any number of transmit and receive antennas.

In a general form, an STBC can be seen as a mapping of complex symbols  $\{S_1, S_2, \dots, S_N\}$  onto a matrix  $S$  of dimension :

$$\{S_1, S_2, \dots, S_N\} \rightarrow S \quad (1)$$

An STBC code matrix  $S$  taking on the following form:

$$(2)$$

Where is a set of symbols to be transmitted  $= \text{Re} \{ \}$  and  $= \text{Im} \{ \}$ , and with fixed code matrices

of dimensions are called linear STBC. The following STBC can be regulated as special cases of these codes.

### V. ALAMOUTI CODES

The Alamouti code is the first STBC that provides full diversity at full data rate for two transmit antennas [6]. A block diagram of the Alamouti space-time encoder is shown in below figure.

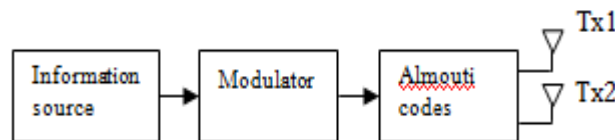

FIG 4 BLOCKS DIAGRAM OF ALAMOUTI SPACE-TIME ENCODER

Where,

$$Tx1 = S_1 = \dots \quad (3)$$

$$Tx2 = S_2 = \dots \quad (4)$$

The information bits are first modulated using an M-ary modulation scheme. The encoder takes the blocks of two modulated symbols  $s_1$  and  $s_2$  in each encoding operation and hands it to the transmit antennas according to the code matrix

$$(5)$$

The first row represents the first transmission period and the second row represents the second transmission period. During the first transmission, the symbol and are transmitted simultaneously from antenna one and antenna two respectively. In the second transmission period, the symbol is transmitted from antenna one and the symbol from antenna two.

It is cleared that the encoding is performed in both time (two transmission intervals) and space domain (across two transmit antenna). The two rows and columns of S are orthogonal to each other and the code matrix is orthogonal.

$$(6)$$

Where is the identity matrix, this property enables the receiver to detect and by a simple linear signal processing operation.

Let us look at the receiver side now. Only one receiver antenna is assumed to be available. The channel at time  $t$  may be modelled by a complex multiplicative distortion

for transmit antenna one for transmit antenna two. Assuming that the fading is constant across two consecutive transmit periods of duration  $T$ , we can write

$$(7)$$

Where and ,  $i=1, 2$  are the amplitude gain and phase shift for the path from transmit antenna to the receive antenna. The received signal at the time and can then be expressed as

$$(8)$$

Where and are the received signal at time and , and are complex random variables representing receiver noise and interfaces. This can be written in matrix form as:

$$(9)$$

Where,  $h = [h_1, h_2]^T$  is the complex channel vector and  $n$  is the noise vector in the receiver.

### VI. SPACE-TIME BLOCK CODED SPATIAL MODULATION

Multiple-antenna systems that operate at high rates require simple yet effective space-time transmission schemes to handle the large traffic volume in real time. The basic idea of SM is an extension of two dimensional signal constellation (such as M-ary phase shift keying (M-PSK) and M-ary quadrature amplitude modulation (M-QAM), where M is the constellation size) to a third dimension which is the spatial (antenna) dimension. Therefore the information is conveyed not only by the phase/amplitude modulation (PAM) techniques, but also by the antenna indices. The error performance of SM scheme [5] is improved approximately in the amount of 4 db by the use of the optimal detector under conventional channel assumptions and that SM provides better error performance than V-BLAST. In this technique information is conveyed with an STBC matrix that is transmitted from the combination of the transmit antenna of the corresponding MIMO system. The Alamouti code is chosen as the target STBC to exploit. As a source of information, we consider not only the two complex information symbols embedded in Alamouti's code, but also indices of the two transmit antennas employed for the transmission of the Alamouti STBC.

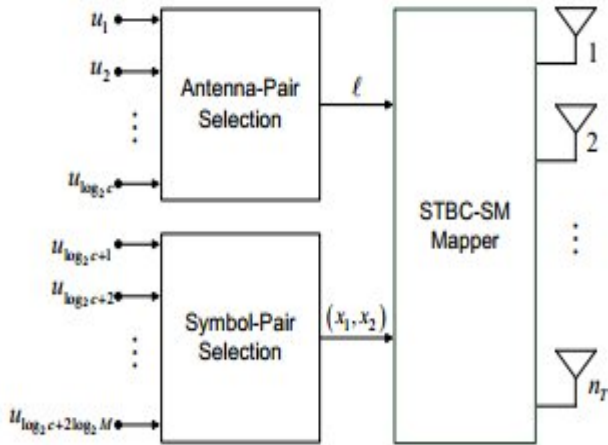

FIG 5 BLOCKS DIAGRAM OF STBC-SM TRANSMITTER

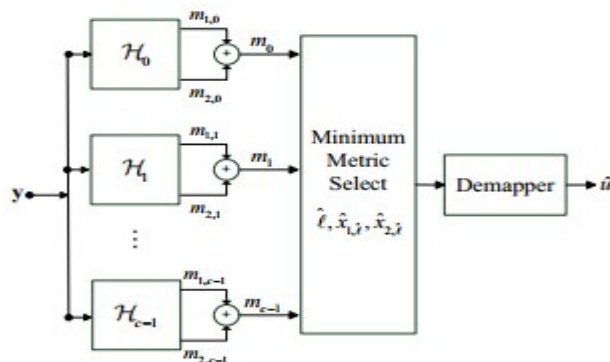

FIG 6 BLOCKS DIAGRAM OF STBC-SM

A general technique is presented in figure 3 and 4 for constructing the STBC-SM for any number of transmitting antenna. A low-complexity maximum likelihood ML detector is derived for the STBC-SM system, to decide the transmitted symbols as well as on the indices of the two transmitted antennas that are used in STBC transmission. It is observed [6] that STBC-SM scheme has significant performance advantage over the SM with an optimal decoder, due to its diversity advantage.

### VII. SIMULATION RESULTS

In this section, we present simulation results for STBC-SM system with different number of transmit and receive antenna. The bit-error-rate (BER) performance of these system was evaluated for various spectral efficiencies as a function of the average SNR per receive antenna. All performance comparisons are made for a SNR of the range from 0 to 20 db.

(A) This graph is plotted for the STBC-1x2, STBC-1x4, STBC 2x1 and STBC-2x2 antennas respectively. This system is designed for a packet size of 1000 bits, using QPSK modulation in Rayleigh fading environment; total numbers of packets are 100 to be transmitted.

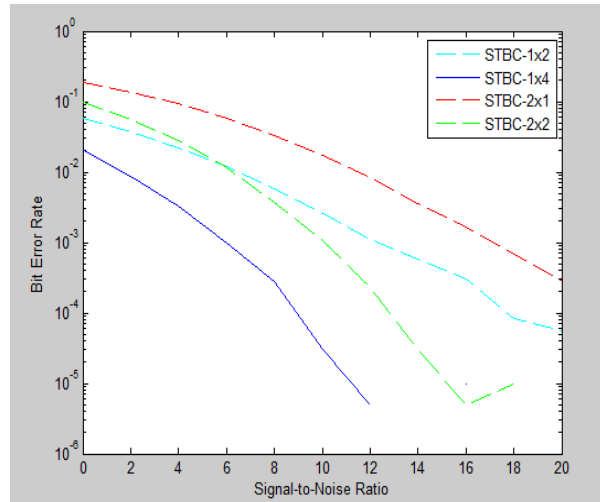
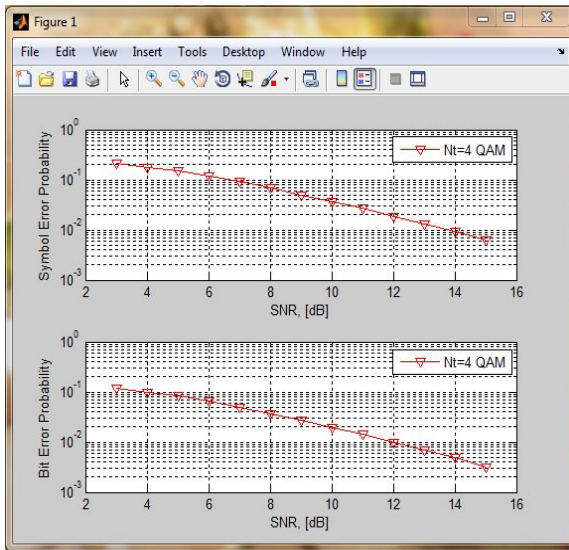

FIG 7 BER PERFORMANCE OF STBC FOR VARIOUS NUMBERS OF TRANSMITTER AND RECEIVER ANTENNAS

According to the above diagram, the STBC-1x4 and STBC-2x 2 systems have better performance than other two. In the STBC system with one transmit and four receive antennas, the maximum value of BER is  $10^{-1.8}$  for the initial value of SNR (SNR=0). The value of BER decreases to  $10^{-5.4}$  when SNR=12 db.

(B) The below graph shows the BER and SER performance for four transmit antennas using QAM modulation.

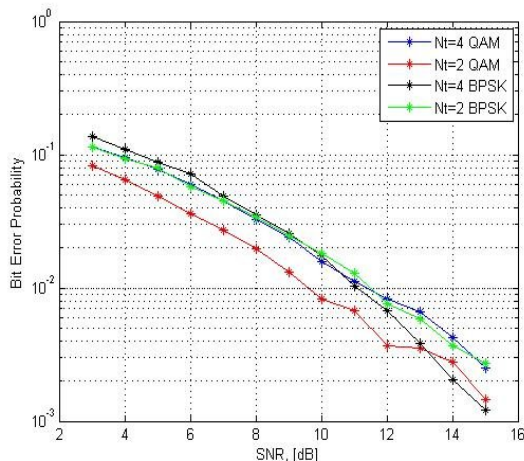



**FIG 8 BER AND SER FOR QAM**

As we can see in the graph that SER is decreasing with the increase in SNR. SER is  $10^{-1.0}$  when SNR=4 db. It decreases to  $10^{-2.5}$  when SNR=16 db. In the case of BER, it also decreases exponentially with the increases in SNR. BER=  $10^{-1.3}$  for SNR=4 db. It decreases to  $10^{-2.9}$  when the SNR=16 db.

(C) Bit-Error-Rate (BER) performances are given here for various antenna numbers for QAM and BPSK modulation schemes. QAM and BPSK give the better performance than other two.



**FIG 9 BER PERFORMANCE FOR DIFFERENT ANTENNAS USING QAM AND BPSK MODULATION SCHEMES**

To understand the graph, a table is given here. QAM gives the better result than others. BPSK also has

approximately good result. The values of BER according to SNR values are given in the table.

SIGNAL-TO-NOISE RATIO (SNR)	QAM	QAM	BPSK	BPSK
3db	$10^{-0.9}$	$10^{-1.2}$	$10^{-0.96}$	$10^{-0.97}$
4db	$10^{-1.1}$	$10^{-1.5}$	$10^{-0.99}$	$10^{-1.1}$
6db	$10^{-1.4}$	$10^{-1.7}$	$10^{-1.3}$	$10^{-1.4}$
8db	$10^{-1.6}$	$10^{-1.8}$	$10^{-1.63}$	$10^{-1.8}$
10db	$10^{-1.9}$	$10^{-2.2}$	$10^{-1.91}$	$10^{-1.91}$
12db	$10^{-2.2}$	$10^{-2.6}$	$10^{-2.4}$	$10^{-2.2}$
14db	$10^{-2.6}$	$10^{-2.7}$	$10^{-2.9}$	$10^{-2.5}$
15db	$10^{-2.7}$	$10^{-2.94}$	$10^{-2.98}$	$10^{-2.71}$

**TABLE I COMPARISON OF DIFFERENT ANTENNA USING DIFFERENT MODULATION SCHEMES WITH RESPECT TO BER**

The above diagram shows the symbol error probability according to SNR. QAM and BPSK have the minimum symbol error probability than other two. SER has minimum value  $10^{-2.5}$  when SNR=16 db for QAM. BPSK has the minimum value  $10^{-2.6}$  when SNR=16 db.

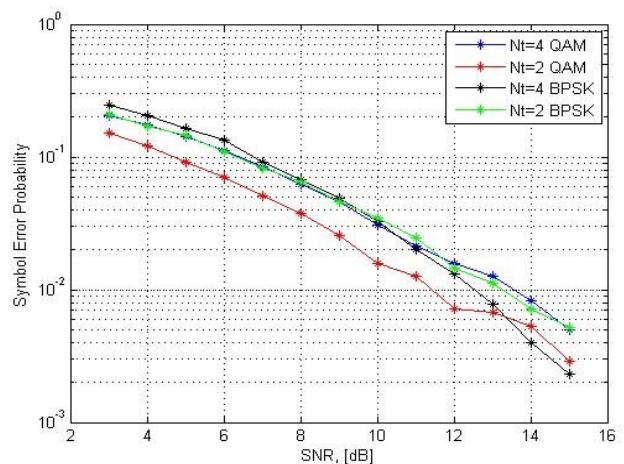

**FIG 10 SER PERFORMANCE USING DIFFERENT MODULATION SCHEMES**

To understand the variations in symbol error probability, a table is given here. All the values of SER with their respective SNR are given in the table. From here, we can easily identify the performance and changes of the values.



Signal-To-Noise Ratio (SNR)	QAM	QAM	BPSK	BPSK
3db	$10^{-0.9}$	$10^{-0.94}$	$10^{-0.83}$	$10^{-0.9}$
4db	$10^{-0.92}$	$10^{-0.99}$	$10^{-0.9}$	$10^{-0.92}$
6db	$10^{-0.99}$	$10^{-1.3}$	$10^{-0.96}$	$10^{-0.99}$
8db	$10^{-1.5}$	$10^{-1.7}$	$10^{-1.3}$	$10^{-1.3}$
10db	$10^{-1.8}$	$10^{-1.93}$	$10^{-1.8}$	$10^{-1.72}$
12db	$10^{-1.96}$	$10^{-2.3}$	$10^{-1.96}$	$10^{-1.95}$
14db	$10^{-2.3}$	$10^{-2.5}$	$10^{-2.6}$	$10^{-2.3}$
16db	$10^{-2.5}$	$10^{-2.8}$	$10^{-2.87}$	$10^{-2.6}$

**Table Comparison of Different Antennas Using Different Modulation Schemes With respect to SER**

### VIII. CONCLUSION

In this dissertation, a new modulation/coding concept are discussed, which is called Spatially-Modulated STBC. Some simulations are performed here to check the performance of the system. Concepts and advantages of Spatial Modulation and Space-Time Block Codes (STBCs) are applied on the system to achieve transmit-diversity and high spectral efficiency which exploit the location specific property of the wireless channel as an additional dimension for data transmission. This dissertation is devoted to Spatial Modulation (SM) and Space-Time Block Codes (STBCs) for Multiple-Input Multiple-Output (MIMO) system. The most prominent space-time block-codes are Orthogonal STBCs (OSTBCs) and most popular OSTBC is Alamouti code.

### IX. REFERENCES

1. J. Mietzner, R. Schober, L. Lampe, W. H. Gerstacker, and P. A. Hoeher, "Multiple-antenna techniques for wireless communications – A comprehensive literature survey", IEEE Commun. Surveys Tuts., vol. 11, pp. 87–105, 2nd quarter 2009.
2. Y. Yang and B. Jiao, "Information-guided channel-hopping for high data rate wireless communication", IEEE Commun. Lett., vol. 12, pp. 225–227, Apr. 2008.
3. T. L. Marzetta and B. M. Hochwald, "Capacity of a mobile multiple-antenna communication link in Rayleigh flat fading" IEEE Trans. Inform. Theory, vol.45, pp. 139-157, Jan. 1999.
4. I. E. Telatar, "Capacity of multi-antenna Gaussian channels," AT&T Bell Labs, Internal Tech. Memo, 1995. See also, European Trans. Telecommun. vol. 10,no. 6, pp. 585-595, 1999.
5. M. Di Renzo and H. Haas, "Improving the performance of space shift keying (SSK) modulation via opportunistic power allocation", IEEE Commun. Lett., vol. 14, no. 6, pp. 500–502, June 2010.
6. V. Tarokh, H. Jafarkhani, and A.R. Calderbank, "Space-time Block Codes from Orthogonal Designs," IEEE Transactions on Information Theory, Vol. 45, No. 5, pp. 1456-1467, July 1999.

7. IEEE TRANSACTIONS ON COMMUNICATIONS, VOL. 59, NO. 3, MARCH 2011 823 'Space-Time Block Coded Spatial Modulation' Ertuğrul Ba,sar, Student Member, IEEE, Ümit Aygölu, Member, IEEE, Erdal Panayırçı, Fellow, IEEE and H. Vincent Poor, Fellow, IEEE.

### BIOGRAPHIES

**Rahul Saxena** has completed his B.E. in electronics & communication engineering in 2010 from SRITS Datia (RGPV University Bhopal, (M.P.) India. He is pursuing his M.E. in digital communication from IPS Academy, Indore, India. At present he is in 4<sup>th</sup> and final semester of M.E.

**Prof. Rupesh Dubey** is working as an Associate prof. and head of the department (Electronics & Communication) IPS Academy, Indore (M.P.) India. He has received his B.E. and M.E. degree in electronics & communication engineering. He has more than ten years of experience as associate prof. and head of the department. He has published many papers in various reputed journals, national and international conferences.

**Prof. Poonam Lilhare** is working as an Asst. Prof (electronics & communication) in IPS Academy, Indore (M.P.) India. She has received her B.E. and M.E. degree in Electronics & communication engineering. She has more than five years of experience as Asst. Prof.