

Simulation and Implementation of Two-Quadrant Operation of Mains Operated DC Drive System

Ramyasree P R¹, Dr. R. Sankaran²

Research Scholar, EEE, SASTRA University, Thanjavur, India¹

Professor, EEE, SASTRA University, Thanjavur, India²

Abstract: This paper is concerned with the 2-quadrant operation of a DC shunt machine operated from AC mains, focusing on the control circuits for regeneration of power. It covers modelling, simulation and hardware implementation of the motoring and generating modes on a 3.7 kW 220V 1500 RPM DC shunt machine coupled to a cage induction motor. An IGBT based full bridge power electronics module works as a converter or inverter for realizing the 2 quadrants, where the voltage polarity remains the same, but the current direction gets reversed. Simulation and experimental results covering the 2 modes of operation are presented

Keywords: DC Machine, 2-quadrant operation, regeneration, IGBT inverter

I. INTRODUCTION

In many industrial drive applications where there is frequent starting and stopping/idling, it is desirable to adopt a regeneration strategy in the context of an active load, for energy conservation. When the mechanical operation is confined to a single direction of rotation, the above translates into the 2-quadrant operation, which can be implemented on a mains-fed DC shunt machine. The power interface between the AC supply and the DC machine is an IGBT based full bridge circuit, which operates as rectifier through the built-in reverse diodes[1]. The same power module is made to work as a PWM inverter for regeneration by appropriate trigger and gate driver circuits. This paper aims at the design, simulation and fabrication of the required power and control circuits. The DC machine is modeled as a subsystem, which can operate as a motor or a generator based upon the drive environment, mode of the power module and control signals. These aspects of the 2-quadrant operation of the overall system are discussed and results are presented.

II. CIRCUIT DIAGRAM

A. Power Circuit

Fig. 1 shows the power circuit consisting of the IGBT bridge module, the separately excited DC shunt machine and the coupled 3-phase induction motor. The DC machine can operate as a motor or generator depending on the relative magnitudes of the applied voltage V and the EMF E across

the armature and as facilitated by the converter or inverter mode of the IGBT bridge circuit. While the motor operation in quadrant 1 does not require and control or trigger action, a fairly complex control and driver circuit is required for the regeneration mode in quadrant 2 as explained in Section B.

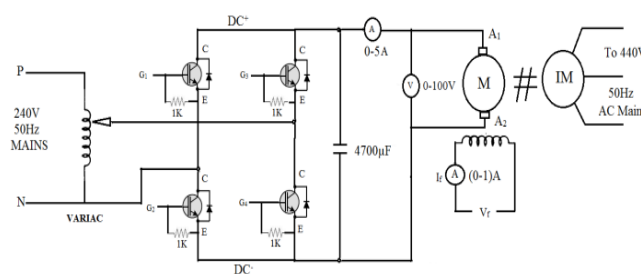

Fig. 1. Power circuit

First of all, the semiconductor devices in the power circuit have to carry bi-directional currents corresponding to rectifier and inverter operations[2]. Hence an IGBT based bridge circuit is employed for handling the power flow between the AC mains and DC machine. The above bridge circuit operates as a converter in Quadrant 1 through the freewheeling, anti-parallel built-in diodes. The same circuit operates as an inverter in Quadrant-2, where the IGBT gates are triggered in a PWM manner [3]. The conditions to be satisfied for operation in parallel with mains are equality of frequencies and voltages along with close matching of voltage waveforms, apart from a leading phase angle at the inverter side for reverse power flow[4].

B. Control Circuit

The full control circuit is shown in Fig.2 and implements the following functions.

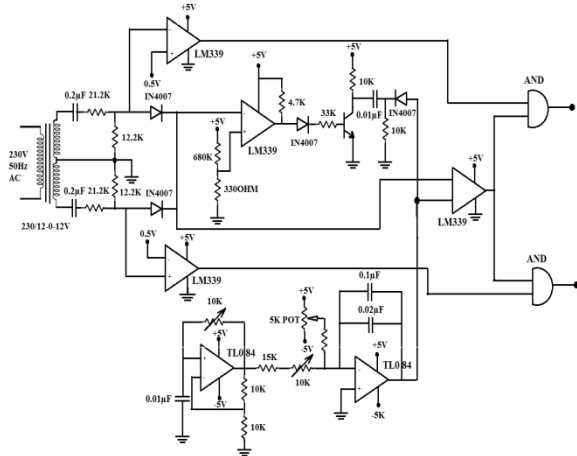

Fig 2. Overall control circuit

1. Phase Advancing Circuit for Reference Sine Wave.
2. Triangular Wave Generation at 1900 Hz.
3. Synchronization of Triangular Wave with Mains
4. Dead Time Generation
5. Generation of Pulse Width Modulation (PWM) Signals
6. Routing of PWM Signals for Diagonal Triggering
7. Generation of Four Channels of Driver Circuit

The above are realized first in simulation and then fabricated using IC based design. The major I.C's are TL 084 OPAMP, LM 339 Quad Comparator and IR2110 IGBT driver. A pair of PWM signals with appropriate routing control and dead time are generated to trigger the IGBTs of the bridge circuit diagonal-wise in a complementary manner so as to generate a bi-polar PWM output waveform[5], [6] .

III. SIMULATION OF 2-QUADRANT OPERATION

The simulation schematic for the 2-Quadrant operation of the DC machine is shown in Fig. 3. It consists of the shunt motor model, IGBT based full bridge circuit and the AC mains.

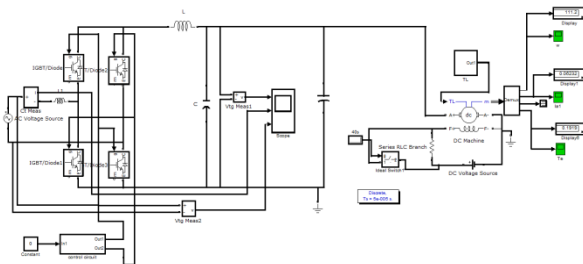

Fig.3 Simulation circuit for 2-quadrant operation

A. Motor Operation

Here the separately excited field current is set at the ratted value of 0.72A, and the 50Hz AC input voltage is set for terminal voltage of the DC motor to be at the rated value. The simulation results for the normal motor operation at a load torque of 6.8N-m are shown in Figs. 4-6 covering the motor speed, armature current and electromagnetic torque. These characteristics confirm the normal operation of the DC motor fed from a full wave rectified AC supply.

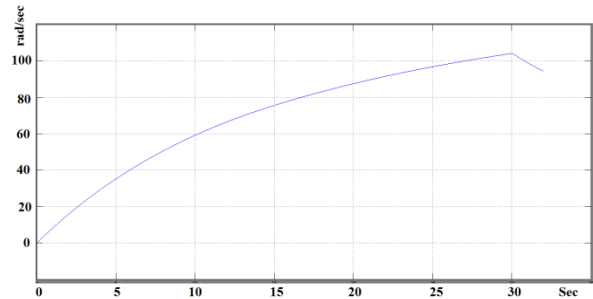

Fig.4 Transient variation of speed

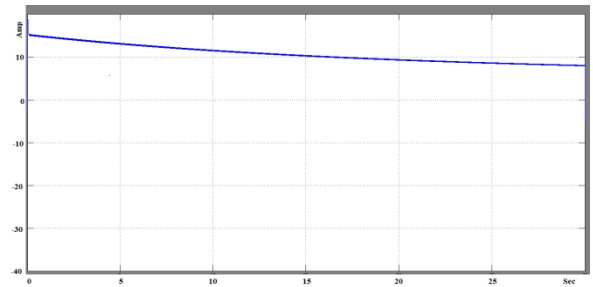

Fig.5 Transient variation of armature current

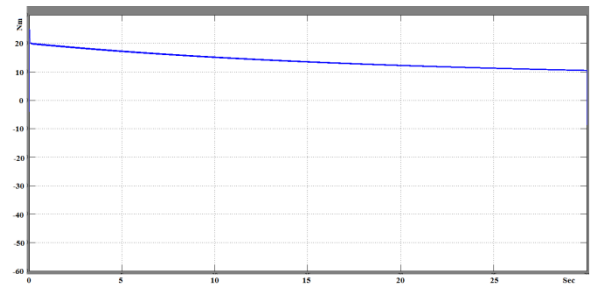

Fig.6 Simulation result of electromagnetic torque

B. Regeneration Operation

Here the full control circuit covering the reference sine wave, high frequency triangular wave, PWM generation and gate driver circuits are put into operation. Simulation of the full power circuit is now carried out, where the machine



starts as a DC motor from mains and is subsequently controlled to regenerate the rotational energy back to the mains. For illustrating the process, the coupled set runs as a motor for 30seconds, and picks up nearly the rated speed. At time $t = 30s$, the load torque is removed and the field current is increased by about 40% to facilitate the regeneration. Simultaneously the 4 IGBT's are triggered in a pair-wise diagonal manner, which produces a PWM output at 50Hz fundamental frequency. The simulation results covering the full transient variation of speed, armature current and electromagnetic torque covering both motor and generator actions are shown in Figs.7 to 9.

IV. EXPERIMENTAL SETUP FOR MOTOR OPERATION

The experimental setup is the same as in Fig. 1 and a set of load tests were conducted for determining the characteristics of the machine as a motor where the armature voltage was varied over a range, with specific settings of the field current. These tests were used for determining the friction and windage loss coefficients. The experimental performance characteristics of the motor are given in Figs.10 to 13, where P_e indicates power in the armature circuit.

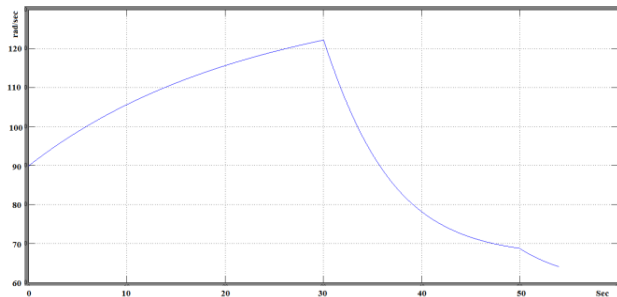

Fig.7 Transient variation of speed during regeneration

Figs. 7 to 9 indicate the transient fall of speed beyond 30s, accompanied by reversal of armature current and electromagnetic torque during $30 < t < 50$ sec. which indicate regeneration in Quadrant 2.

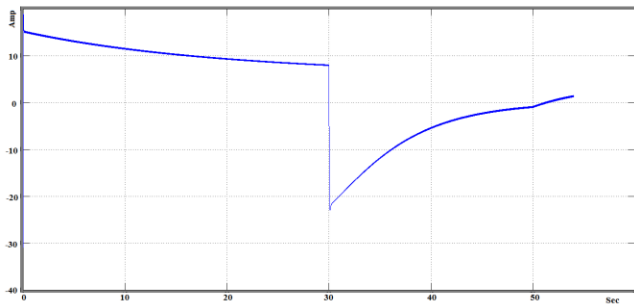

Fig.8 Transient variation of armature current during regeneration

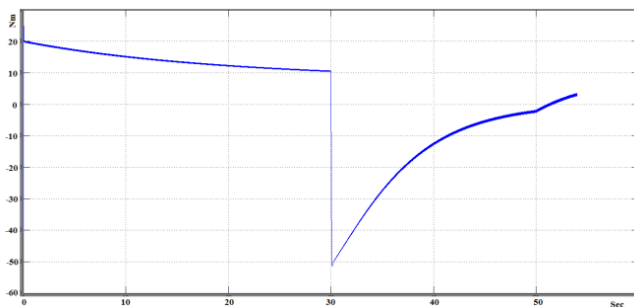

Fig.9 Simulation result of electromagnetic torque during regeneration

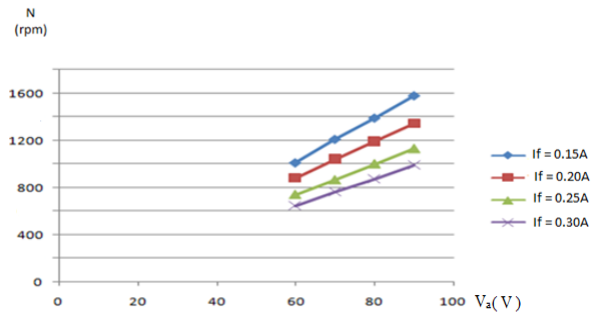

Fig.10 Variation of N Vs V_a (motor)

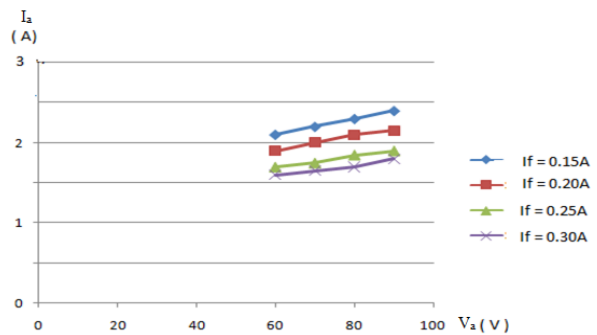

Fig.11 Variation of I_a Vs V_a (motor)

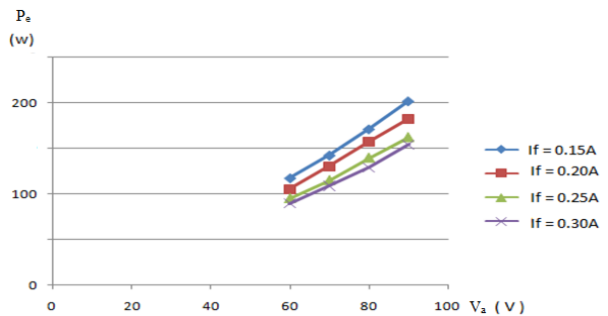

Fig.12 Variation of P_e Vs V_a (motor)

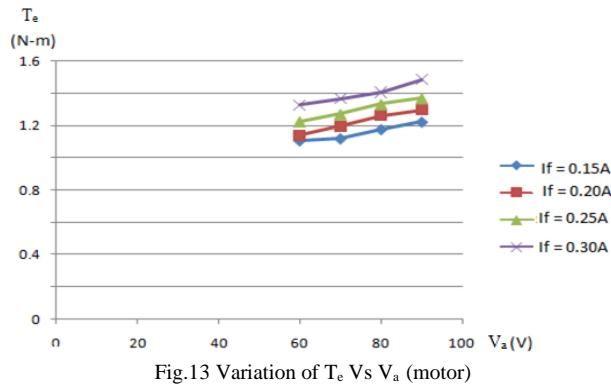

Fig.13 Variation of T_c Vs V_a (motor)

V. EXPERIMENTAL SETUP FOR REGENERATION

The power circuit for regeneration is shown in Fig.14. The full control circuit shown in Fig 2 is interconnected with the above at the (reference) sensing stage and the gate triggering interface. The reference sine wave is derived from the AC supply with a phase lead of about 30° . While the simulation results actually indicate a short time regeneration behaviour, it is found desirable to test the fabricated power and control circuits for sustained regeneration run. Accordingly the prime mover is run near the rated speed and the field excitation of the DC generator adjusted for reverse power flow at a convenient DC voltage of about 180 V.

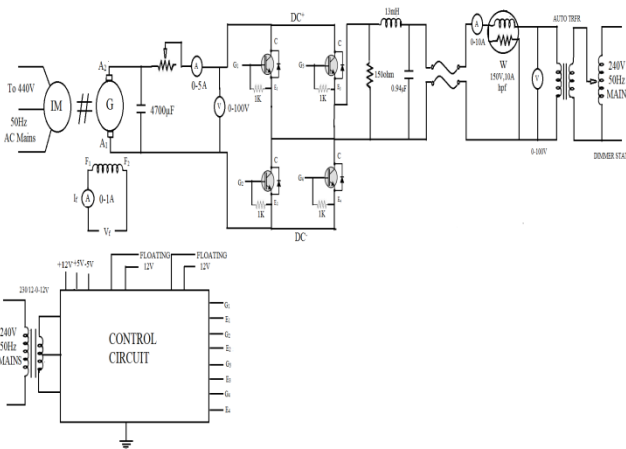

Fig.14 Experimental setup for regeneration

Incidentally, this experimental procedure brings out the issues involved in paralleling a PWM inverter with mains, like synchronization of trigger signals, phase lead requirement and wave shape, similar to a grid connected solar system[7] [8]. The bi-polar PWM output of the inverter is passed through a low pass filter with $L = 12\text{ mH}$ and $C = 0.94\mu\text{F}$ for obtaining a near sine wave. Fig.15 shows the photograph of the full experimental set up



Fig. 15 Experimental Setup

VI. REGENERATION RESULTS

Reverse power flow is achieved by paralleling of the inverter output with mains and is done by adjusting the two voltages to be nearly equal, at an AC voltage level of about 220V (peak value) through a pair of fuse switches. Figs 16 and 17 show the above waveforms before paralleling and afterwards. The performance of the regeneration scheme are obtained the plotting the variation of the AC side

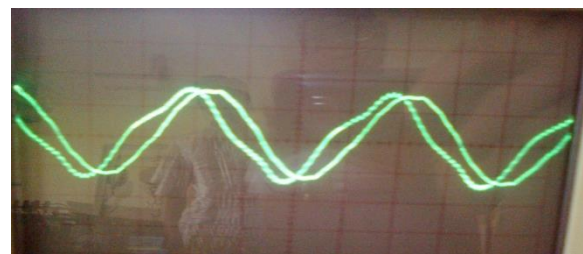

Fig.16 CRO Result Before Paralleling

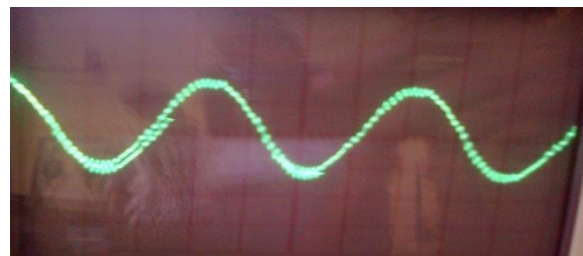

Fig.17 CRO Output After Paralleling

current and power flow into the mains with respect to the field current I_f , as shown in Figs 18 and 19.

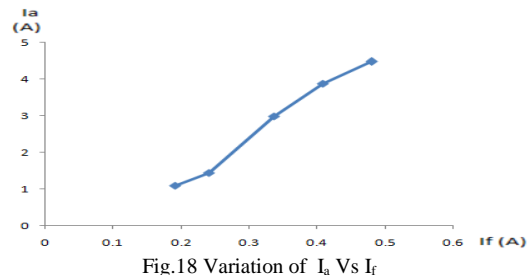

Fig.18 Variation of I_a Vs I_f

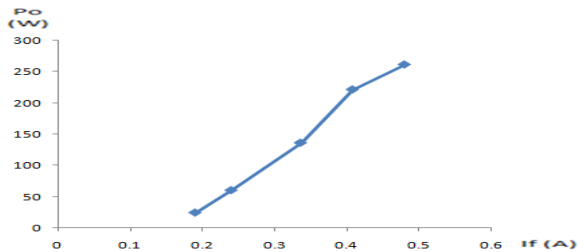

Fig.19 Variation of P_o Vs I_f

VII. CONCLUSION

This paper establishes the principles and feasibility of implementation of the 2-quadrant operation of a mains-fed DC machine. The simulation and experimental results confirm the objective of regeneration in a practical situation. An extension of the work with the DC machine fed from a 3-phase source of power is considered attractive.

REFERENCES

- [1] P. Jain, D. Vincenti and H. Jin: "An Optimized Single-phase AC Power Supply with DC Bus Synchronization" 1996 IEEE Xplore.
- [2] Bor-Ren Lin, Chien-Lan Huang "Interleaved Three-Level PWM Zero Voltage Switching Converter" in International Review on Electrical Engineering, Vol. 5. n. 2, pp. 347-355 March 2010.
- [3] Ahmad M. Al-Kandari and Tamer H. Abdelhamid: "A Sinusoidal PWM Control For Four-Quadrant Single-phase Drive System" IEEE,2000 Xplore.
- [4] B.-R. Lin and T.-S. Hwang: "Single Phase Rectifier With High Power Factor In Continuous and Discontinuous Conduction Mode" IEEE Catalog Number: 95TH8081
- [5] Tamer H Abdelhamid "Performance of Single-phase DC Drive System Controlled by Uniform PWM Full-Bridge DC-DC Converter", Mediterranean Electrotechnical Conference, MELeCon 2000, Vol. III 0-7803-6290-x/00/\$10.000 2000 IEEE.
- [6] Narong Aphiratsakun, Sanjiva Rao Bhaganagarapu and Kittiphan Techakittiroj Implementation of a Single-phase Unipolar Inverter Using DSP TMS320F241: AU J.T. 8(4): 191-195 (Apr. 2005)
- [7] K.N.Dinesh Babu, R.Ramaprabha & V.Rajini "Mathematical Modelling and Simulation of Grid Connected Solar Photovoltaic System" International Journal of Electrical and Electronics Engineering (IJEET) ISSN (PRINT): 2231 – 5284, Vol-2, Iss-1, 2012
- [8] E. Robles, S. Ceballos, J. Pou, F. Salcedo, and M. Santos, "Tuning of controllers in grid-connected multilevel converters," in International Review on Modelling and Simulations (IREMOS), Vol. 5, No. 3, June 2012, pp. 1165-1174.

BIOGRAPHY



Ramyasree P R obtained the B Tech degree in EEE in 2011 from Mahatma Gandhi University College of Engineering Thodupuzha in Kerala, India. She joined the M Tech in Power Electronics and Drives course in the SASTRA University Thanjavur, Tamilnadu, India in the same year and completed the course in June 2013. Her areas of interests are Power Electronics and Drives and Control circuits.



Dr. R. Sankaran obtained M.Tech in Control Systems from I.I.T., Kanpur in 1972 and Ph.D. in Electrical Engg., from the College of Engineering, Trivandrum (University of Kerala) in 1980. He is currently working as professor in EEE Department of SASTRA University, Thanjavur, India. His current areas of Interest are Power Electronics and Drives, Control Systems and Micro controllers. He is Senior Member of the institution of Engineers, India.