



# Double Flying Capacitor Multi cell Converter based on Modified Phase Shifted Pulse width Modulation

Neema Rasheed<sup>1</sup>, Saritha M<sup>2</sup>

PG Student, Department of EEE, Govt. College of Engineering Kannur, Kannur, India<sup>1</sup>

Associate Professor, Department of EEE, Govt. College of Engineering Kannur, Kannur, India<sup>2</sup>

**Abstract:** The multilevel converters receive wide acceptance in industry and energy systems because they enable the design of medium and high voltage systems with excellent output voltage quality. Among the different topologies for multilevel converters, multicell converters feature the highest degree of modularity and the lowest expense for redundancy due to the large number of cells they have, as well as the lowest harmonic content due to the large number of output voltage levels they produce. In this paper a Four-cell Nine-level DFCM Converter is explained. The main advantages of this converter, in comparison with FCM, are doubling the rms and the number of output voltage levels and improving the output voltage frequency spectrum. Moreover the number of high frequency switches, flying capacitors and input dc voltage sources are reduced by 50%. This converter is controlled by modified phase-shifted pulsewidth modulation technique. The Four-cell nine-level DFCM circuit is simulated in MATLAB software and simulation results are presented to validate the effectiveness and advantages of the respective configuration and the THD for the converter was found to be less than 1% (which meets the harmonic standards of IEEE).

**Keywords:** Flying capacitor multicell (FCM) converter, phase shifted pulsewidth modulation (PSPWM), natural balance, stacked multicell (SM) converter).

## I. INTRODUCTION

The multilevel converters have been continuously developed in recent years due to the necessity of increase in power level of industrial applications, especially high-power applications, such as high-power ac motor drives, active power filters, reactive power compensation, and FACTS devices. The main reason is the capability of these topologies to handle a large value of voltage/power in the range. The multilevel converters are finding increased attention in industry as one of the preferred choices of electronic power conversion for high-power applications. They have successfully made their way into the industry and therefore can be considered a mature and proven technology. The multilevel converters receive wide acceptance in industry and energy systems because they enable the design of medium and high voltage systems with excellent output voltage quality. Compared to the two-level voltage source converter, the simple realization of redundancy, low filter expense, and the reduction of power semiconductor losses and common mode voltages are important additional benefits.

Among the different topologies for multilevel converters [1]-[2], multicell converters feature the highest degree of modularity and the lowest expense for redundancy due to the large number of cells they have, as well as the lowest harmonic content due to the large number of output voltage levels they produce. The large number of cells substantially increases the requirement of the converter controller, but each cell offers a simple structure, reducing the manufacturing costs. Currently multicell converters are used in applications like medium voltage drives (MVD), active filters, integration of renewable energy sources to the electrical grid, and in high-voltage dc (HVDC) transmission systems [3]. A number of these multicell converters are cascaded to form a Modular Multilevel Converters. The modular multilevel converter (MMC) has become the most attractive multilevel converter topology for medium/high-power applications, specifically for voltage sourced converter high-voltage direct current (VSC-HVDC) transmission systems. The term multilevel starts with the three-level converter. By increasing the number of levels in the converter, the output voltage has more steps generating a staircase waveform, which has a reduced harmonic distortion. However, a high number of levels increases the control complexity and introduces voltage imbalance problems. Different cells and ways to interconnect them generate many topologies. The efficiency of the cells can be improved, replacing the standard cell by multilevel structures, such as Neutral point clamped, Cascaded H bridge or Flying capacitors etc. Nowadays, there exist three commercial voltage/current source multilevel power converters as a cost-effective solution for medium-voltage and high-power energy management fields. These include the neutral point clamped or diode-clamped converters, the cascaded H-bridge converters, and the flying capacitor (FC) or capacitor-clamped converters.



One of the most significant and promising structures of the multilevel converters is the FC multicell (FCM) converter and its subtopologies such as stacked multicell (SM). An  $m$ -level diode clamp converter typically consists of  $m-1$  capacitors on the dc bus and produces  $m$  levels of the phase voltage. Excessive clamping diodes are required when the number of the levels is high. It is difficult to do real power flow control for the individual converter. Moreover this topology requires high voltage rating for blocking diodes and have unequal device rating and capacitor voltage unbalance. In the case of flying capacitor multilevel converters, high-level systems are more difficult to package and more expensive with the required bulky capacitors. The inverter control will be very complicated and the switching frequency and switching losses will be high for real power transmission. For cascaded inverters [4] with separate dc sources, each cell is a structure based on an isolated voltage source, therefore, a bulky and complex multisecondary input transformer is required when only one dc voltage source is available. Therefore, it causes increase in the cost and size of the converter. It needs separate dc sources for real power conversions, and thus its applications are somewhat limited.

A  $2n$ -cell Flying Capacitor Multicell converter is composed of  $4n$  switches forming  $2n$ -commutation cells controlled with equal duty cycles and phase shifted of  $\pi/n$  and  $2n - 1$  flying capacitors with the same capacitance. As a result, the electrical stresses on each switch are reduced and more equally distributed as each switch must withstand  $E/n$  volts. The output voltage of  $2n$ -cell FCM converter has  $2n + 1$  level. Main advantages of a FCM converter over a CM (Cascaded multilevel) converter are that the FCM converter does not require a complex input transformer. An alternative topology based on the FCM converter is the SM converter [5], this structure uses an  $m \times n$  cells array to increase the number of output voltage levels. The main advantages of this configuration are that the number of combinations to obtain a desired voltage level is increased (redundancy), and the voltage ratings of capacitors and stored energy in the flying capacitors as well as the semiconductor losses are reduced. However, it requires the same number of capacitors and semiconductors in comparison with the equivalent FCM converter for the same number of output voltage levels. Two low-frequency switches are added to the conventional configuration of FCM converter and the new four-cell-nine-level converter, called DFCM converter is obtained (as shown in Fig 2). The main advantages of this converter, in comparison with FCM and SM converters, are doubling the rms of output voltage and the number of output voltage levels and cancelling the midpoint of dc source.

## II. DOUBLE FLYING CAPACITOR MULTICELL CONVERTERS

The flying-capacitor-based multicell converters are one of the most significant and promising structures of the multilevel converters and are particularly attractive due to advantage of natural capacitor voltage balancing process. This balancing can be observed when all cells of the flying-capacitor-based multicell converters operate with the same duty cycle and interleaved switching strategy such as phase-shifted pulse-width modulation (PS-PWM). The voltage balance of the FCs that ensures the safe operation of the flying-capacitor-based multicell converters is a concern of utmost importance in these topologies.

### A. Conventional Flying Capacitor Multicell Converter Configuration

A typical configuration of a conventional FCMC is shown in Fig 1, which is based on  $n$  cells which are connected in series to form required converter leg and can produce  $n+1$  levels of voltage with peak to- peak value of  $E$  at the output.

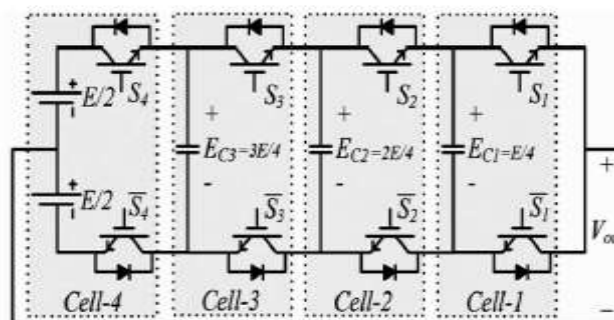

Fig 1. : 4-cell-5-level conventional FCMC producing the output voltage with peak-to peak value of  $E$

Each cell in FCMC [6]-[7] is made-up of one FC and a pair of power switches with complementary control signals. Due to the identical output current and switching frequency, the capacitance of FCs are of the same in order to obtain the same voltage ripple. However, FCs' dc voltage ratings are different and equal to  $E/n, 2E/n, \dots, (n-1)E/n$ . As a result, each power switch sustains just a fraction of dc-link voltage, i.e.,  $E/n$ . Redundant switching states in FC converters



permit the stabilization of voltage across the FCs at their requisite values. The commutation between the adjacent cells with their corresponding FCs charged to the required voltage values generates regularly stepped levels of chopped input voltage at the output side of these converters.

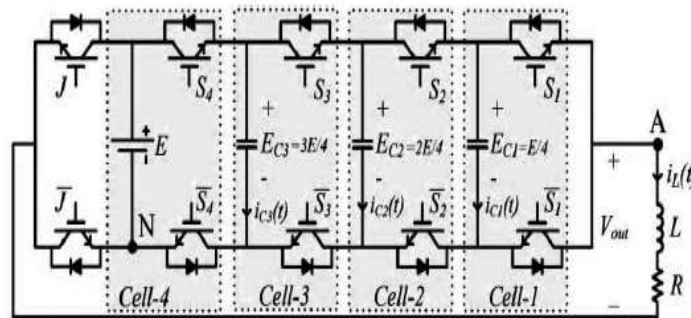

Fig 2. Four-cell-nine-level DFCM converter’s configuration

The main advantages of the proposed converter, in comparison with FCM and SM converters, are doubling the rms of output voltage and the number of output voltage levels and cancelling the midpoint of dc source. This progress is achieved by adding only two low-frequency switches to the conventional configuration of FCM converter, while the number of high frequency switches and capacitors, voltage ratings of capacitors and switches and the number of high-frequency switchings during a full cycle are kept constant. Also, the frequency spectrum of output voltage is improved and its THD is reduced significantly because of doubling the number of output voltage levels.

B. Control Strategies

Fig 3 shows the control strategy based on the PS-PWM, states of power switches and the output voltage of a 4-cell-five-level FCMC controlled by the PSC-PWM and operated with a modulation index equal to 0.8 (M= 0.8). To satisfy the natural voltage balancing of the FCs, a regular phase shift must be applied to the control signals which is shown in fig 3 for 4-cell-five-level FCMC controlled by the PSC-PWM switching technique and the phase shift between the carriers of adjacent cells is

$$\delta = 2\pi/n$$

where n is the number of cells.

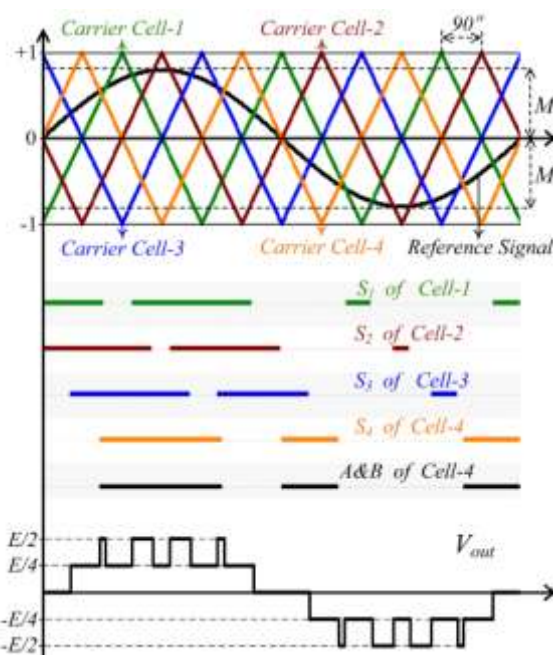

Fig 3. Switching pattern based on the PS-PWM, states of the power switches and switched output voltage of a 4-cell-5-level FCMC.



In the conventional configuration of FCM converter, maximum values of positive and negative peaks of output voltage are only half of the dc source voltage, i.e.,  $E/2$ , while in the studied DFCM converter, applying the switches  $J$  and  $J^*$ , makes it possible to obtain full value of the dc source voltage,  $E$  for positive and negative peaks of output voltage. This achievement causes to double the rms value of output voltage and the number of output voltage levels.

The power switch is ON when its state is 1 and is OFF when its state is 0. State of power switches of the 4-cell-five-level FCMC are also illustrated in Table1.

TABLE I STATE OF POWER SWITCHES OF THE 4-CELL 5-LEVEL FCMC

Output Voltage Level	State of Power Switches	Number of States
+0.5E	(1,1,1,1)	1
+0.25E	(1,1,1,0)(1,1,0,1) (1,0,1,1)(0,1,1,1)	4
0	(1,1,0,0)(1,0,0,1) (0,0,1,1)(1,0,1,0) (0,0,1,1)(0,1,0,1)	6
-0.25E	(1,0,0,0)(0,1,0,0)(0,0,1,0) (0,0,0,1)	4
-0.5E	(0,0,0,0)	1

The control strategy for a 4-cell 9-level DFCM Converter is shown in Fig 4. Here a modified Phase Shifted pulsewidth modulation technique [8] is used.

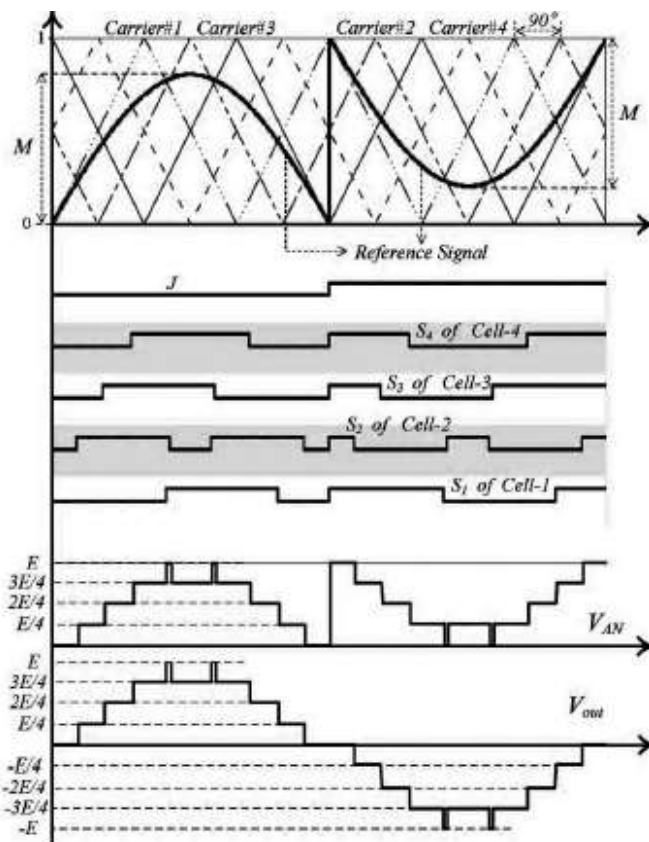

Fig 4. Control Strategy for 4-cell 9-level DFCM Converter

The progress of doubling the rms of output voltage and the number of output voltage levels in the proposed DFCM converter makes it possible to decrease the number of flying capacitors, high-frequency switches and input dc voltage sources by 50% in comparison with FCM and SM converters. The switching states for a 4-cell 9-level DFCM Converter is illustrated in table II.



TABLE II SWITCHING STATES OF A 4-CELL 9-LEVEL DFCM CONVERTER

Output Voltage Level	State		No. of states
	J	( $S_4, S_3, S_2, S_1$ )	
+E	0	(1,1,1,1)	1
$+\frac{3}{4}E$	0	(1,1,1,0), (1,1,0,1), (1,0,1,1), (0,1,1,1)	4
$+\frac{2}{4}E$	0	(1,1,0,0), (1,0,0,1), (0,0,1,1), (0,1,1,0)	4
$+\frac{1}{4}E$	0	(1,0,0,0), (0,1,0,0), (0,0,1,0), (0,0,0,1)	4
0	0	(0,0,0,0)	2
	1	(1,1,1,1)	
$-\frac{1}{4}E$	1	(0,1,1,1), (1,0,1,1), (1,1,0,1), (1,1,1,0)	4
$-\frac{2}{4}E$	1	(1,1,0,0), (1,0,0,1), (0,0,1,1), (0,1,1,0)	4
$-\frac{3}{4}E$	1	(0,0,0,1), (0,0,1,0), (0,1,0,0), (1,0,0,0)	4
-E	1	(0,0,0,0)	1

III. SIMULATION RESULTS

A basic Four-cell Five-level FCM converter is initially simulated and later on a Four-cell nine-level DFCM converter is simulated. The simulation Parameters are chosen as shown in Table III.

TABLE III

Parameters	Values
DC Voltage (E)	200V
Internal Flying Capacitors (C)	1mF
Switching Frequency	700Hz
Resistive Load	500Ohms
Resistive-Inductive Load	20 Ohms-50mH

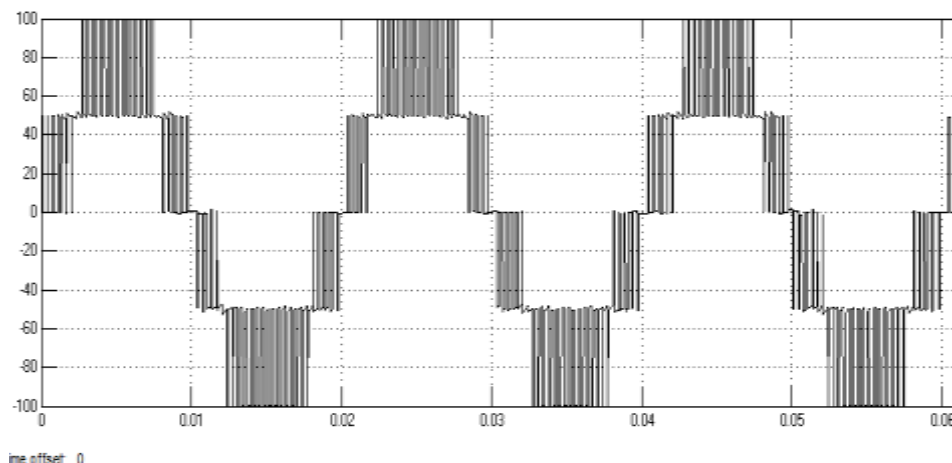

Fig 5 Output Voltage for a 4cell 5level FCM Converter



The four-cell-five-level FCM converter is controlled by PSPWM (fswitching = 700 Hz) and operated with a modulation index equal to 0.8 (M = 0.8). The converter load is resistive and the output voltage without RLC filter is shown in Fig 5. By using the above parameters simulation is being done and five level output voltage is obtained with output voltage levels at +100V,+50V,0V,-50V and -100V respectively as shown in Fig 5.

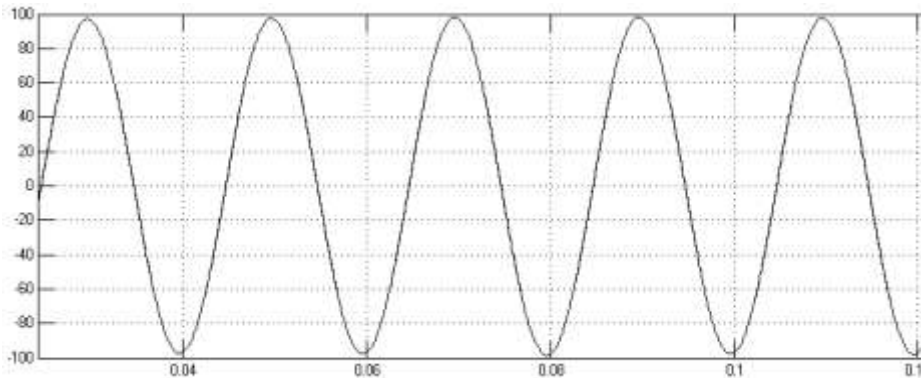

Fig 6. Filtered output voltage for a Four Cell Five Level FCM Converter

The simulated five level converter has a voltage THD of 14.83 % (as shown in Fig 7). The rms values of output voltage is 69.78V. Here RLC filter is used to obtain a sinusoidal output voltage. The filtered output voltage for the 4-cell 5-level FCM Converter is shown in Fig 6.

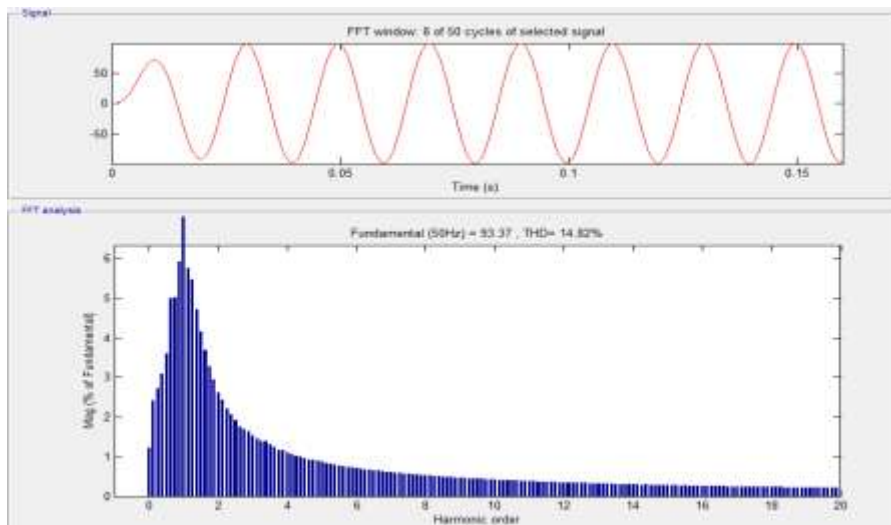

Fig 7. FFT Analysis for Five level FCM Converter

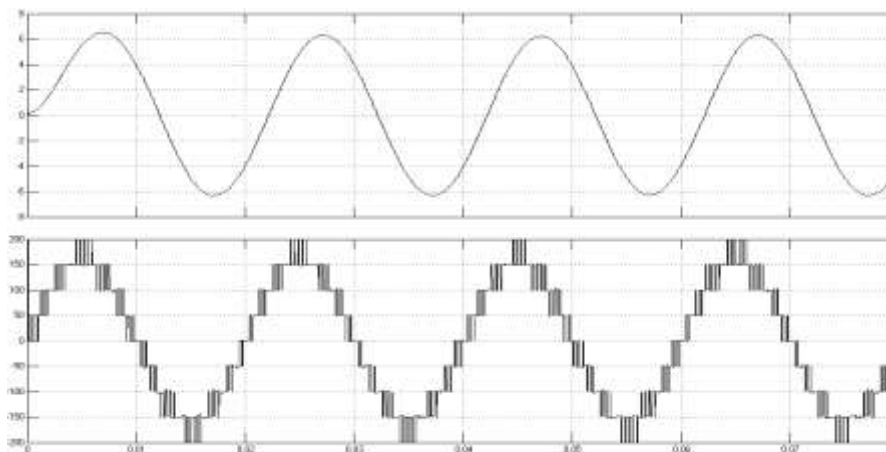

Fig 8 Output current and Output voltage for a Four cell nine level DFCM Converter



From the simulation of a DFCM Converter it is found that the rms value of output voltage was doubled to 144.7V. Also, the frequency spectrum of output voltage is improved and its THD is reduced significantly because of doubling the number of output voltage levels. The DFCM is also simulated with modulation index  $M=0.8$  and modified phase shifted PWM Technique is employed. The load used is resistive-inductive load. The output waveform as well as the filtered output for a 4-cell 9-level DFCM Converter is shown in Fig 8 and Fig 9 respectively.

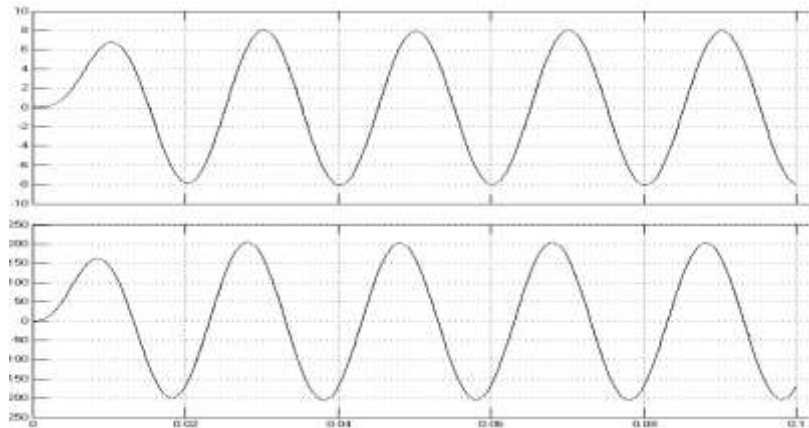

Fig 9. Filtered output voltage for a 4 cell 9 level DFCM Converter

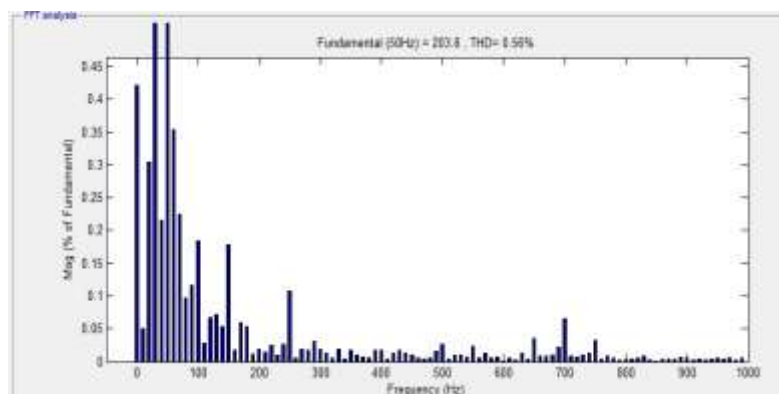

Fig 10. FFT Analysis for four cell nine level DFCM

The THD for the DFCM Converter is significantly reduced to 0.5% ( as per the IEEE Standards) as compared to conventional FCM topology which is shown in Fig 10.

#### IV.CONCLUSION

Multicell converters are suitable for high-power/high voltage applications and improve the output voltage/frequency spectrum. Here new configuration of the FCM converter called DFCM Converter (Double Flying Capacitor Multicell Converter) is explained. In comparison with FCM (Flying Capacitor Multicell) and SM (Stacked Multicell) converters, the main advantages of the proposed converter are doubling the rms of output voltage and the number of output voltage levels and cancelling the midpoint of dc source. Also, the frequency spectrum of the output voltage is improved and its THD is reduced significantly because of doubling the number of output voltage levels. This makes it possible to decrease the number of input dc voltage sources by 50% in comparison with CM (Cascaded Multicell), FCM and SM converters. Moreover, the self-balancing property of the FCM and SM converters, and transformerless operation are maintained in the proposed DFCM converter, in which the control strategy is based on the modified PSPWM. Here a 4cell 5level FCM Converter as well as a four cell nine level DFCM Converter is simulated to verify the performance and effectiveness of the respective converters.

#### REFERENCES

- [1] P. Lezana, J. Rodríguez, and D. A. Oyarzún, "Cascaded multilevel inverter with regeneration capability and reduced number of switches," IEEE Trans. Ind. Electron., vol. 55, no. 3, pp. 1059–1066, Mar. 2008.



- [2] T. A. Meynard, H. Foch, F. Forest, C. Turpin, F. Richardeau, L. Delmas, G. Gateau, and E. Lefeuvre, "Multicell converters: Derived topologies," IEEE Trans. Ind. Electron., vol. 49, no. 5, pp. 978–987, Oct. 2002
- [3] C. Haederli, P. Ladoux, T. Meynard, G. Gateau, and A. M. Lienhardt, "Neutral point control in multi level converters applying novel modulation schemes," in Proc. IEEE 37th Power Electron. Spec. Conf. (PESC 2006), Jun. 18–22, pp. 1–8.
- [4] P. Lezana, G. Ortiz, and J. Rodríguez, "Operation of regenerative cascade multicell converter under fault condition," in Proc. 11th Workshop Control Model. Power Electron. (COMPEL 2008), Aug. 17–20, pp. 1–6.
- [5] G. Gateau, T. A. Meynard, and H. Foch, "Stacked multicell converter (SMC): Properties and design," in Proc. IEEE PESC Meeting, 2001, pp. 1583–1588.
- [6] T. Meynard, A. M. Lienhardt, G. Gateau, C. Haederli, and P. Barbosa, "Flying capacitor MultiCell converters with reduced stored energy," in Proc. IEEE Int. Symp. Ind. Electron., Canada, Jul. 2006, pp. 914–918.
- [7] S. H. Hosseini, A. K. Sadigh, and A. Sharifi, "Estimation of flying capacitors voltages in multicell converters," in Proc. 6th Int. ECTI Conf., Thailand, May 2009, vol. 1, pp. 110–113.
- [8] C. Feng, J. Liang, and V. G. Agelidis, "Modified phase-shifted PWM control for flying capacitor multilevel converters," IEEE Trans. Power Electron., vol. 22, no. 1, pp. 178–185, Jan. 2007.
- [9] G. Gateau, M. Fadel, P. Maussion, R. Bensaid, and T. A. Meynard, "Multicell converters: Active control and observation of flying capacitor voltages," IEEE Trans. Ind. Electron., vol. 49, no. 5, pp. 998–1008, Oct. 2002.
- [10] J. Rodríguez, J. S. Lai, and F. Z. Peng, "Multilevel inverters: A survey of topologies, controls and applications," IEEE Trans. Ind. Electron. vol. 49, no. 4, pp. 724–738, Aug. 2002

### BIOGRAPHIES

**Neema Rasheed** received B.tech degree in Electrical and Electronics Engineering from University of Kerala, Kerala, India. Currently working towards M.tech degree under KTU at Government Collge of Engineering, Kannur.

**Dr. Saritha M**, Associate professor in Dept. of EEE in Government College of Engineering, Kannur. She received PhD from National Institute of Technology, Calicut, Kerala, India.