



Efficient Power Generation by Photo Voltaic System Based MPPT with Fuzzy Controller

Manish Bharat¹, Anupam Halder², Prashant Tyagi³, Md Zaid Khan⁴

Assistant Professor, Electrical & Electronics Engg, Sri Venkateshwara College of Engineering, Bangalore, India¹

BE, Electrical & Electronics Engineering, Sri Venkateshwara College of Engineering, Bangalore, India^{2,3,4}

Abstract: As the fears of climate change increase, the demands for devices that generate electricity that are environmentally friendly will steadily increase. Nowadays, solar energy has very significant in the fulfilment of power because of heavy demand and lower production. Solar energy, which is in the form of radiation, is received by the earth from the sun. The solar energy is a clean, everlasting and renewable energy source and does not cause pollution. This paper presents the way to improve the efficiency of grid connected solar PV module by using Maximum Power Point Tracking technology with Fuzzy logic controller.

Keywords: Renewable Energy, Grid Connected, PV Array, Fuzzy logic Controller, Maximum Power Point Tracking System, Improve Efficiency.

I. INTRODUCTION

In current scenario, the research and development work in the area of solar irradiance have made PVS popular and a feasible alternative resource and having effective solution regarding the environmental problems. Grid connected PVS gained more attention and popularity as the demand of electricity in day to day life is increasing rapidly due to modern civilization. There are two topology which are widely used to interface PVS to grid single stage and two stage PVS. In single stage PVS the grid tied inverter is required to control its parameters like output current, output voltage etc. and harmonics mitigation is done by using shunt active filters. Although, single stage remains cheaper but its computational complicity gets increases. A two stage PVS, having separate stages for controlling dc/dc converter by using MPPT algorithm and grid connected inverter by controlled pulses. This topology has less computational complicity. AFLC technique easily handles non linearities and is robust invariable environmental condition. Three phase three leg twelve pulse inverter is used in addition with RLC filter and its switching is control by controlling direct axis and quadrature axis voltage and current using discrete PI controller for maintaining synchronization with grid. The paper is categorized into following sections; Section II presents the system details (DC/DC boost converter, Adaptive Fuzzy Logic Control for maximum power point tracking and Voltage Source Inverter control). Model simulation and results are discussed in Section III and final conclusion has been made in Section V.

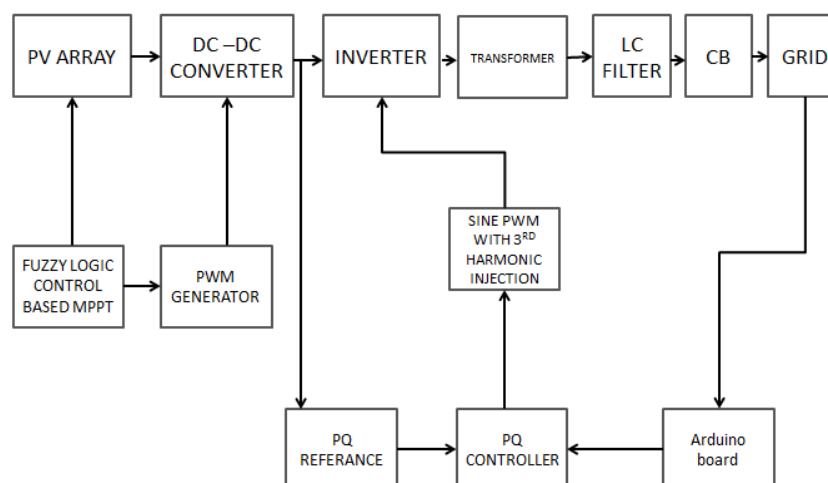

Fig1. Block diagram of grid connected MPPT system

II MODELLING OF PV ARRAY

The building block of PV arrays is the solar cell, which is basically a p-n junction that directly converts light energy into electricity. It has an equivalent circuit as shown figure. The current source I_{ph} represents the cell photo current; R_j is used to represent the non-linear impedance of the p-n junction; R_{sh} and R_s are used to represent the intrinsic series and shunt resistance of the cell respectively. Usually the value of R_{sh} is very large and that of R_s is very small, hence they may be neglected to simplify the analysis.

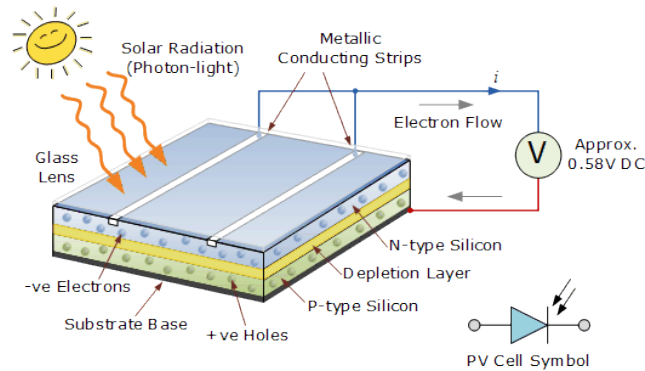

Fig. 3 Basic model of solar PV

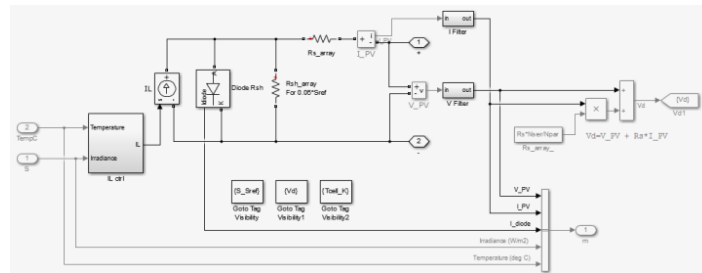

Fig. 4 Simulink model

III MAXIMUM POWER POINT TRACKING

The power output from the solar panel is a function of irradiation level and temperature. But for a given operating condition, we have a curve which gives the voltage level maintained by the panel for a particular value of current. This plot is known as the characteristics of the cell. From the characteristics plot, we will be able to derive the power output with respect to the output current. The operating point of any source sink mechanism is the intersection point of load line with the source characteristic plot. What we attempt here to do is change the load angle theta to intersect the characteristics at maximum power point. The PV characteristics and maximum power point is shown in figure (3).

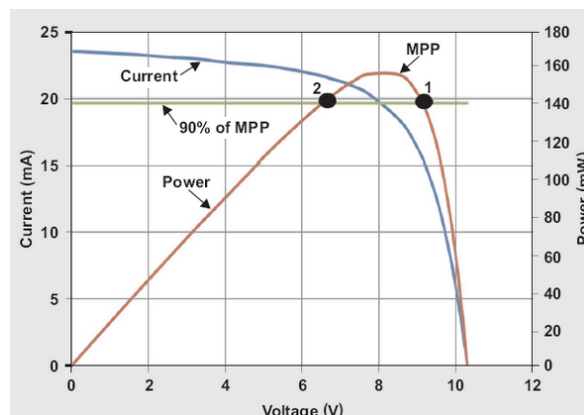

Fig 5 Maximum power point tracking



Photovoltaic modules have a very low conversion efficiency of around 15 percentage for the manufactured ones. Besides, due to the temperature, radiation and load variations, this efficiency can be highly reduced. In fact, the efficiency of any semiconductor device drops steeply with the temperature. In order to ensure that the photovoltaic modules always act supplying the maximum power as possible and dictated by ambient operating conditions, a specific circuit known as Maximum Power Point Tracker (MPPT) is employed. In most common applications, the MPPT is a DC-DC converter controlled through a strategy that allows imposing the photovoltaic module operation point on the Maximum Power Point (MPP) or close to it.

IV FUZZY LOGIC CONTROLLER

Due to developments in micro controller and DSP technologies, fuzzy logic control has received increased interest in MPPT applications. Fuzzy logic controllers have the advantages of working on systems with nonlinearities [5], not needing an accurate dynamic model and working with imprecise inputs. Fuzzy logic control is based on three stages [7]. The fuzzification stage converts input variables into linguistic variables based on a membership function as shown in Figure. In this case, there are seven fuzzy levels, which are NB (Negative Big), NM(Negative Medium), NS (Negative Small), ZE(zero), PS(Positive Small), PM(Positive Medium), and PB (Positive Big).As number of fuzzy levels increases, the accuracy . a and b are based on the range of values of the numerical variable in Figure 5. In the membership function, some specific fuzzy levels can be designed as unsymmetricalto make them more dominant, in other words to give them more importance. The error E and its variation (E) are inputs to the fuzzy logic-based MPPT controller. E and E can be calculated based on the user’s preferences.

E\CE	NB	NM	NS	NZ	ZE	PZ	PS	PM	PB
NB	ZE	ZE	ZE	PB	PB	PB	PB	PB	PB
NM	ZE	ZE	ZE	PM	PM	PM	PM	PM	PM
NS	ZE	ZE	ZE	PS	PS	PS	PS	PS	PS
NZ	PS	PM	ZE	ZE	ZE	ZE	ZE	NM	NS
ZE	PS	PM	ZE	ZE	ZE	ZE	ZE	NM	NS
PZ	NS	NM	ZE	ZE	ZE	ZE	ZE	PM	PS
PS	NS	NS	NS	NS	NS	NS	ZE	ZE	ZE
PM	NM	NM	NM	NM	NM	NM	ZE	ZE	ZE
PB	NB	NB	NB	NB	NB	NB	ZE	ZE	ZE

Table1. Fuzzy rules

Nine fuzzy levels are used for all inputs and outputs variables: NB (Negative Big), NM (Negative Medium), NS (Negative Small), NZ (Negative Zero), ZE (Zero), PZ (Positive Zero), PS (Positive Small), PM (Positive Medium), PB (Positive Big). For example, if the operating point is far to the right of the point of maximum power i.e. E is PB and change in error i.e. CE is ZE then it is required to decrease the duty ration i.e. NB to track the maximum power point. Adaptive Fuzzy Logic Control membership functions for error (E), change in error (CE).

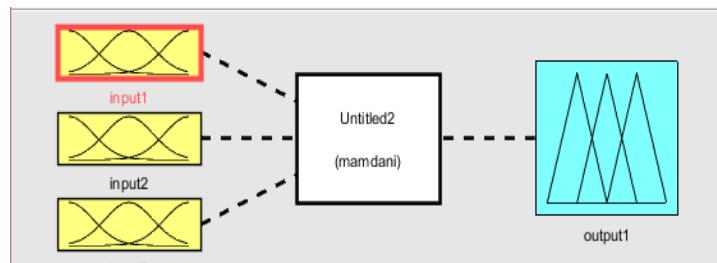

Fig 6 Unregulated input in fuzzy logic controller

V. PWM GENERATOR

Pulse-width modulation (PWM), or pulse-duration modulation (PDM), is a modulation technique used to encode a message into a pulsing signal. Although this modulation technique can be used to encode information for transmission, its main use is to allow the control of the power supplied to electrical devices, especially to inertial loads such as motors. In addition, PWM is one of the two principal algorithms used in photovoltaic solar battery chargers, the other being maximum power point tracking.



The average value of voltage (and current) fed to the load is controlled by turning the switch between supply and load on and off at a fast rate. The longer the switch is on compared to the off periods, the higher the total power supplied to the load. The PWM switching frequency has to be much higher than what would affect the load (the device that uses the power), which is to say that the resultant waveform perceived by the load must be as smooth as possible. The rate (or frequency) at which the power supply must switch can vary greatly depending on load and application. The term duty cycle describes the proportion of 'on' time to the regular interval or 'period' of time; a low duty cycle corresponds to low power, because the power is off for most of the time. Duty cycle is expressed in percent, 100% being fully on. The main advantage of PWM is that power loss in the switching devices is very low. When a switch is off there is practically no current, and when it is on and power is being transferred to the load, there is almost no voltage drop across the switch. Power loss, being the product of voltage and current, is thus in both cases close to zero. PWM also works well with digital controls, which, because of their on/off nature, can easily set the needed duty cycle.

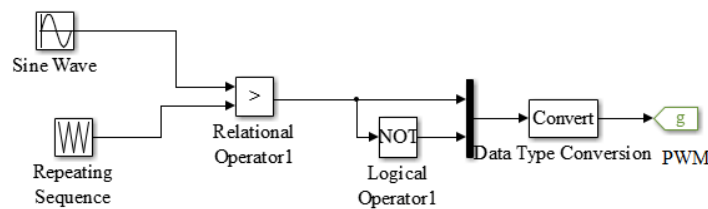

Fig6. Simulink model of PWM generator

VI. DC TO DC CONVERTER

Switched-mode DC-to-DC converters convert unregulated DC to fixed DC voltage level, which may be higher or lower, by storing the input energy temporarily and then releasing that energy to the output at a different voltage. The storage may be in either magnetic field storage components (inductors, transformers) or electric field storage components (capacitors). This conversion method can increase or decrease voltage. Switching conversion is more power efficient (often 75% to 98%) than linear voltage regulation, which dissipates unwanted power as heat. Fast semiconductor device rise and fall times are required for efficiency; however, these fast transitions combine with layout parasitic effects to make circuit design challenging. Most DC-to-DC converters are designed to move power in only one direction, from dedicated input to output.

However, all switching regulator topologies can be made bidirectional and able to move power in either direction by replacing all diodes with independently controlled active rectification. Another important improvement in DC-DC converters is replacing the flywheel diode by synchronous rectification using a power FET.

VI. INVERTER

Inverter, is an electronic device or circuitry that changes direct current (DC) to alternating current (AC). The input voltage, output voltage and frequency, and overall power handling depend on the design of the specific device or circuitry. The inverter does not produce any power; the power is provided by the DC source. A power inverter can be entirely electronic or may be a combination of mechanical effects (such as a rotary apparatus) and electronic circuitry. Static inverters do not use moving parts in the conversion process. 12 VDC, for smaller consumer and commercial inverters that typically run from a automotive electrical outlet. An inverter can produce a square wave, modified sine wave, pulsed sine wave, pulse width modulated wave (PWM) or sine wave depending on circuit design.

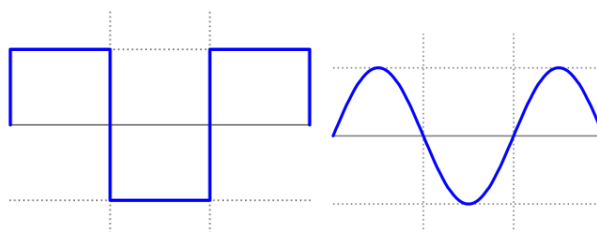

Fig7. Square wave & sine wave of inverter



VII. CONCLUSION

Detailed model of grid-connected photovoltaic generation system components, in MATLAB /Simulink software model was shown. Fuzzy controlled MPPT system is used for PV output. To generate efficient power, so it can easily and quickly track the maximum power of solar PV array. This grid connected PV systems are efficient to produce electricity. P-Q based control scheme provides fast closed loop feedback control. P-Q control scheme provide exact synchronisation of photovoltaic system with the utility grid. Also the P-Q control scheme provides independent active and reactive power control.

REFERENCES

- [1] W. Xiao, W. Dunford, and A. Capel, "A novel modelling method for photovoltaic cells," in Power Electronics Specialists Conference, 2004. PESC 04. 2008 IEEE 35th Annual, vol. 3, 2004, pp. 19501956 Vol.3.
- [2] Hiren Patel and Vivek Agarwal, "MATLAB-Based Modelling to Study the Effects of Partial Shading on PV Array Characteristics", IEEE TRANSACTIONS ON ENERGY CONVERSION, VOL 23, NO 1, MARCH 2008.
- [3] J.A.Jiang, "Maximum Power Tracking for Photovoltaic Power Systems", Tamkang Journal of Science and Engineering Vol. 8, No. 2, page(s): 147-153, 2008.
- [4] F. Blaabjerg, R. Teodorescu, Z. Chen, M. Liserre, "Power Converters and Control of Renewable Energy Systems" Aalborg Univ, Denmark PERES 2008.
- [5] K. Uchida, T. Senjyu, N. Urasaki and A. Yona, "Installation Effect by Solar Heater System using Solar Radiation Forecasting," IEEE Transactions on Transmission & Distribution Asia, 2009
- [6] K. Stefferud, J. Kleissl and J. Schoene, "Solar Forecasting and Variability Analyses using Sky Camera Cloud Detection & Motion Vectors," IEEE Power and Energy Society Meeting, San Deigo, CA, pp. 1-6, 2012.
- [7] V. P. Singh, K. Vaibhav and D.K. Chaturvedi, "Solar Power Forecasting Modeling Using Soft Computing Approach," IEEE International Conference on Engineering, Ahemadabad, India, pp. 1-5, 6-8 December, 2012.
- [8] A M. Noman, K. E. Addoweesh and H. M. Mashaly, "An intelligent FLC method for tracking the maximum power of photovoltaic systems," Electrical and Computer Engineering (CCECE), 2014 IEEE 27th Canadian Conference on, Toronto, ON, 2014, pp.1-8.
- [9] Mohamayee Mohapatra and B. Chitti Babu, "Fixed and sinusoidalband hysteresis current controller for PWM voltage source inverter with LC filter," Students' Technology Symposium (TechSym), 2010 IEEE, Kharagpur, 2010, pp. 88-93.
- [10] AK. Mukherjee and Nivedita Thakur, "A Grid Interactive PV System," in Photovoltaic Systems Analysis and Design, Eastern Economy Edition, 2011, pp. 279-310.