

Wireless Sensor Network in SCADA System for Wind Power Plant

Pavithra M¹, Priyanka N P¹, Vijayalaxmi A G¹, Manish Kumar¹, Ms. Ashutha K²

Student, Electronics and Communication, Sahyadri College of Engineering and Management, Mangaluru, India¹

Asst Professor, Electronics and Communication, Sahyadri College of Engineering and Management, Mangaluru, India²

Abstract: This paper gives communication network architecture for wind turbines to communicate directly and share sensing data in order to maximize power generation. We also designed a sensor data frame structure to carry sensing data from different wind turbine. A Web-based SCADA connected to the wind power plant simulated using Matlab-Simulink. The proposed Web SCADA controls the wind power plant. The communication between SCADA server and Simulink model is performed. The experimental results show that the proposed system achieved the goal, i.e. allowing the Web SCADA system to access the simulated WPFs modelled by Simulink in real time.

Keywords: Matlab, Simulink, web host, SCADA.

I. INTRODUCTION

A novel method is used to combine a Web SCADA server and the popular simulation software (Matlab-Simulink) for wind power plant control. The SCADA system used here is to monitor and control both individual wind turbine and whole wind farm [1].

Instead of using the real power plants, the Simulink model of power plant is modelled and connected to the SCADA software via web connection [2]. The web host method is employed for communicating the SCADA and Simulink.

In the proposed system, the Web SCADA works in the normal operation, while the parameters of hybrid power system could be changed easily by Matlab-Simulink. The control operation of Web SCADA is also simulated in the Simulink model [3].

II. SCADA SYSTEM ARCHITECTURE OF WIND POWER PLANT

Considering the wind power plant special demands, the SCADA system should have many functions such as data acquisition and processing, and systems control. Furthermore, it can compute the total power of wind generators easy way to comply with the conference paper formatting requirements is to use this document as a template and simply type your text into it [4].

A. Requirements

The data from remote devices has to send to the monitoring centre using internet. The maximum speed direction of wind turbine is detected by observing the anomaly data from measurements [5].

The SCADA system used to monitor and control both individual wind turbine and whole wind farm. With SCADA, wind power plants have to rotate to the direction with the maximum wind velocity which is important to maximize the power generation [6].

III. WEB SCADA SYSTEM DESIGN METHODOLOGY

In this work, the Web SCADA is implemented using web server. The SCADA configuration is shown in Fig. 1. The direction of wind power plants which are controlled and monitored by SCADA system.

The SCADA system typically uses a controller specific protocol to communicate with the wind turbine controller and uses an industry standard protocol, such as, Modbus for the data exchange with auxiliary devices [7]. Besides the internal communication interface, the SCADA system is designed typically to support the data exchange with external systems such as enterprise SCADA system. The list of such interfaces may include web services, and XML.

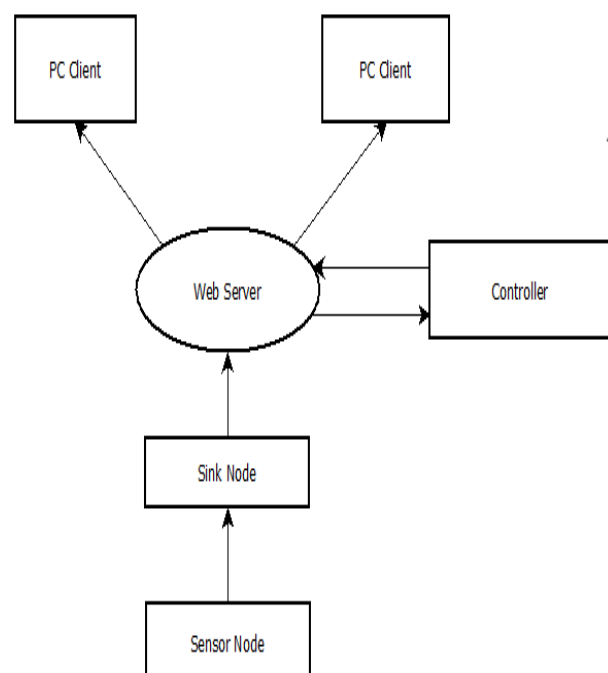

Fig. 1 Designed WSN for SCADA architecture

The communication between clients and Matlab Simulink is established via internet. The main contribution of the work is in the development of the web SCADA using Simulink to communicate with SCADA system. Once the URL connection is developed in the matlab, the power system which is modeled using Simulink could be accessed by external application like SCADA system.

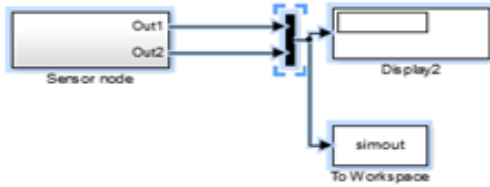

Fig. 2 Outlook of sensor node

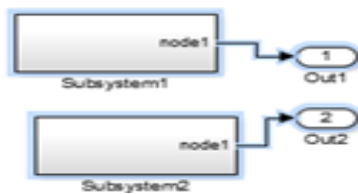

Fig. 3 Inside structure of sensor node

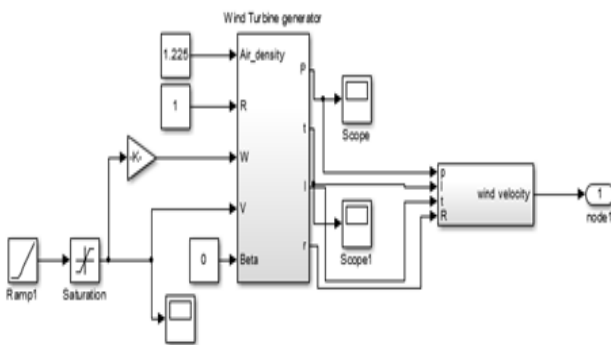

Fig. 4 Simulink model of node

Detailed Simulink model of nodes is shown in Fig. 4 where it consists of Wind generator and Wind velocity extractor. The wind energy generator model was implemented by a module having configurable parameters based on basic power and torque equation of wind turbine and using the equivalent model of a generator takes the following form and is shown in Fig. 4.

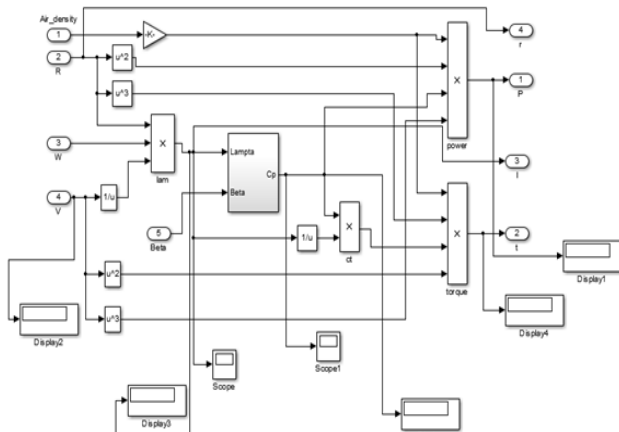

Fig. 5 Simulink model of wind generator

Velocity abstractor module is designed to abstract the wind speed from various wind plant. It uses the generated values of the power plants like torque, generated power etc., and the equation used to configure the model is given by equation (1). The equivalent model of a velocity abstractor is shown in Fig. 6. The velocity in terms of power, torque, tip speed ratio and radius of turbine can be given as:

$$V = \frac{P}{\pi T \lambda R} \dots \dots \dots (1)$$

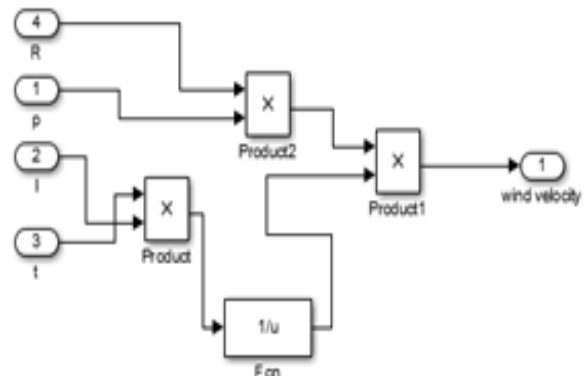

Fig. 6 wind velocity abstractor

A. Sink node

Sink node is used to abstract the data which is generated from sensor node. The master routine of sink node mainly contain task processing module, time processing module, memory processing module, data processing and correspondence module, web interface and other modules. The major part source code is compiled with Matlab to extract and send the data from sensor node to web server [9].

Here we are abstracting the data from Simulink model to work space using sim out operator. This abstracted data is sent to the URL, which has been owned by us using url read operator. Finally, sink node transmits the information to surveillance centre through Internet or satellite.

B. Web server

Here we have hosted an URL www.mvpp.org.in for a webserver, so our clients can login to this HTTP and can visualize the direction of the wind power plants. It includes our virtual representation of wind power plant i.e., we used compass to represent our wind plant and its needle to represent the direction of the plant.

C. Controller

Nodes of WSN comprise sensor node and sink node. Sensor nodes can gather and transmit data to sink node. Sensor node is composed of sensing module, processing module, communication module, and power module. Variable speed turbines are capable of controlling the generator torque, which effectively controls the rotational speed of the turbine. Variable speed generators have several different topologies including full converter systems. A reliable communication infrastructure is needed, as it plays the main part of enabling effective monitoring, operation, and protection both for WPF

generators and power systems. There is a need for smart communication networks without human intervention between the wind turbines and the control centre.

To maximize the power output and to minimize the effort the turbine controller utilizes typical open loop control algorithms. It is a one way control system where user can only visualize the tracking and not able to modify the values. The turbine’s internal supervisory controls consist of the control code in HTML and software necessary to operate the turbine autonomously from one operational state to another. The SCADA system in a WPP provides real-time visibility of the plant operations and also provides the ability to control the WPP assets centrally and remotely. It extracts the data from web server which is send by the sink node it compares the values and calculates the maximum velocity value. Depending upon the maximum velocity value it detects the direction of high wind velocity, and then it rotates our wind turbines to the maximum velocity direction. Here we used two wind power plants for representation.

D. PC CLIENT

Here our client can visualize the tracking of wind power plant. Our login address will be provided for our clients [8].

IV. EXPERIMENTAL RESULTS

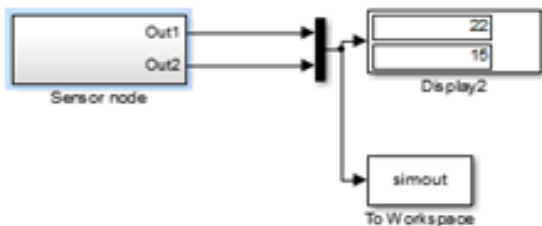

Fig. 7 Simulated output of sensor node

The Simulink model consists of sensor nodes which are nothing but two wind turbine generators and wind velocity extractors which abstract wind speed from various wind plant. To provide the real-time simulation, the Simulink Real Time Execution is employed. The result of simulation is shown in following figures.

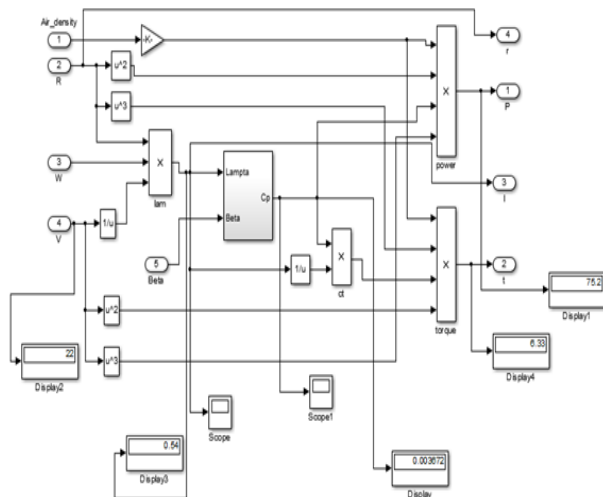

Fig. 8 Simulated output of node1

The Web SCADA animation display is shown in Fig. 10 and Fig. 11, which are used to represent the simulated Simulink model to display in the web browser. The web SCADA animation display consists of speedometer and compass. The speedometer shows the velocity of wind obtained by different wind power plant. The compass points to the direction in which maximum velocity is obtained. The maximum velocity obtained at node1 shown in Fig. 10. The maximum velocity obtained at node2 is shown in Fig. 11.

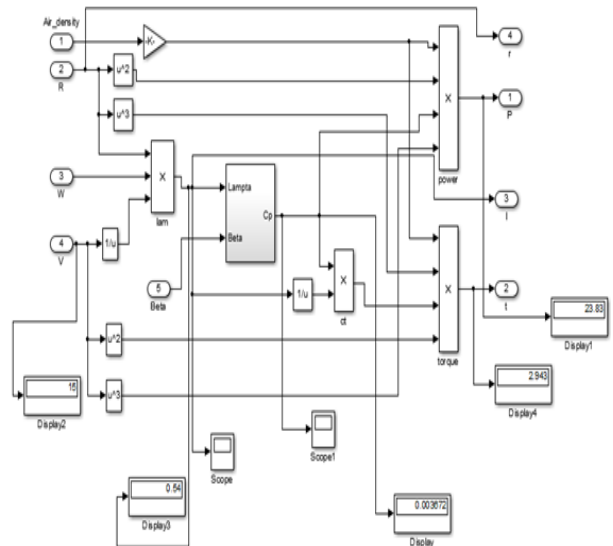

Fig. 9 Simulated output of node 2



Fig. 10 Web output with maximum velocity at node1



Fig. 11 Web output with maximum velocity at node2

V. CONCLUSION

The method to combine the real Web SCADA software and simulation model using Simulink is described. The proposed Web SCADA system is designed to control and monitor the speed and direction of the wind power plant. Both the Web SCADA software and Simulink could be communicated in real time. The control action and monitoring operation of the SCADA system could work properly. In future, the developed system will be expanded to include the sophisticated supervisory control system of wind power plant system. Further, the more SCADA features will be implemented.

ACKNOWLEDGMENT

We acknowledge Sahyadri College of Engineering and Management for providing space for implementation of our project and also HOD of ECE Dept & department of Electronics and communication for guidance and support.

REFERENCES

- [1] Xingzhen Bai, Xiangzhong Meng, Zhaowen Du, "Design of Wireless Sensor Network in SCADA System for Wind Power Plant", Proceedings of the IEEE International Conference on Automation and Logistics Qingdao, China, pp. 3023-3027, Sept. 2008.
- [2] Aryuanto Soetedjo, Abraham Lomi, Yusuf Ismail Nakhoda, "Combining Web SCADA Software and Matlab-Simulink for Studying Wind-PV-Battery Power Systems", International Journal of Computer Science Issues, Vol. 10, No.2, pp. 51-57, Mar. 2013.
- [3] Mohamed A. Ahmed and Young-Chon Kim, "Communication Network Architectures for Smart-Wind Power Farms", Energies, vol. 7, pp. 3900-3921, 2014.
- [4] Ashutha K., Ankitha K., "Smart Shopping cart using embedded system and wireless module", Recent Patents on Computer Science (CSENG), UAE, Vol. 8, pp. 1-6, January 2016.
- [5] Ashutha K., Shetty Arpitha., et.al "Novel wireless data communication for fisherman", International journal of computer science and mobile computing (IJCSMC), Vol.5 Issue.4, pp. 511-517, April 2016.
- [6] Ashutha K., Ankitha K., "Error Minimization in BCH Codes", International Journal Of Innovative Research In Electrical, Electronics, Instrumentation and Control Engineering (IJREEICE), Vol. 4, Issue 5, pp. 402-405, May 2016.
- [7] B. Badrzadeh, M. Bradt, N. Castillo, R. Janakiraman, R. Kennedy, S. Klein, T. Smith, L. Vargas, "Wind Power Plant SCADA and Controls", IEEE IPES Wind Plant Collector System Design Working Group, 2012.
- [8] Federico Hahn, Mauricio Pablo, Jose Reyes, "Solar Driven Wind Speed Monitoring System Using Wireless or Wired Sensors", Energy and Power Engineering, vol. 6, pp. 213-221, 2014.
- [9] Yanjing Meng and Wenzhan Gong, "Design of SCADA System Based on Wireless Communication for Offshore Wind Farm", LNEE, vol. 127, pp. 347-352, 2012.