

High Brightness Led Driver with film capacitor

Jeffrin Joshva. A¹, Easwaran .M², Shahimol Basheer³

UG Scholar, Dept. of EEE College of Engineering, Munnar^{1,2}

Assistant Professor Dept. of EEE, College of Engineering, Munnar³

Abstract: High brightness light-emitting diodes are considered as a remarkable lighting device due to their high reliability and chromatic variety. In this paper a three stage solution and design of the led driver proposed, Power factor correction achieved by boost converter, galvanic isolation by electronic transformer and current regulation by buck converter at the last stage. A design of led driver with high reliability proposed in the paper.

Keywords: AC-DC Power converter, Electronic transformer, Light-emitting diodes (LED), Three-Stage topology, Two-input buck converter.

I. INTRODUCTION

High-Brightness Light Emitting Diodes (HB-LEDs) are considered as a remarkable lighting device due to their high reliability, chromatic variety and increasing efficiency. As a consequence, a high number of solutions for supplying LED strings are coming out. One-stage solutions are cost-effective, but their efficiency is low as they have to fulfill several purposes with only one converter: Power Factor Correction (PFC), galvanic isolation (in some cases) and current regulation. Two-stage and three-stage solutions have higher efficiency as each stage is optimized for just one or two tasks and they are the preferred option when supplying several strings at the same time. Nevertheless, due to their higher cost in comparison to one-stage solutions, they are used when high-efficiency, high-performance and the possibility of supplying several strings are the main concerns. Besides, they are also used when high reliability is needed and electrolytic capacitors cannot be used. In this paper, a three-stage solution and its complete design guideline for LED-based applications is proposed. PFC is achieved by a Boost converter while the galvanic isolation is provided by an Electronic Transformer (second stage). The third stages (one for each LED string) are designed following the Two Input Buck schematic, but taking advantage of the load characteristics (i.e., the high value of the LED string knee voltage, approximately equal to half the string nominal voltage). Besides, a variation of the analog driving technique is also proposed. Experimental results obtained with a 9-W prototype show an efficiency as high as 93 Percentage for the whole topology and 95 Percentage for the cascade connection of the second and third stages.

II. PROPOSED SYSTEM

In this prototype model we reduce the voltage from 230Vac to 12Vac using step down transformer then the ac signal is Jeffrin Joshva. A, Easwaran .M, UG scholars, College Of Engineering, Munnar And Shahimol Basheer, Assistant professor in the Department of Electrical and Electronics Engineering Idukki, Kerala, 685612, India.

converted to dc using rectifier circuits with suitable filtering circuits using film capacitors and the rectified voltage is boosted up with the booster circuit using an inductor and MOSFET. This mosfet is switched according to the pulses detected by the zero crossing detectors. The boosted voltage is directly given to the electronic transformer. Totally two electronic transformers are used here one for one set of LED's and another one is for the other set of LED's. The current rating of the transformer is 1 amps and it is generally called as centre tapped transformer by switching the transformer through the mosfet we generate the high voltage. By using the high current rating transformer we use more number of LED's. Totally we used to centre tap transformer we have to use four MOSFET for switching that transformers and the input step down transformer is 1 Amps only. While switching this transformer we need more power otherwise we cannot boost the voltage using electronic transformer to get more power we use battery power additionally and switching this mosfet continuously with 50HZ.

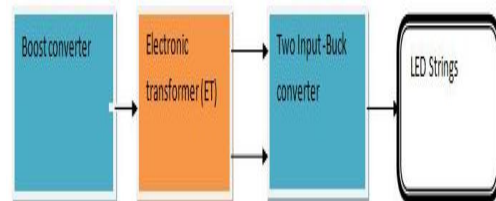

Fig. 1: Block diagram of the proposed system

Here we used two set of Two Input-buck converter with one MOSFET and inductor using this Two-input-buck converter the usage of this converter is to improve the brightness of the LED's. Totally the micro controller has to switch all the mosfet with specified frequency of 50Hz. Because the electronic trans-former is designed for 50Hz and the input ac supply frequency is also the same frequency. Using this method we can improve the efficiency of the LED's brightness and in this rectifier

circuit we did not use any type of electrolytic capacitors we used only film capacitors The electronic transformer is used for boost the voltage and for isolation purpose this is one of the main advantage of the project the isolation will protect the controller part.

The TI-buck is introduced in this project it takes benefit from the high value of the led string voltage. It reaches full dimming in LED's although its output voltage range is limited. Hence the proposed topology has a very high reliability. The use of amplitude mode driving technique as it has lower current stress on LEDs and semi conductors than the pulse width modulation (PWM) driving technique. Two other important aspects should be highlighted, the whole converter operates at constant frequency, and it provides the isolation. Finally, it should be mentioned that this approach to the driving technique is compatible with both amplitude-mode and Pulse with modulation mode dimming. In addition, adding communication options, such as digital addressable lighting interface (DALI) to this driver is straight forward.

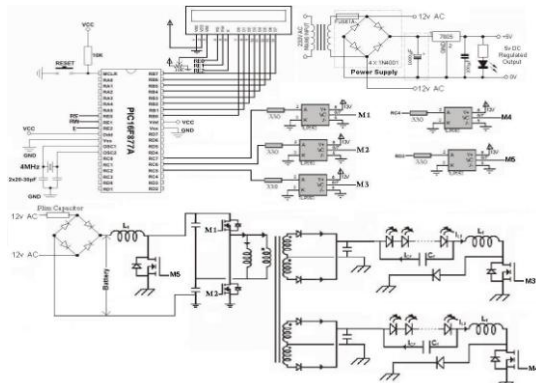

Fig. 2: Design of the proposed system

A. First Stage (Boost Converter)

First stage is a boost converter and it has proven to be a perfect option for doing power factor correction. Designed without electrolytic capacitor output voltage ripple cannot be neglected and this ripple voltage will affect the second and third stage. This topology can reach efficiency up to 97 percentages. It operates at boundary condition. The boost converter has a mosfet switch which is switched at a frequency of 50 Hz from the micro controller.

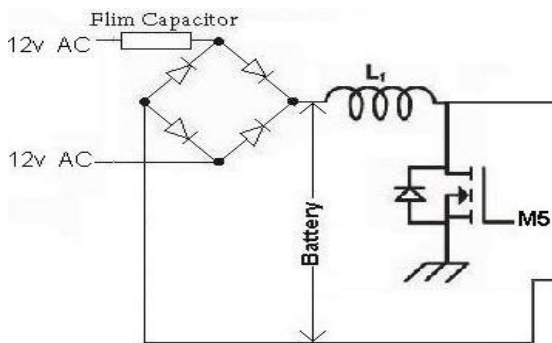

Fig. 3: Basic schematic of the Boost converter

B. Second Stage (Electronic Transformer (ET))

Optimized for providing galvanic isolation at very high efficiency. Applied to a two-output half-bridge topology and MOSFET switched at constant frequency of 50Hz.galvanic isolation is a mandatory requirement. Hence it is vital to find a topology capable of providing it with very high efficiency. This opens the possibility of using an electronic transformer, which is an unregulated topology with very high efficiency. The main idea is operating the MOSFET at constant frequency of 50 Hz.

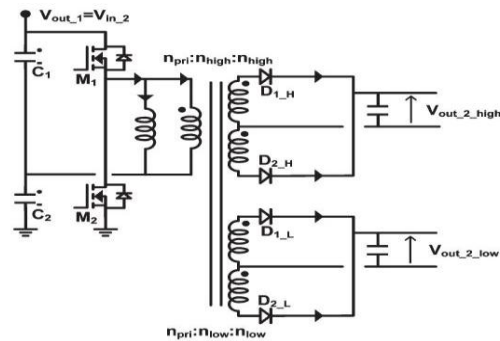

Fig. 4: Schematic of the electronic transformer

C. Third Stage (Two Input-Buck converter)

Eliminating the voltage ripple coming from the electronic transformer (ET) outputs (due to the first stage) .Adjusting each LED string current to the desired level. The third stage have to, not only regulate the current provided to the led string, but also cancel the low-frequency ripple that affects the output voltages the first and the second stages.

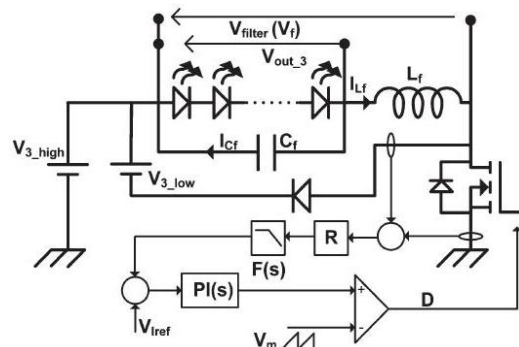

Fig. 5: Schematic of the Two Input-Buck converter

III. PROPOSED HARDWARE

The High-Brightness LED driver with film capacitor hardware implemented with 8 LED's .The proposed topology hardware is implemented with 3 stages like boost converter, electronic transformer, Ti-buck converter. Here we used two set of Two Input-buck converter with one MOSFET and inductor using this Two Input-buck converter the usage of this converter is to improve the brightness of the LED's. Totally the micro controller has to switch all the MOSFET with specified frequency of 50Hz. Because the electronic

transformer is designed for 50Hz and the input ac supply frequency is also the same frequency. Using this method we can improve the efficiency of the LED's brightness and in this rectifier circuit we did not use any type of electrolytic capacitors we used only film capacitors. Finally, it should be mentioned that this approach to the driving technique is compatible with both amplitude-mode and Pulse Width Modulation (PWM) mode dimming. In addition, adding communication options, such as digital addressable lighting interface (DALI) to this driver is straight forward.



Fig. 6: High-Brightness LED Driver with Film Capacitor

IV. RESULT

The outputs of the High brightness led driver obtained .The prototype consist of 8 LED's, this topology is proven to have high reliability and efficiency High brightness is delivered by the LED's using the proposed topology. Implemented as light-ing device. The proposed topology can be also implemented as street lighting device. It is easy to operate. In this paper, a con-verter for LED-based street lighting application is presented. It is based in a three-stage topology. Each stage is designed for one specific task, in such a way that the overall efficiency. In addition, it is a solution with Film capacitor; hence, it has high reliability. A le d's nominal voltage is 3.9V, nominal current is 0.350A .8 LED's can draw voltage ($3.9V \times 8 = 31.42V$).The output power of the le d's is 10.9W. So the efficiency of the driver is calculated using the output power of led's and the input power .The input power of the proposed topology is 12W. so while calculating the efficiency of the driver the efficiency is found to be 91 percentage on the whole. So can be implemented as an lighting device.

V. CONCLUSION

A High Brightness led driver application is presented. It is based on a three-stage topology .Each stage is designed for



Fig. 7: High-Brightness LED Driver with Film Capacitor

one specific task. experimental results have been obtained with a prototype designed for 8 LED .Achieving an efficiency at full load as high as 93 Percentage for the second and third stages in cascade. The first stage of the proposed solution is the very-well known boost converter. Its main task is achieving PFC with high efficiency. The second stage is an ET. It provides two output voltages with a fixed gain (unregulated) between input and outputs. Its task is providing galvanic isolation. The third stage is a Two Input-Buck. While the first two stages are common, each LED string is connected to a Two Input-Buck. In this way, the current of each string can be regulated independently. In addition, the first stage has a considerable output voltage ripple due to the absence of electrolytic capacitors. As the second stage is unregulated, this ripple has to be cancelled by the third stage.

REFERENCES

- [1] High efficiency LED driver without electrolytic capacitor for street lighth ing,manuelArias, Member, IEEE, Diego G. Lamar, Member, IEEE, Javier sebastian, Senior Member, IEEE, Didier Balocco, and Almadidi Aguisa Diallo.
- [2] T. Siew-Chong, General N level driving approach for improving electrical-to-optical energy-conversion efficiency of fast-response sat-urable lighting devices,IEEE Trans. Ind. Electron., vol. 57, no. 4,pp. 13421353, Apr. 2010.
- [3] G. Linlin, R. Xinbo, X. Ming, and Y. Kai, Means of eliminating electrolytic capacitor in AC/DC power supplies for LED lightings,IEEE Trans. Power Electron., vol. 24, no. 5, pp. 13991408, May 2009.
- [4] H. Ma, W. Yu, C. Zheng, J.-S. Lai, Q. Feng, and B.-Y. Chen, A universal-input high-power-factor PFC pre-regulator without electrolytic capacitor for PWM dimming LED lighting application, in Proc. IEEE ECCE, 2011, pp. 22882295.
- [5] H. Ma, W. Yu, Q. Feng, J.-S. Lai, and C. Zheng, A novel SEPIC-derived PFC pre-regulator without electrolytic capacitor for PWM dimming LED lighting application based on valley fill circuit, in Proc. IEEE ECCE, 2011, pp. 23102317.
- [6] K. I. Hwu, Y. T. Yau, and L. Li-Ling, Powering LED using high-efficiency SR flyback converter,IEEE Trans. Ind. Appl., vol. 47, no. 1,pp. 376386, Jan./Feb. 2011.
- [7] Q. Hu and R. Zane, Off-line LED driver with bidirectional second stage for reducing energy storage, inProc. IEEE ECCE, 2011, pp. 23022309.
- [8] Q. Hu and R. Zane, Minimizing required energy storage in off-line LED drivers based on series-input converter modules,IEEE Trans. Power Electron., vol. 26, no. 10, pp. 28872895, Oct. 2010.
- [9] C. Spini, 48 V-130 W High Efficiency Converter with PFC for LED Sreet Lghting Applications European Version, STMicroelectronics, Geneva, Switzerland, AN3105 Appl. Note, 2010.
- [10] D. Bailey, An idea to simplify LED lighting purchase decisions, Bodos Power System, Laboe, Germany, p. 18, 2011.