



# Development of User Friendly Data Acquisition and Actuation System on Embedded Platform

Moolya Ashwar Shankar<sup>1</sup>, Sukesh Rao M.<sup>2</sup>

Department of Electronics & Communication Engineering, NMAMIT, Nitte, Karnataka, India.<sup>1,2</sup>

**Abstract:** The proposed system accepts both digital and analog signals of different precision. The system works in two ways, data acquisition mode and actuation mode. During data acquisition operation the analog values or digital bits are read by the processor, where the processing is carried out based on the constraints provided by the user through GUI. The processed data is transferred by embedded controller to the Host PC with the help of a Universal Serial Bus hub/Host controller, connected through a serial Bus (USB2.0). Data acquisition starts with the input provided by the user command. The Embedded Host controller unit performs the data acquisition and transmits to the Host PC via USB. In data actuation operation the input can be analog value or digital value. When user provides digital value in Host PC, digital input values are given to processor via USB. The processor unit performs processing by converting digital input to analog output values, result will be obtained from output port of processor. When user gives a value in Host PC, the value gets converted to digital format by PC which can be interpreted by the system. Discrete values are given as input to processor unit via USB. The Analog to Digital converter will be performed in processor by converting discrete values to analog output. Analog output values are obtained from output ports of processor.

**Keywords:** GUI, Host PC, mbed NXP LPC 1768 embedded controller, ADC, DAC, USB.

## I. INTRODUCTION

Data acquisition is the process of sampling signals that measure real world physical conditions and converting the resulting samples into digital numeric values that can be manipulated by a computer. Data acquisition systems typically convert analog waveforms into digital values for processing. Data acquisition interfaces helps in measuring information provided by both digital and analog signals. Digital signals can come from variety of sources such as switch closures, relay contacts or TTL compatible interfaces. Through proper interfaces they can be read directly and processed by computers. Similarly an actuator is a type of driver circuit that is responsible for controlling a system.

An actuator is a type of driver circuit that is responsible for converting given discrete values to analog or some sort of data manipulation for the given data links. Using the actuator circuit the user input is converted into a control signal which can be interpreted by the system. Here the system can be simple mechanical or electronic systems like a printer, robot control system etc.

Our user friendly system accepts both digital and analog signals and it works in two ways, data acquisition mode and actuation mode. During the data acquisition mode, the analog values are passed to the ADC by the user through input port which is connected to mbed NXP LPC1768 Host controller. Then the embedded Host controller unit does the data acquisition and transmits data to the Host PC via USB. During the data actuation mode the digital values entered by the user in the host PC

are passed to the mbed NXP LPC1768 via USB. Then the embedded Host controller unit does the data actuation and output is obtained from the analog output port of mbed NXP LPC1768.

## II. RELATED WORK

In data acquisition (DAQ) systems [1], analog signals can be acquired and processed. Today Intel based multi-core processors have acquired the capability to perform signal processing functions on the digitized data of multi-channel underwater surveillance systems. A major concern is acquisition of data from an underwater sensor array having multiple analog input channels. This presents a 96 channel data acquisition system comprising of Intel processor based industrial PC mainframe running Windows. The suggested system consists of three PCI data acquisition boards for acquiring 96 channels of acoustic data. Mostly underwater arrays have more number of analog inputs than the maximum number of analog inputs present on a commercially available data acquisition board. This requires a PC based system utilizing multiple data acquisition boards. A typical PC based DAQ system has five major modules namely PC, Analog input module, Front End conditioning, DAQ board(s) and software. The PC based DAQ system in this comprises of 32-channel PCI-24DSI32 analog input boards by ACQUITEK. This DAQ board is suitable for audio processing applications. It supports multi-board synchronization and simultaneous sampling. These two factors are important for obtaining accurate beam forming outputs for underwater sensor arrays.



A newly designed idea is proposed with ARM9 processor [2] as the core components to design a common data acquisition system. A user-defined data acquisition system is formed according to different signals. Hardware structure is made up of Web Server, ARM9 system board and the multi-block STM8L data acquisition board. With Linux as the operating system and based on the Qt platform ARM9 as system board develops the application program and completes the corresponding tests. It mainly includes in accordance with the actual application requirements, It proposes that the system should focus on the characteristics of high-precision, high speed, low-power and strong anti-jamming to design, and gives the overall system design and structural design of intelligent nodes. The concrete hardware circuit design of common data acquisition system has been accomplished, which mainly includes designing STM8L data acquisition board and ARM9 system board]. The concrete software design of common data acquisition system has been accomplished, which mainly includes building Linux operating system, building Qt development environment, ADC, digital filtering, designing real-time data communications, and real-time graphics display applications and so on. Because it is battery-powered in STM8L data acquisition board, the system needs to work with low power. Based on the analysis of energy consumption in STM8L data acquisition board, the system has adaptive mechanisms of sleep to reduce system power consumption, ensuring the system can orderly run for a long time. The universal data acquisition system consisting of hardware and software platforms, based on ARM9 microprocessor core. We just need to choose different data acquisition boards according to different measured signals, and then a user-defined data acquisition system can be formed conveniently and flexibly.

Data acquisition is one of the most important sections in modern industry controlling system, and more and more technologists are putting much emphasis on this kind of study.

In ARM kernel microprocessor [3], they have designed a Microprocessor minimum system which based on ARM7 kernel Microprocessor S3C44BOX. And on the basis of the Minimum System a kind of data acquisition card which based on USB interface is designed. A kind of embedded operating system Ji C/OS- II also has been transplanted in the data acquisition; also a Ji C/OS – II is used to manage the whole data acquisition system. The whole data acquisition systems design includes hardware circuits' design and data acquisition interrupt software's design. After being used and examined practically, the USB data acquisition card takes on such advantages as good performance, low consumption and low cost, especially for its use value. And it can be embedded in many kinds of data acquisition applications as a basic module. This kind of design will help the modern industry controlling and producing greatly.

By comparing the above papers, we have concluded that the response of the proposed system is faster as it easily accessible and it also uses a USB protocol which is much faster than above mentioned system. In proposed system, the data acquisition operation is successfully performed on the mbed NXP LPC1768 embedded model. This mbed NXP LPC1768 is an ARM Cortex-M3 based microcontrollers for embedded applications featuring a high level of integration and low power consumption.

### III. SYSTEM DESCRIPTION

#### 3.1 Functional Block Diagram:

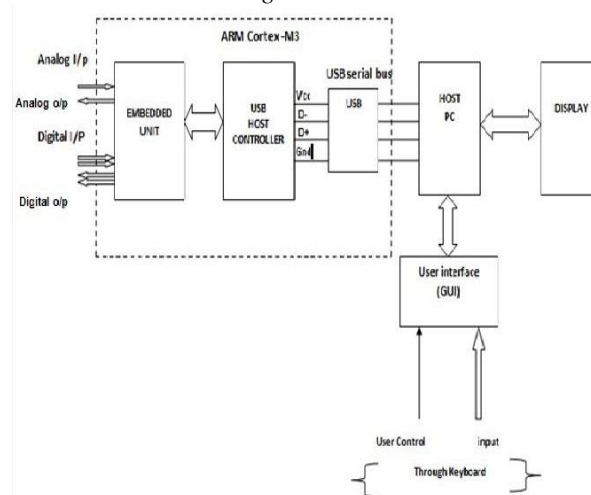

Figure 1: Block diagram of data acquisition and actuation system on embedded platform

Figure 1 describes the functional Block diagram representation for the development of user friendly data acquisition technique. Data acquisition operation is performed on the embedded system, which includes components such as embedded unit, USB Host controller, USB serial bus, Graphical User Interface on Host PC and output display device.

*Embedded unit:* This data acquisition technique uses mbed NXP LPC1768 as the embedded unit. The ARM Cortex-M3 processor is the industry-leading 32-bit processor for highly deterministic real-time applications, delivering robust computational performance, exceptional system response to events while meeting the challenges of low dynamic and static power constraints. The Cortex-M3 is highly configurable, enabling a wide range of implementations from those requiring memory protection and powerful trace technology to cost sensitive devices requiring minimal area. A broad range of devices include microcontrollers, automotive body systems, industrial control systems and wireless networking and sensors. The LPC1768 operate at CPU frequencies of up to 100 MHz and the inputs to the embedded unit may be analog or digital in nature. Embedded unit converts the given data it may either convert the ADC or Digital to Analog Converter (DAC) based on the input provided by the



external sources. The processed data after the conversion is provided to the USB Host controller.

The USB Host Controller, which is integrated in the USB or FireWire hardware to communicate with a host controller driver in software. The driver software is typically provided with an operating system of a personal computer, but may also be implemented by application-specific devices such as mbed LPC1768. The data processed after the conversion from the mbed LPC1768 is provided to the USB Host controller, where this device controls the number of Hosts. It passes single data at a time to the USB.

The USB is a 4-wire bus that supports communication between a Host and one or more (up to 127) peripherals. The Host controller allocates the USB bandwidth to attached devices through a token-based protocol. The bus supports hot plugging and dynamic configuration of the devices. All transactions are initiated by the Host controller. The USB interface includes a Host device which is an on-chip device and Host functions. The switching protocol is supported through the use of an external controller.

Pin	Name	Cable color	Description
1	VCC	Red	+5VDC
2	D-	White	Data -
3	D+	Green	Data +
4	GND	Black	Ground

Table 1: Pin configuration for USB

Table 1 shows the pin configuration for the USB 2.0 serial bus. It uses 4 shielded wires, two for power (+5v & GND) and two for differential data signals (labeled as D+ and D- in pin out). NRZI (Non Return to Zero Invert) encoding scheme used to send data with a field to synchronize the Host and receiver clocks. In USB data cable Data+ and Data- signals are transmitted on a twisted pair. Half-duplex differential signaling helps to combat the effects of electromagnetic noise on longer lines. Contrary to popular belief, D+ and D- operate together; they are not separate simplex connections. USB provides for a maximum cable length of 5 meters for devices running at Hi Speed.

**Graphical User Interface (GUI):** A graphical user interface (GUI) is a type of interface that allows users to interact with mbed controller through graphical icons and visual indicators that enable a user to perform interactive tasks. The user of the GUI does not have to create a script or type commands at the command line to accomplish the tasks. Unlike coding programs to accomplish tasks, the user of a GUI need not understand the details of how the tasks are performed. GUI components can include menus, toolbars, push buttons, radio buttons, list boxes, and sliders. The actions in a GUI are usually performed

through direct manipulation of the graphical elements. In addition to computers, GUIs can be found in hand-held devices such as MP3 players, portable media players, gaming devices and smaller household, office and industry equipment. The creation of GUI is accomplished with the help of a coding language called VB.NET.

**Host PC and the display device:** Host PC is system which operates through an operating system and supports many languages like VB.NET, C, C++ etc; Host PC is connected to the processor via USB. In data acquisition mode, the Host PC is used to verify output result and in data actuation mode Host PC is used to provide input to processor via USB..

A display device is an output device that visually conveys text, graphics and video information. Information shown on a display device is called soft copy because the information exists electronically and is displayed for a temporary period of time. When the input information is supplied as an electrical signal, the display is called an electronic display. The display device is used for the visualization of the results. The required output results are displayed on this display device.

3.1.1. Data acquisition:

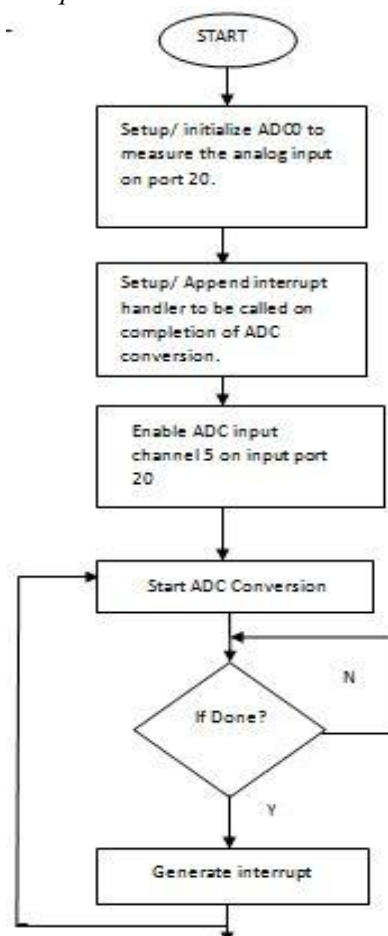

Figure 2: Flow chart for ADC



Figure 2 shows flow chart for ADC module tested on mbed LPC1768. The testing is carried by providing analog input voltage ranging from 0 to 3.3v provided to input port 20 of mbed LPC1768. A variable resistor is used to get the distinct values on the analog input port. ADC conversion is verified through 12 bit digital output ports (port 9 to port 14 and port 21 to port 26) and a series of LED's are connected for simplification of verification. User can provide continuous analog input voltage to mbed LPC1768, when user provides maximum analog input voltage all the LED's will be ON. When user provides zero analog input voltage all LED's will be OFF.

3.1.2. Data actuation:

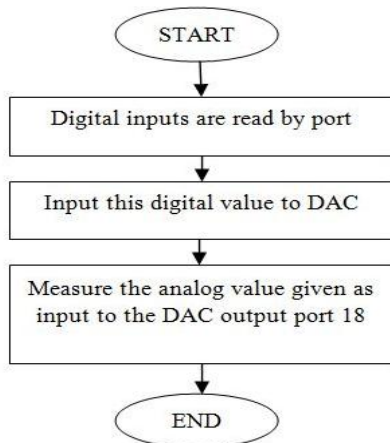

Figure 3: Flow chart for DAC

Figure 3 shows the flow chart to test the DAC operation on the mbed LPC1768 microcontroller. The testing is carried by looping back the ADC converted value as 12 bit digital input ranging from 0 to 4095 to the DAC. A variable resistor is used to change the analog input voltage and there by getting different digital value for the ADC module. Then digital values are used by DAC for the D to A conversion. DAC conversion is verified through measuring analog output voltage obtained from port 18 of mbed NXP LPC1768 and comparing it with the analog input given to port 20.

3.1.3. Sample example on graphical user interface:

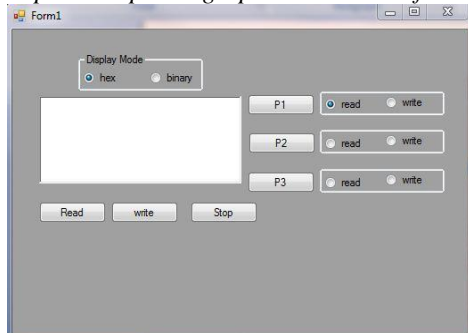

Figure 4: Snapshot of graphical user interface using VB.NET

Figure 4 shows the snapshot of the programmable graphical user interface using the VB.NET language. The VB.NET application is the programming language and is used to display the results on the display device through the graphical user interface. The display mode on the graphical user interface can be either hexadecimal or binary mode. The graphical user interface created in the Figure 4 mainly consists of six radio buttons and three check boxes. Three of the radio buttons namely P1, P2 and P3 shown in the Figure 4 is linked to three operations, where the response of the system is needed. Other three radio buttons are linked to operations on Read, Write and Stop respectively as shown in the Figure 4 Each of the three check boxes includes two radio buttons namely read and write.

When P1 radio button is activated, the data stored in the port P1 will be read by performing read operation and will be displayed in hexadecimal or binary mode by performing write operation. And when P2 radio button is activated, the data stored in the port P2 will be read by performing read operation and will be displayed in hexadecimal or binary mode by performing write operation. Similarly when P3 radio button is activated, the data stored in the port P3 will be read by performing read operation and will be displayed in hexadecimal or binary mode by performing write operation. The stop radio button resets the created graphical user interface. The results for a particular port are displayed in two different forms, one in the hexadecimal format and other in the binary format. The required form of result can be obtained by just clicking on the radio buttons present in the dialogue box present in the graphical user interface under display mode.

IV. RESULTS AND ANALYSIS

The resulting output shows the data acquisition and data actuation. The Figure 5 shows the conversion of A to D of a data acquisition and also shows the conversion of D to A of data actuation.

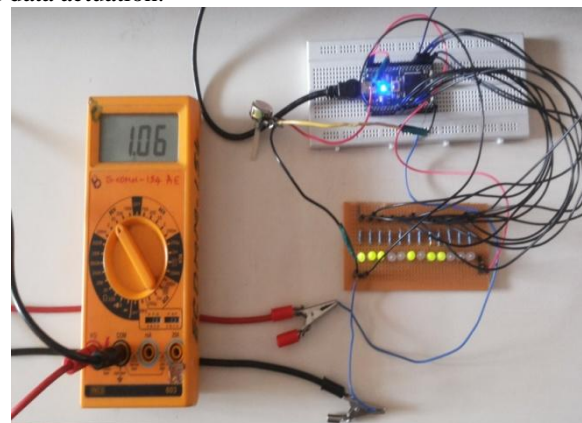

Figure 5: Moderate stage

According to the input voltage variation by variable resistor, we can observe some LED's are ON and some are OFF. The LED value indicates the corresponding digital



output for a particular analog signal thus verifying the working of ADC (Data acquisition).

The working of DAC (Data actuation) is then verified by feeding this digital output as input. The analog output of the DAC is compared with the initial analog signal given to ADC to verify the result.

## V. CONCLUSION

The proposed system works in two modes, data acquisition mode and data actuation mode. With help of mbed online compiler .bin file is deployed into mbed LPC1768 through USB in both modes. In data acquisition mode, the testing of ADC module is achieved by mbed LPC1768. Result is verified on the input output ports of mbed device. Similarly in data actuation mode loop back method is used where ADC module output is used as input to DAC of mbed LPC1768 and result is verified through analog output port. The integration of embedded controller with host PC is achieved by building GUI using VB.NET to represent the data transfer through USB communication.

## REFERENCES

- [1] Umar Hamid, Rahim Ali Qamar, Mohsin Shahzad, "2013," PC Based Data Acquisition and Signal Processing for Underwater Sensor Arrays"; Proceedings of 2013 10th International Bhurban Conference on Applied Sciences & Technology (IBCAST).
- [2] Wang Jiannong, Wang Wei, ICEMI "2011," The Common Data Acquisition System Based On Arm9"; The Tenth International Conference on Electronic Measurement & Instruments.
- [3] Yujun Bao, Xiaoyan Jiang, ICCASM "2010," Design of USB Data Acquisition Card which based upon ARM kernel Microprocessor"; 2010 International conference on computer Application and System modeling.
- [4] LPC1768 User Manual" Philips Semiconductors.
- [5] [www.mbed.org](http://www.mbed.org)
- [6] [http://en.wikipedia.org/wiki/Universal\\_serial\\_bus](http://en.wikipedia.org/wiki/Universal_serial_bus).