

# Automatic Ventilation of Vehicle Interior and Driver Fatigue Monitoring & Controlling System

P.V.S.Usha<sup>1</sup>, S.Raj Kumar<sup>2</sup>

M.Tech (ECE), Mallareddy Engineering College for Women, JNTU, Hyderabad, India

Assistant Professor (ECE), Mallareddy Engineering College for Women, JNTU, Hyderabad, India

**Abstract:** In order to mitigate overheated interior of a vehicle parked in the hot summer sun and thereby to make the entering into the vehicle more comfortable, microcontroller managed module for automatic ventilation of vehicle interior is made. The module is implemented using a microcontroller as a central logical unit and a series of sensors which provide sufficient data to ensure functional, but also efficient, reliable and safe ventilation. The ventilation process is performed by opening vehicle windows slightly, which enables air to circulate. The PIC microcontroller controls the car head light system during the night time travel by controlling the high beam and low beam lights. The system is embedded with MATLAB which access the camera and monitors the position of driver face. It can avoid the accidents by alert the driver using alarm or by stopping the vehicle. This paper shows the components, their purpose and capabilities, advantages and disadvantages, as well as potential implementations and upgrades. The test results give insight into utilization options of this module and its usefulness.

**Index Terms:** PIC, MATLAB.

## I. INTRODUCTION

The present system monitors [1] the health condition of vehicle in different environmental conditions. The system also provided to avoid accidents due to the negligence of driver. The system provided with different sensors such as temperature sensor, precipitation sensor, light sensor, security sensor. The predefined algorithm uses the sensors data obtained from vehicle surroundings in different environmental conditions and performs the necessary action to maintain the condition of vehicle which ensures more comfort to the driver. The system uses a camera and MATLAB which is [2] embedded with the system. It allows monitoring the position of driver face. A serial communication is established between the system and PC. If drowsiness occurs by driver, the head of the driver fall to other side of camera frame size. If microcontroller identifies no face with-in the frame size, then the vehicle get stopped or an alertness given by buzzer. The existing system is not powerful enough to provide comfort to the driver in different environmental conditions. The system is provided with proper door locking system, car engine heat [3] monitor system. This provides the monitoring of a single health condition of vehicle. The proposed system is provided with monitoring and controlling of health system of vehicle in different environmental conditions.

The system is provided with sensors such as temperature, precipitation, light and security. These sensors monitor vehicle surroundings and interior and controls as per the changes in environment. It is also provided to avoid the accidents due to the drowsiness of the driver. The proposed system is designed to make more comfortable, safe and secure travelling. Hence the vehicle has to make modifications with sensors which are monitor and control by the central core system such as microcontroller.

The PIC microcontroller such as 16F877A. It has wide range of features such as 8KB Flash ROM, 368 bytes of on chip RAM, 256 bytes of EEPROM, 1 serial port. The sensors such as [3][4] LM35 (Temperature sensor), PIR

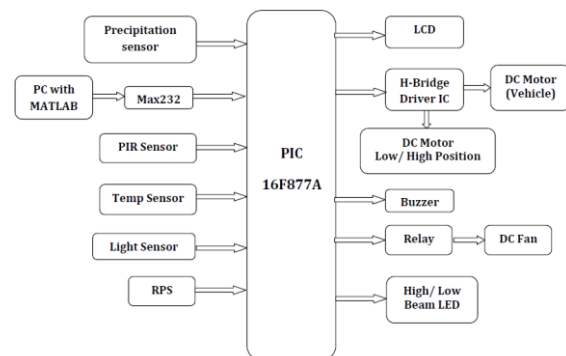

Fig.1.1 Block Diagram

(Security sensor), LDR (Light sensor), Precipitation sensors are used to make more comfortable of the interior of the vehicle. The system is also facilitated with the safety of the driver or vehicle. Due to the long drive, the driver may get drowsiness and it leads to accidents. When an alarm or body vibration is given to driver whenever he feels drowsiness. Due to drowsiness, the position of head changes. This factor is considered and captured through a webcam. The cam is interfaced to MATLAB through serial communication. The MATLAB system processes the image and authenticate. When the vehicle driver head is with the camera frame, the MATLAB found the face and authenticate to start the vehicle. If the head falls out of the camera frame due to the drowsiness, the MATLAB process and does not authenticate the vehicle and the vehicle get stopped or buzzer gives alarm. The camera is interfaced with serial port of the microcontroller. The 25<sup>th</sup> and 26<sup>th</sup> pins (RC6 and RC7) acts as serial port. Here Asynchronous serial [5] communication is established between camera and microcontroller. When face found in cam frame, an active high signal is sent. It has 10 bit frame rate which includes start and stop bit along with 8 data bits. If face is not found, an active low signal is given to microcontroller. When active high signal is given to

microcontroller, the vehicle engine get starts and when active low signal is given to microcontroller, the vehicle engine get stop.

The temperature sensor (LM35) is an analog sensor. Hence the data line is given to ADC port of microcontroller. Port-A acts as ADC port. To make this, simple program is written. The data line of LM35 is given to PortA.0 (RA0). It gives single bit of data. And when temperature attains 40<sup>o</sup>c, the microcontroller identifies that the interior of vehicle is hot and start the cooling fan to maintain comfortable temperature inside the vehicle. The cooling fan is connected to Port D.5 (RD5) of the microcontroller. The cooling fan is switch on/off by relay through amplifier circuit. The microcontroller send an active high signal through RD5 and it is amplified by BC547 (An NPN transistor) and it energized the relay. The cooling fan is given to NO (Normally Open) armature of the relay. Hence the cooling fan gets ON and cools the interior of the vehicle.

The light sensor (LDR) is used to control the car head light system during the night time travel. The present system of car head light control (Dim & Dip) is manual operation. But the designed system control the car head lights to High beam (Dip) and low beam (Dim) as per the opposite vehicle light intensity. It makes the safe journey. During night time travel, if opposite vehicle light is on high beam and it directly falls on eye of the driver. Due to the reflection of light through front mirror, it is difficult to identify the road. So when opposite light falls on LDR, the car lights become low beam. Hence a clear vision appears which results to safe journey. LDR works on the principle of light. LDR acts as resistor based on intensity of light. If intensity of light is high, then the resistance is low and if intensity of light is less, then the resistance is high. Using this principle the LDR is given to port D.0 (RD0) through an op-amp. Here LM358 IC [3][4][5] is used which has dual op-amp. So that it gives high impedance signal which is fed to microcontroller. During high intensity of light, the LDR gives active high signal and microcontroller gives active high output to the Yellow LED's i.e Low beam lights [6] are ON. If no opposite vehicle and surroundings are dark, then the LDR gives active low signal and microcontroller gives active high signal to Blue LED's i.e High beam lights are ON. The Yellow LED's (Low Beam Lights) are connected to RD6 and Blue LED's (High Beam Lights) are connected to RD7.

## II. RELATED WORK

### 2.1 LDR SENSOR

An LDR is an input transducer (sensor) which converts brightness (light) to resistance. It is made from Cadmium Sulphide (CDS) and the resistance decreases as the brightness of light falling on the LDR increases. LDRs or Light Dependent Resistors are very useful especially in light/dark sensor circuits. Normally the resistance of an LDR is very high, sometimes as high as 1000 000 ohms, but when they are illuminated with light resistance drops dramatically. A multi meter can be used to find the resistance in darkness and bright light; these are the typical results for a standard LDR:

- **Darkness:** maximum resistance, about 1M $\Omega$ .

- **Very bright light:** minimum resistance, about 100 $\Omega$ .

For many years the standard LDR has been the ORP12, now the NORPS12, which is about 13mm diameter. Miniature LDRs are also available and their diameter is about 5mm. An LDR may be connected either way round and no special precautions are required when soldering. An LDR sensor with Op-Amp is interfaced with microcontroller to port D (PD0) and load is interfaced with microcontroller to the port C (PC0) using electromagnetic relays.

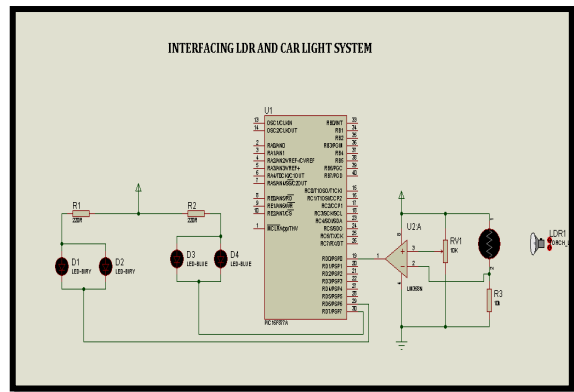

Fig.2.1 Interfacing LDR sensor to microcontroller

### 2.2 PIR SENSOR

PIR sensors are passive electronic devices which detect motion by sensing infrared fluctuations. Once a motion is detected, a high is sent to the signal pin. Because of the biological characteristic of organisms to emit heat, these sensors work well in detecting human motion and therefore are commonly implemented in security applications.

**A. Sensor Operation:** PIR sensors are composed of a solid-state piezoelectric chip. This chip is the heart of the device because it generates an electric charge when exposed to infrared radiation. This charge is then enhanced by an amplifier so the output voltage can be interfaced with other devices. The sensitivity of this device is enhanced by a translucent Fresnel lens covering this chip.

**B. Connecting a PIR sensor to an Arduino board:** Connecting a PIR sensor to an Arduino board is a simple process. PIR sensors consist of 3 pins, Vcc (Positive Voltage), Vss (Ground), and Signal. Interfacing it to the Arduino board requires Vcc to be connected to the +5, Vss to be connected to ground, and the Signal pin to be connected to any digital input pin. PIR sensors need approximately 10-60 seconds to calibrate. During this time it is important to make sure that there is no motion in the sensors' visual range.

### 2.3 PRECIPITATION (MOISTURE) SENSOR

The Moisture Sensor is used to measure the volumetric water content of environment. This makes it ideal for performing experiments in courses such as soil science, agricultural science, environmental science, horticulture, botany, and biology. Use the Moisture Sensor to:

- Measure the loss of moisture over time due to evaporation and plant uptake.

- Evaluate optimum soil moisture contents for various species of plants.
- Monitor soil moisture content to control irrigation in greenhouses.
- Enhance your Bottle Biology experiments.

### 2.4 TEMPERATURE SENSOR (LM35)

In this paper, in order to obtain the fan speed based on temperature, initially this temperature value has to be read and fed to the microcontroller. This temperature value has to be sensed. Thus a sensor has to be used and the sensor used in this paper is LM35. It converts temperature value into electrical signals.

LM35 series sensors are precision integrated-circuit temperature sensors whose output voltage is linearly proportional to the Celsius temperature. The LM35 requires no external calibration since it is internally calibrated. The LM35 does not require any external calibration or trimming to provide typical accuracies of  $\pm 1/4^\circ\text{C}$  at room temperature and  $\pm 3/4^\circ\text{C}$  over a full  $-55$  to  $+150^\circ\text{C}$  temperature range.

## III. IMPLEMENTATION ARCHITECTURE

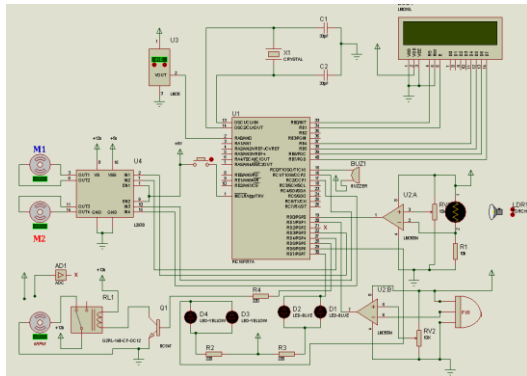

Fig.3.1 Interfacing Diagram Of Implementation

## IV. RESULT AND EXPERIMENTAL TOOLS

### A. Hardware Requirements

- PIC microcontroller of type 16F877A is electronic circuits that can be programmed to carry out a vast range of tasks. They can be programmed to be timers or to control a production line and much more.
- LDR (light dependent resistor) sensor is used to detect the intensity of light. As the intensity of light increases, the resistance decreases.
- Temperature sensor (LM35) type of temperature sensor is used to detect change in environmental or interior temperature. Precipitation sensor works by absorbing water content in the environmental conditions.
- MAX232 that converts signals from an RS-232 serial port to signals suitable for use in TTL compatible digital logic circuits. LCD HD44780 is a liquid crystal display consists of liquid crystals between electrodes.
- DC Motor 100RPM which represents the vehicle. Relay SPDT to control DC motor to on and off.

### B. Software Requirements

- **MP LAB-XC:** It is a compiler tool provides the platform for writing, editing, execution and compilation of program. The program used in the

paper is embedded 'c'. The compiler generates .hex file which is burn onto chip.

- **PROGRAM BURNER:** UC flash burner is used as a tool to burn or write the program onto the chip. It is an external hardware tool with 40 pin socket.
- **MATLAB:** It is a high-level language and interactive environment for numerical computation, visualization, and programming. Using MATLAB, we can analyze data, develop algorithms, and create models and applications.
- **PROTEUS7.0:** It is a digital simulation and circuit design tool. It provides the platform for PCB layout, circuit design and real time digital simulation.

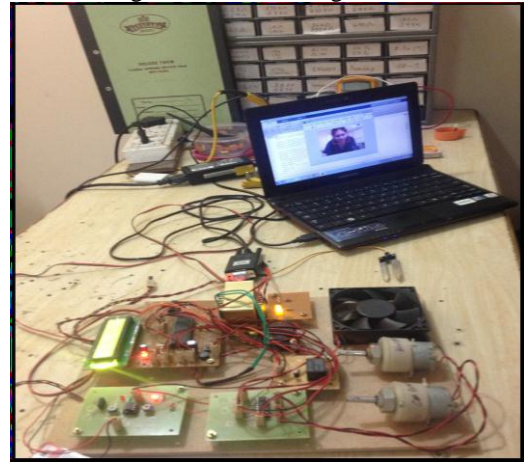

The Picture shows that MATLAB interface with web camera and microcontroller through serial port. The Face has been recognized with-in the limited frame. When face found MATLAB authenticate the face and shows OK FACE FOUND and send '1' digital signal to microcontroller to start the car engine motor.

## V. CONCLUSION

It can be summarized that this module, although only a prototype, is completely functional device that performs its function safely, reliably and efficiently. Possibility of application is not limited only to the vehicle ventilation. The module is extremely expandable in both ways: it is upgradeable for new tasks as well as compatible for integration into some existing systems. Nearly every component can be used for several other functions, which can be achieved only by software upgrade. Upgrading hardware opens even greater possibility to upgrade the software and there are countless capabilities. Despite all the positive sides of this module, the question remains whether it can find its application in the market. Since the module is impracticable as a physical unit (because of peripheral unit), it is necessary to adapt it to any individual vehicle. Thus its individual installation is not cost-effective. It could find its purpose and economic efficiency if it would be serially mounted in same type of vehicle. The paper is implemented with simple devices to drive more comfortably in different environmental conditions. The paper is designed with some limitations. The GSM modem can be used for security levels. Also it can be implement to use GPS system to know the position of car when theft or got accident. It can also implement to operate the engine vehicle based driver alcohol content.

## REFERENCES

- [1] Leo Budin, Microcomputers and microcontrollers, Element, 2004.
- [2] Slobodan Ribaric, Advanced microprocessor architectures, Element, 1999, IEEE Trans. Computers, vol. 52, no. 5, pp. 545-557, May 2003.
- [3] Antun Sarcevic, Electronic components and analog circuits, Technical school of Ruder Boskovic, 1996.
- [4] Aleksandar Szabo, Impulse and digital electronics – part 1, Technical school of Ruder Boskovic, 2000.
- [5] Boris Raic, Module for automatic raising and lowering car windows, unpublished EEE TRANSACTIONS ON Information and Communication Technology, (MIPRO) 26-30, May 2014.
- [6] Guangzhou Besyo auto parts Co, Ltd., BY-R606N, brochure.

## BIOGRAPHIES



**PATCHVA.V.S.USHA,** Graduated (B.Tech) in Electronics and Communication Engineering from Jawaharlal Nehru Technological university and currently pursuing M.Tech in Electronics and Communication Engineering from Jawaharlal Nehru Technological University, Hyderabad, India. Interested in working on Wireless Networks and power communication domains.



**S. RAJ KUMAR,** Post Graduated in Electronics and Communication Engineering (M.Tech) From JNTU, Hyderabad and Graduated in Electronics and Communications Engineering (B.Tech) from JNTUH. He is working as Assistant Professor in Department of Electronics and Communications Engineering in Mallareddy Engineering College for women, R.R Dist, AP, India. His Research Interests in Embedded systems and VLSI.