

PROGRAMMABLE LOGIC CONTROLLER AND μ C 8051 BASED AUTOMATIC IRRIGATION SYSTEM WITH WIRELESS CONTROL

Gunjan Lanje¹, Sankalp Sarve², Diwakar Korsane³, Abhay Halmare⁴, Dr. G.H. Agrawal⁵

Student, Department of Electrical Engineering, K.D.K. College of Engineering, Nagpur, India ^{1,2}

Assistant Professor, Department of Electrical Engineering, K.D.K. College of Engineering, Nagpur, India ^{3,4}

Professor, Department of Electrical Engineering, K.D.K. College of Engineering, Nagpur, India ⁵

Abstract: Nowadays with increased population in world, necessities of increased productivity of land, with the use of minimum water and electricity and use of recent technologies, has been increasing day by day. This paper aims at study and demonstration of how soil humidity based irrigation of land helps to fulfill above necessities. Implementation of humidity sensor, adjustable speed drives and information and communication technology (ICT) provides many advantages from various points of view. In Vidharbha region of Maharashtra, percentage irrigation is less and whatever is present are all of traditional type; in which excessive use of water and electricity are the main drawbacks. The use of PLC and μ C along with various sensors can prove a milestone in increasing the productivity of land, reducing water use thus reducing soil infertility, reducing use of electricity and making the irrigation system smart and user friendly, with considerable reduction in labor work and time of farmers. This paper discusses various features and technologies of automation in farming that can be integrated with ICT devices. This paper explains the importance of use of ASD for motor and wireless control of system, which proves important step towards smart India- smart Indians.

Keywords: Adjustable Speed Drives, Microcontroller, Programmable Logic Controllers, Supervisory Control and Data Acquisition

I. INTRODUCTION

In an irrigation system, the watering to land is done with the help of sprinklers which are either drip or rotor or spray sprinklers. The concept behind use of sprinklers is to minimize the use of water and labor work of farmer. But still, this system of watering the land is not that much efficient. This system can be made more efficient with the use of automation technologies and ICT.

Compared with traditional irrigation system, the proposed system overcomes the loss due to excessive use of electricity and water and reduces the human efforts, with the help of interfaced humidity sensors, LCD and wireless communication technology; ensuring equivalent water supply over an area and saving of electricity and water. The variable speed drive using PLC is the key sub-system for pressure management. The proposed concept is described and supported by a demonstrating prototype model and experimental validation demonstrates the proposed automation system. The experimental validation of Automatic Irrigation System using PLC and μ C 8051 is done based on different parameters such as moisture of soil, availability of water reserves, status of solenoid valves, and also the results are compared with a traditional irrigation system.

II. NECESSITY OF AUTOMATION IN AGRICULTURE

An Agriculture has a vital role in our economy. About 40 to 50 percent of population depends on agriculture and its related fields for their survivor. The available management is not sufficient to that of requirement. In traditional

irrigation system, there is wastage of water, electricity and excessive watering of plant leads to soil erosion. Different region of land may have different type of soil which requires watering for different time period. But in traditional system this is not taken into consideration. Also man power required is more. The process requires time to time human analysis and operation management by humans. Thus we have developed the automated system that will manage humidity of soil, controls the water spray over an area of soil based upon humidity and accordingly controls the water supply by pump by adjusting the output of pump, thus saving electricity.

III. SYSTEM DESIGN

For explaining our automatic irrigation system, we have design a prototype model for demonstration purpose. For controlling water spray over an area, as an input, we have interfaced humidity sensor. And for controlling water pumped by motor, we have interfaced solenoid valve. According to humidity, water spray will be made on and off with the help of solenoid valve. And according to number of valves opened and closed, pumped water has to be controlled by controlling speed of motor using ASD or VFD.

For demonstration purpose, we have used 2 valves and two sensors. Thus two sprinklers are to be controlled. The model is 3 feet by 6 feet. Each sprinklers give a spray in circle of radius 1.5 feet, thus two sprinklers are 3 feet apart. The height of sprinklers from ground surface is 1.5 feet. Two types of soil are covered by spray of two sprinklers. As two different soils will take different time to

get 100% humid, so different time for which valve will be open and accordingly motor speed needs to be regulated.

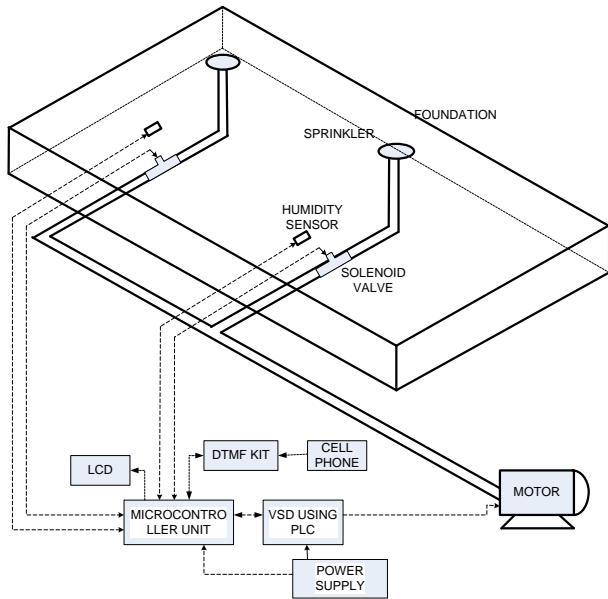

Fig. 1 Demonstration Prototype Layout

IV. IMPLEMENTATION OF SYSTEM

The layout of system is as shown in fig.1. Description of various components used is as follows.

(a) *Motor Pump-*

The motor pump used is a single phase induction motor having specifications- 230 V, 50 Hz, 1500 RPM, 40 Watt. The motor is so selected considering the number of sprinklers and the area to be covered by them.

(b) *Solenoid Valve-*

The solenoid valves used here are 12 volt DC operated. The power supply and control signals to valves are given through μC 8051. The valves are normally closed type i.e. when no signals are given by μC then valve will remain off and hence the sprinkler.

(c) *Humidity Sensor-*

The humidity sensor is a device which senses the humidity content of soil and gives voltage output in proportion to moisture content of soil. The voltage output is analog and hence need to be converted to digital to be fed as input to μC .

(d) *Sprinklers-*

The sprinklers are spray type. They can withstand a pressure for spray upto 12 feet radius circle. The height of sprinkler installation is so determined that spray will be of 1.5 feet radius and also motor is selected accordingly.

(e) *μC 8051-*

This is the main controller in this system. The humidity sensor, solenoid valves, LCD display all these important devices are controlled by this controller. The LCD will display the status of solenoid valves and the humidity sensor. It will display whether the valve is open or closed and also the moisture content of soil in numerical form.

(f) *PLC-*

The programmable logic controller used here is Allen Bradley Micrologix-1400. It is the key element in this system for controlling water pressure by controlling motor speed. The controller is used for developing PWM pulses to be fed to transistor thus giving input to motor performing as a variable speed drive or adjustable (VSD) speed drive (ASD).

(g) *Power Supply-*

The supply is DC to microcontroller and AC to PLC. Microcontroller unit requires DC 12 Volt supply where as PLC requires AC 230 volt supply.

V. WHY BOTH PLC AND μC ?

PLCs are good (Fast operation of switching) at turning outputs ON or OFF based on the state of inputs (control). This property is useful for VSD; as compared to μC .

PLCs are more rugged than computers and typically last many years without needing replacement.

But

- i. PLCs are not the best at reading and writing databases,
- ii. they are not the best at generating reports,
- iii. PLCs are not the best at displaying data and information to the operator &
- iv. Do not perform well when handling large amounts of data or complex data.
- v. Also, mobile communication is not possible, in some PLC's.

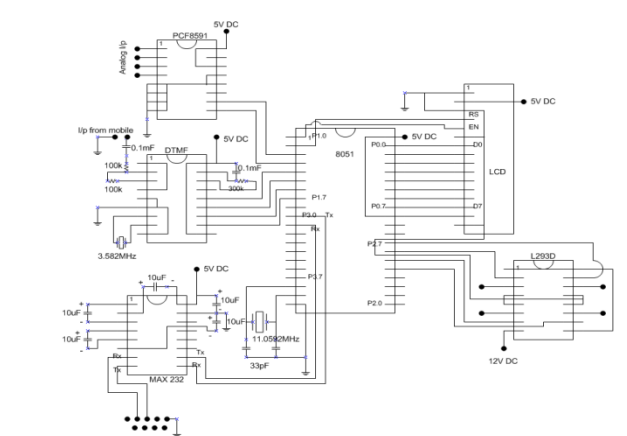

Fig. 2 Circuit Diagram for μC unit and components

VI. PROCESS CONTROL

In this system the main controller unit is μC and the PLC is supporting controller which only controls the motor speed and thus pressure management of water pumped by motor.

Control engineering has evolved over a time. In the past humans were the main methods for controlling a system. More recently electricity has been used for control and early electrical control was based on relays. These relays allow power to be switched on and off without a mechanical switch. It is common to use relays to make simple logical control decisions. The development of low cost computers has brought the most recent revolution, PLC and μC . Both of them have their own advantages and disadvantages, as discussed in previous section.

The μC here takes input from sensor and gives the controlling signals to devices.

The output of humidity sensor, being analog, needs to be converted to digital form. This function is performed by ADC IC called PCF 8591. This IC can perform both action ADC and DAC, so needs to be programmed its control word register using μC for proper selection of function.

The program is so designed that if the humidity sensor gives the signal of 100% humidity, the solenoid valve in that particular area is made off. Again when the humidity falls below the prescribed value, the μC will switch on the solenoid valve, thus starting water supply.

The solenoid valve is a high current requirement device. So, in order to operate them, a control signal is sent to L293D IC which gives 1 Amp current output. This current is used to operate relays, which in turn operate solenoid valve, supplying high current to it directly from power supply (DC).

Now, suppose that, there are two types of soil. So the time to make those soils completely humid will be different. Depending upon that, solenoid valves will remain on for different time periods. Thus both solenoid valves may or may not be on simultaneously. When both are on, the motor should operate at its full speed. But when one is on and other is off, then the motor needs to be operated at half the speed. This action of controlling speed is performed by PLC based ASD or VSD.

In this demonstrating project, we have programmed the ASD for two speeds only. But practically, considering the number of valves, and water pressure requirement for open valves, the PLC can be programmed accordingly and speeds can be controlled.

In this manner, the complete closed loop system will work.

VII. WIRELESS CONTROL OF SYSTEM

It is commonly seen that the farmer used to go to farm and switch on and off the power supply. When the power is cut the system gets off, but after again the supply comes, there is a device in market, which will automatically start the system. But still, farmers decide when to start, for how many hours to remain on and when to off the system. This takes lots of time and labour of farmers.

The proposed system is so designed to give remote access to system. We have used DTMF i.e. Dual Toned

Mobile frequency technology. Using this, the farmer can switch on and off the system from anywhere by making a simple call and pressing a single key. When we make a call, call is accepted, when key is pressed, the sound is heard by both caller and receiver. This is DTMF, and each key has a fixed frequency. The IC CM8870 converts that frequency into digital 4 bit output. This four bit output can be used as signal to switch system on and off. μC uses that signal and as per program make the complete system on or off, by giving control signals to PLC and other interfaced devices. We have programmed the μC such that if the caller press key 1 then system will be switched on and if key 2 the switched off. It is to be noted here that the cell phone will be needed connected to μC and the phone should possess auto call receive facility.

VIII. VISUAL DISPLAY TO FARMER

The LCD is interfaced to μC . The controller is so programmed to display which solenoid valve is open and which is closed. Also it will display the soil moisture content in numerical form. The output analog voltage of humidity sensor is converted to digital binary bits which are calibrated to give output on LCD screen in % of moisture in soil. The figure 2 shows the interfacing of different devices and IC's to μC .

IX. CONCLUSION

This paper reviews the important aspect of the demonstration project model on automated irrigation system using PLC and μC , with wireless control. The results are obtained as follows by performing a demo cycle of some particular time period.

The wireless control of system helps farmer to save his time and efforts as it gives him remote access to system. The closed loop control of system makes the system automatic. Use of humidity sensor helps to reduce the water wastage and thus prevent from excessive irrigation of land and thus prevents infertility of soil. The ASD input to motor helps to reduce losses and improve efficiency of motor. The pressure management helps to increase the life of PVC pipes and other material components. The overall productivity can be improved using the system. It will reduce the expenditure on electricity bill and saves water. Also helps to reduce human efforts.

REFERENCES

- [1] Gary Dunning; "Introduction to PROGRAMMABLE LOGIC CONTROLLERS", 3rd Edition, Cengage Learning, New Delhi, 2006.
- [2] Allen Bradley; "Micrologix 1200 and Micrologix 1400 Programmable Controllers (Bulletines 1762 and 1764)", Instruction Manual, Rockwell Automations.
- [3] Mohammad Mazidi; "The 8051 Microcontroller and Embedded System, using Assembly and C", 2nd Edition, Pearson Publication, Eleventh Impression, 2012.
- [4] Mostefa M. Ghassoul M.I.E.E.E.; "Automatic Irrigation System Using PLC," Dammam Technical College, BP 7650, Dammam 31472.
- [5] Deepak Kumar Roy; Murtaza H. Ansari; "Smart irrigation Control System", International Journal of Environmental Research and Development (IJERD), 2014, ISSN 2249-3131, Volume No.4, pp. 371-374.
- [6] Datasheets of microcontroller IC 8051; DTMF IC CM8870; ADC IC PCF8591; IC L293D; MAX232.