

Simulation and Analysis of Brushless DC Motor Based on Sinusoidal PWM Control

Jainesh M. Patel¹, Hitesh V. Hirvaniya², Mulav Rathod³

M.Tech Scholar, Electrical Engineering Department, UVPCE, GANPAT UNIVERSITY, Kherva (Gujarat), India¹

Assistant Professor, Electrical Engineering Department, UVPCE, GANPAT UNIVERSITY, Kherva (Gujarat), India²

Assistant Professor, Electrical Engineering Department, SVIT (GTU), Vasad (Gujarat), India³

Abstract: This Paper is Presented According to the Control Strategy of the Pulse Width Modulation Techniques. Sinusoidal Pulse Width Modulation (SPWM) is used for Simulation of Brushless DC Motor Drive. Also the Hall Sensors are used to Sense the Rotor Position. According to the Hall Signal of Sense from the Rotor we get Six Signals. By Comparing Reference Speed and Actual Speed we get Error signal, now this Error Signal is compared with the Triangle Wave Generator and finally we get Final Error Signal. By Adding Previous Six Signals with this Error Signal of output will get Six Pulse, the Generated Six Gate Pulse given into the Inverter Circuit. The Simulation software used for the same is MATLAB/SIMULINK.

Keywords: Brushless DC Motor, Sinusoidal Pulse Width Modulation (SPWM), Simulation using MATLAB Simulink

I. INTRODUCTION

Brushless DC Motor Drive is introduced in the decade of 1990's. The research is still going the low cost and improved efficiency of Brushless DC Motor Drive. In recent years, as permanent magnet materials, computer technology, intelligent control technology and power electronics technology, especially the power switch component technology has been rapid development, and it laid an important foundation for the research and manufacture of the permanent magnet brushless.

DC motor (BLDCM) BLDC motor is becoming more popular and is widely used in wide range of applications from small, low power applications like fan and disk drives to the large industrial automation and aerospace applications because of its advantages such as better speed vs. torque characteristics, high efficiency, low noise, long operating life and high power density [3].

BLDC motors are powered by a conventional 3Ø inverter which is controlled based on the rotor position information so it requires rotor position information for electronic commutation. Position sensors such as Hall sensor, position resolver and absolute position sensors are used to detect rotor position. Generally hall sensors are used to detect position of rotor [9].

II. BASIC CONCEPT OF BLDC MOTOR DRIVE

A. Block Diagram of BLDC Motor Drive

The given block diagram in Figure-1 is introduce the drive system of electric motor weather it is AC/DC. Motor drive which is used for BLDC Motor is based on Pulse Width Modulation (PWM).

In given block diagram the control unit is generating gate pulse according to the reference and feedback signal and control the speed of motor.

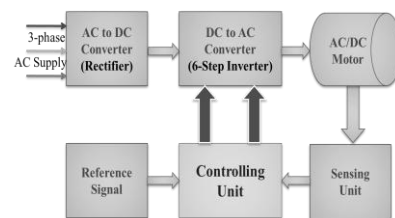

Figure 1 Basic Block Diagram of BLDC Motor Drive

B. Hall Sensor Output Pattern

Table 1 Switching sequences according to the hall pattern

Mode	Hall Sensor Output			Inverter Switches						Phase Voltage		
	H3	H2	H1	S6	S4	S2	S5	S3	S1	Va	Vb	Vc
1	1	0	1	0	1	0	0	0	1	Vdc/2	Vdc/2	-
2	1	0	0	0	1	0	1	0	0	-	Vdc/2	Vdc/2
3	1	1	0	0	0	1	1	0	0	Vdc/2	-	Vdc/2
4	0	1	0	0	0	1	0	1	0	Vdc/2	Vdc/2	-
5	0	1	1	1	0	0	0	1	0	-	Vdc/2	Vdc/2
6	0	0	1	1	0	0	0	0	1	Vdc/2	-	Vdc/2

The switching pattern of inverter as per the rotor position. And also it mentioned the phase voltage of each winding. The switching pattern according to the Hall sensor signal given into the Table-1.

C. Ideal Wave Form of BLDC Motor

The ideal wave form of the BLDC Motor is given in the Figure-2. We can see the back EMF of the motor as well as the individual phase current of the motors.

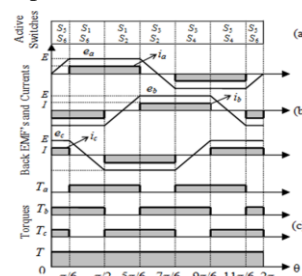

Figure 2 Ideal Wave Form of BLDC Motor Drive

III. SINUSOIDAL- PULSE WIDTH MODULATION TECHNIQUES

In Sinusoidal Pulse Width Modulation (SPWM) technique the signal is generated by comparing a sinusoidal reference signal with a triangular carrier wave of frequency f_c . The frequency of the reference signal f_r determines the output frequency f_o and its peak amplitude A_r controls the modulation index M . The gating signal for SPWM technique is shown in Figure-3.

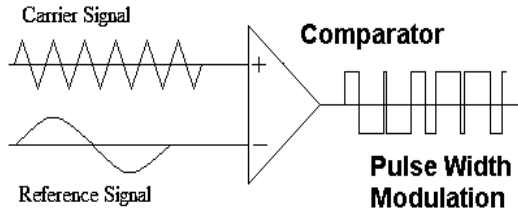

Figure 3 Principle of PWM Generation

Now comparing the bipolar carrier signal V_{cr} with two sinusoidal reference signal V_r and $-V_r$ produces gating signal g_1 and g_4 respectively. However g_1 and g_4 cannot be released at the same time. The number of pulses per half cycle depends on carrier frequency. Within the gate signal

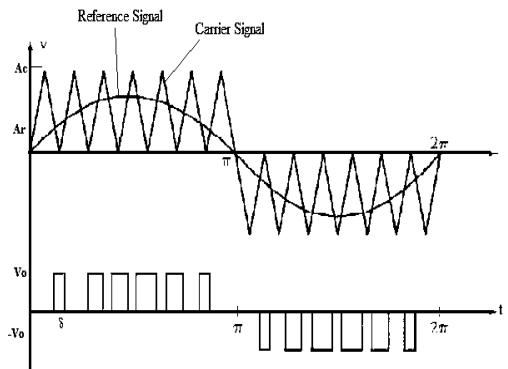

Figure 4 Sinusoidal PWM Techniques

Generated from H-bridge, the two transistor of the same arm cannot conduct at the same time. The instant is shown in Figure-4.

IV. SIMULATION OF BLDC MOTOR DRIVE USING CONTROL SCHEME

The operation of Brushless DC Motor Drive using PWM is given into the Figure-5. The control strategy is used for the following drive system is Sinusoidal Pulse Width Modulation (SPWM). Also we used three Hall Sensors for calculation the Back EMF of the motor. Hall sensor signals sense the rotor position and according that signal we can calculate the Back EMF of the motor. Once Back EMF signal is achieved then that signal is compared with the carrier wave triangle signal and we can get Six Pulse gate signal pattern from that. Finally the achieved gate pulse is given into the Inverter Bridge and we get the speed control of the Brushless DC Motor.

A. Simulation of BLDC Motor

Simulation of the Brushless DC Motor is given into the Figure-6. As we talked earlier about the Hall Sensor

Signals and the Back EMF calculation according to the hall signals and then finally Six Pulse achieved by doing all the exercise we can get the smooth speed control of the Brushless DC Motor.

B. Results

According to the simulation of Brushless DC Motor we can get the result in below (a) Three Phase Back EMF is given in Figure-7, (b) Three Phase Hall Effect Signal is given in Figure-8, (c) Three Phase Stator Current is given in Figure-9, (d) Electromagnetic Torque is given in Figure-10.

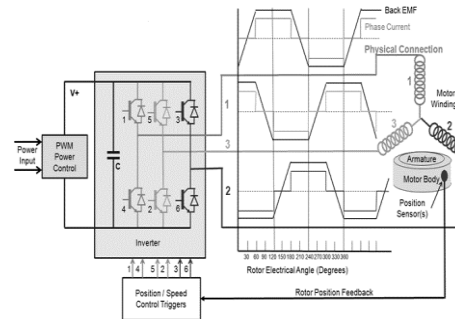

Figure 5. BLDC Motor Control Using PWM

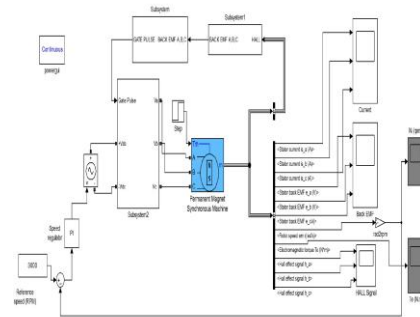

Figure 6 Simulation Circuit using MATLAB/SIMULINK

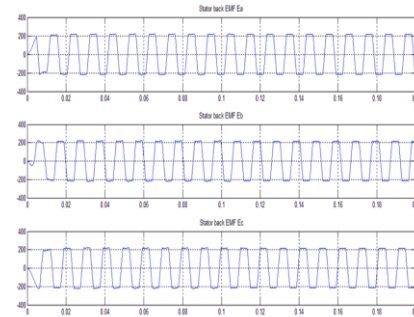

Figure 7 Three Phase Back EMF of BLDC motor

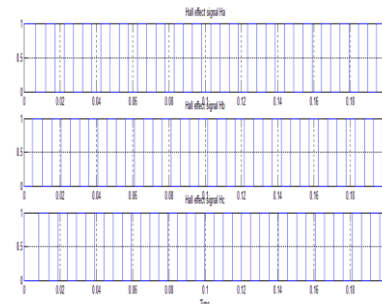

Figure 8 Three Phase HALL Effect Signal

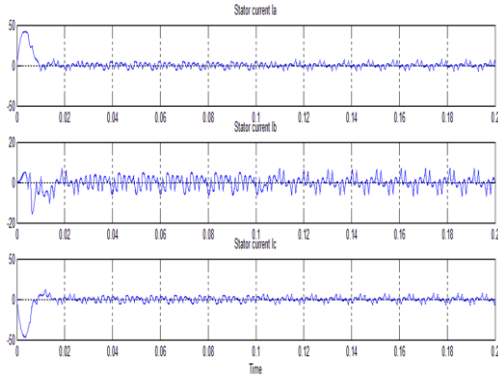

Figure 9 Three Phase Stator Current

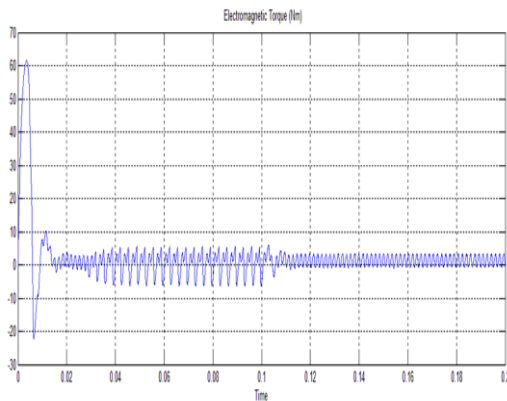

Figure 10 Electromagnetic Torque in Nm

V. CONCLUSION

The applications of brushless DC (BLDC) motors and drives have developed significantly in recent decade in the domestic as well as industrial appliances and automotive industry. The predictable sensorless method based on neutral motor point has limited its application since it has relative speed range, suffering from high common mode voltage noise and high frequency switching noise. In this paper, a back EMF sensing techniques, direct back EMF sensing, without motor neutral voltage for BLDC drives in proposed, analysed, and extended, overcoming the drawbacks of the conventional scheme.

The harmonizing PWM algorithm can eradicate the offset voltage in the back EMF signal caused by the voltage drop of the diode, and also increase the system efficiency by reducing the conduction loss. The SPWM is quite pretentious and simplicity to control the BLDC motor drive.

ACKNOWLEDGMENT

I would like to articulate my profound gratitude and indebtedness to Prof. Hitesh V. Hirvaniya, who has always been a source of motivation and guiding factor throughout the dissertation. It has been a great pleasure for me to get an opportunity to work under him.

I would like to thank Dr. S. N. Pandya (Associate Professor at L.D. College of Engineering) for taken Expert Lecture on A.E.M., Prof. V. B. Patel (Assistant Professor at GANPAT University), Prof. A. N. Patel (Assistant Professor at NIRMA University Ahmedabad), for them valuable teaching is useful to do my work in flexible way.

REFERENCES

- [1] Dae-Kyong Kim, Kwang-Woon Lee "Commutation Torque Ripple Reduction in a Position Sensorless Brushless DC Motor Drive" IEEE Transaction Power Electronics, vol. 21, no. 6, November 2006.
- [2] Yong Liu, Z. Q. Zhu, and David Howe "Direct torque Control of Brushless DC Drives With Reduced Torque Ripple" IEEE Transaction On Industrial Applications, vol. 41, no. 2, March/April 2005.
- [3] Namhun Kim, Hamid A. Toliyat, Issa M. Panahi, and Min-Huei Kim "BLDC Motor Control Algorithm for Low-Cost Industrial Applications" IEEE 1-4244-0714-1/07 2007.
- [4] Jianfei Yang, Yuwen Hu, Wenxin Huang, Jianbo Chu, Jin Gao "Direct Torque Control of Brushless DC Motor without Flux Linkage Observation" IEEE 978-1-4244-3557-9/09 2009.
- [5] Fang Lin Luo and Hock Guan Yea "Advanced PM Brushless DC Motor Control & System for Electric Vehicles" IEEE 0-7803-6401-5/00 2000.
- [6] Carsten-Sunke Berendsen, Gerard Champenois, and Alain Bolopion "Commutation Strategies for Brushless DC Motors: Influence on Instant Torque" IEEE Transaction on Power Electronics, vol. 8, no. 2 April 1993.
- [7] M. Nasir Uddin, Tawfik S. Radwan, and M. Azizur Rahman "Fuzzy-Logic-Controller-Based Cost-Effective Four-Switch Three-Phase Inverter-Fed IPM Synchronous Motor Drive System" IEEE Transaction on Industrial Applications, vol. 42, no. 1, January/February 2006.
- [8] Anand Sathyan, Nikola Milivojevic, Young-Joo Lee, Mahesh Krishnamurthy, Member, and Ali Emadi "An FPGA-Based Novel Digital PWM Control Scheme for BLDC Motor Drives" IEEE Transaction on Industrial Applications, vol. 56, no. 8, August 2009.
- [9] Vinatha U, Swetha Pola, Dr.K.P.Vittal "Recent Developments in Control Schemes of BLDG Motors" IEEE 1-4244-0726-5/06 2006.
- [10] Byoung-Hee Kang, Choel-Ju Kim, Hyung-Su Mok, Gyu-Ha Choe "Analysis of Torque Ripple in BLDC Motor with Commutation Time" IEEE 0-7803-7090-2/01 2001.
- [11] Hamdy Mohamed Soliman1, & S. M. Hakim "Torque Ripple Minimization, Suppress Harmonic, and Noise of Brushless PM Synchronous Motor Derived by Field Oriented Control", IJRAS 12(3) September 2003.
- [12] Satoshi Ogasawara and Hirofumi Altagi "An Approach to Position Sensorless Drive for Brushless DC Motors", IEEE 90/CH 2935-5/90/0000-0443 1990

BIOGRAPHY



Jainesh Patel received the Diploma in Electrical Engineering from Technical Education Board, Gujarat, India, in 2006 and B.Tech in Electrical Engineering from Nirma University, Gujarat, India, in 2012. Currently He is Pursuing 4th Sem of M.Tech (Specialization in Electrical Engineering) from GANPAT UNIVERSITY. After completion of D.E.E., Since 2006 He has been worked for two and half year in SAC (ISRO), Ahmedabad (Gujarat), India. Also he has been worked for a two year in Institute For Plasma Research (IPR), Gandhinagar (Gujarat), India.