

# Design the 2×100 gbps based hybrid WDM optical network

HimaniRathore<sup>1</sup>, Ankita R. Mowar<sup>2</sup>, Dr.SoniChanglani<sup>3</sup>

M.Tech Scholar, ECE Department, LNCTS, Bhopal MP, India<sup>1</sup>

A.P., ECE Department, LNCTS, Bhopal MP, India<sup>2</sup>

HOD, ECE Department, LNCTS, Bhopal MP, India<sup>3</sup>

**Abstract:** Multiplexing is an essential part in a communication system. It is widely employed due to increase transmission capacity and to reduce system costs. There are three basic types of multiplexing technique in communication systems; time division multiplexing (TDM), frequency or wavelength division multiplexing (FDM) or (WDM), and code division multiplexing (CDM). In this paper, wavelength division multiplexed optical communication system is designed based on different duty cycle. The design is proposed for 10- users and data rate is 2×100 transmitted up to 78 km using SSMF.

**Keywords:** WDM, BER

## I. INTRODUCTION

Multiplexing is the key issue to increase the capacity of communication systems. It allows different users to share the available carrier bandwidth and communicate simultaneously. The goals of all multiplexing techniques are to support as many users at as high speed and at the lowest cost as possible. In existing systems, the medium is normally shared based on time slot (TDM), carrier frequency (FDM/WDM) or spectrum coding (CDM) [2]. TDM is the most widely used multiplexing technique in communication systems today. However, for multiplexing high number of users with high data rates, high speed multiplexer and de-multiplexer are required, resulting in very high cost for TDM systems. At higher speeds clock recovery is another essential issue that may render the system highly complicated and costly for TDM systems. Therefore, many investigations have been done to design and develop reliable and cost-effective clock recovery modules for TDM in both the electrical and optical (thus, OTDM) versions [4]. A requirement for higher transmission capacity has drawn the attention of researchers worldwide to develop new modulation formats, multiplexing techniques and detection systems. This paper proposes a near futuristic approach for better utilization of the transmission capacity of optical fibers. A new multiplexing technique based on duty cycle division is proposed, thus the name Duty Cycle Division Multiplexing (DCDM). DCDM can be applied in both electrical and optical domains, for wired and wireless systems. This technique allows for more efficient use of time slots as well as the spectrum, taking advantage of both the conventional TDM and FDM. Here we have designed a 2×100 Gbps based hybrid WDM network.

## II. SIMULATION SETUP

Figure-1 shows the simulation setup of 2×100 Gbps DCDM based Optical Communication System. The data of each user is transmitted with a bit rate of 20 Gbps, that generated by RZ pulse generator with different duty

cycle. The RZ-PG1 modulates 15%, RZ-PG2 modulates 30%, RZ-PG3 modulates 45%, RZ-PG4 modulates 60%, and RZ-PG5 modulates 75%. The last 25% is used for guard band purpose, to avoid symbol overlapping in communication system. The output of RZ pulse generators are electrically multiplexed using Electrical adder. The Output of electrical adder is the electrical multiplexed signal of all users; the multiplexed data is converted in optical signal by modulating the continuous wave (CW) laser.

The operating wavelengths of Laser-1 and Laser-2 are 1550 nm and 1552 nm respectively. These wavelengths are multiplexed (i.e.WDM) and sent down through an optical fiber cable of 100 km. The received optical signal is de-multiplexed and amplified by optical amplifiers. Then these signals are detected by PIN detectors which perform optical to electrical conversion.

Table 1: Setup parameter for 10-user hybrid WDM system

S.N.	Setup parameter	
1	No. of bit sequence generator	10
2	Pulse Generator	RZ
3	Bit rate, Gbps	100
4	Operating wavelength (nm)	1550 & 1552
5	Launched power mw	2
6	Distance , km	100
7	Optical amplifier , Gain (dB)	20
8	Photo detector PIN	2

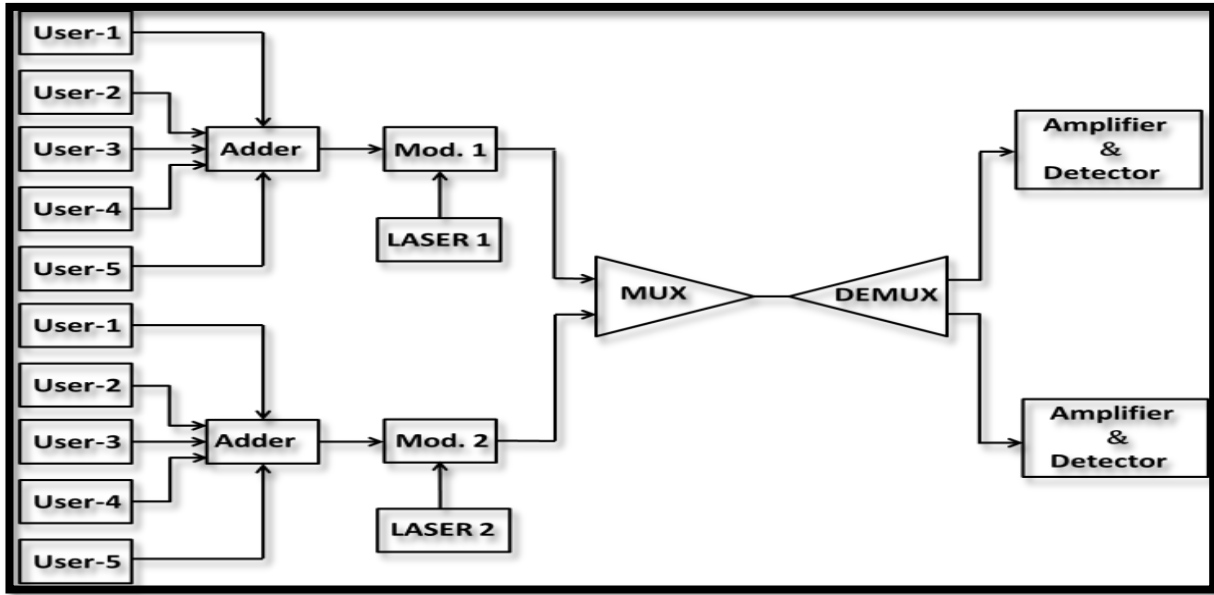

Figure1. Simulation setup of  $2 \times 100$ Gbps based hybrid WDM network

### III.RESULT

Figure-2 shows the graph of received BER versus length for  $2 \times 100$ Gbps based hybrid WDM network, the multiplexed signal is transmitted up to 100 km using standard single mode fiber. The received signal is analysed in term of Bit Error Rate (i.e. BER) and signal maintain its minimum BER  $10^{-9}$  up to 78 km.

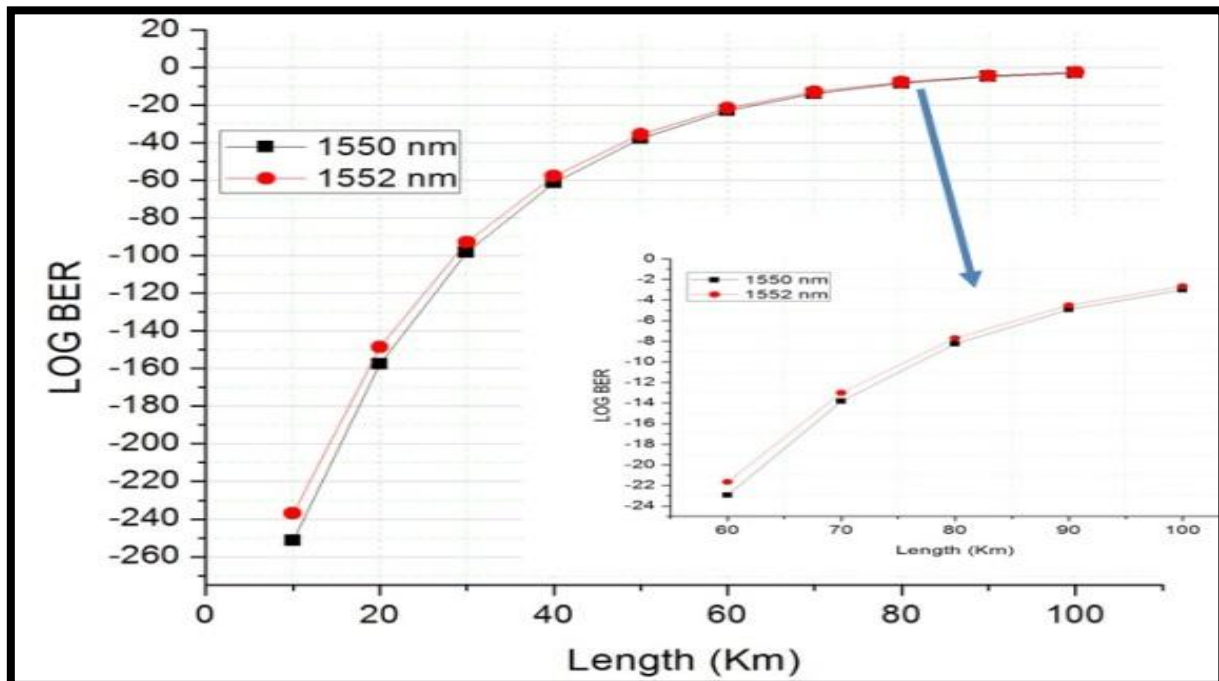

Figure-2: BER v/s Length

#### IV. CONCLUSION

The 2×100 Gbps Based Hybrid WDM Optical Network is successfully designed. A technique of BER estimation for 10 users WDM based optical communication network shows that signal is transmitted up to 78 km using SSMF.

#### REFERENCES

- [1] Avinash Singh, Gireesh G. Soni, Abhishek Tripathi and Anurag Shrivastava “*Design of 3×60 Gbps DCDM based WDM system*” 2012 International Conference on Optical Engineering (ICOE) in IEEE 2012.
- [2] M. K. Abdullah, G. A. Mahdiraji, A. M. Mohammadi, M. Mokhtar and A. F. Abas “*Duty Cycle Division Multiplexing (DCDM), A New Electrical Multiplexing Technique for High Speed Optical Communication Systems*”, Proceedings of IEEE 2008 6th National Conference on Telecommunication Technologies and IEEE 2008, 2nd Malaysia Conference on Photonics, 26-27 August 2008, Putrajaya, Malaysia.
- [3] O. Ozolin and G. Ivanovs “*Realization of optimal FBG Band-Pass Filters for High Speed DWDM*” Journal of Electronics and Electrical Engineering, 2009.
- [4] J. H. Lee, S. Ohara, T. Nagashima, T. Hasegawa, N. Sugimoto, K. Igarashi, K. Katoh, and K. Kikuchi, “*Clock recovery and demultiplexing of high-speed OTDM signal through combined use of bismuth oxide nonlinear fiber and erbium-doped bismuth oxide fiber*,” IEEE Photonics Technology Letters, vol. 17, no. 12, pp. 2658-2660, Dec. 2005.
- [5] Jyotsna Rani Mahapatra, Manisha Chattopadhyay “*Spectral characteristic of UNIFORM FIBER BRAGG GRATING using couple mode theory*” International Journal of Electrical, Electronics and Data Communication, Volume-1, July-2013.